



# **i960<sup>®</sup> CA/CF Microprocessor User's Manual**

**March 1994**

Order Number: 270710-003



Intel Corporation makes no warranty for the use of its products and assumes no responsibility for any errors which may appear in this document nor does it make a commitment to update the information contained herein.

Intel retains the right to make changes to these specifications at any time, without notice.

Contact your local Intel sales office or your distributor to obtain the latest specifications before placing your product order.

MDS is an ordering code only and is not used as a product name or trademark of Intel Corporation.

Intel Corporation and Intel's FASTPATH are not affiliated with Kinetics, a division of Excelan, Inc. or its FASTPATH trademark or products.

\*Other brands and names are the property of their respective owners.

Additional copies of this document or other Intel literature may be obtained from:

Intel Corporation  
Literature Sales  
P.O. Box 7641  
Mt. Prospect, IL 60056-7641  
or call 1-800-879-4683

© INTEL CORPORATION 1994

**CHAPTER 1**

**INTRODUCTION**

|       |  |     |
|-------|--|-----|
| 1.1   | i960 <sup>®</sup> MICROPROCESSOR ARCHITECTURE .....  | 1-1 |
| 1.1.1 | Parallel Instruction Execution .....                 | 1-1 |
| 1.1.2 | Full Procedure Call Model .....                      | 1-3 |
| 1.1.3 | Versatile Instruction Set and Addressing .....       | 1-3 |
| 1.1.4 | Integrated Priority Interrupt Model .....            | 1-3 |
| 1.1.5 | Complete Fault Handling and Debug Capabilities ..... | 1-4 |
| 1.2   | SYSTEM INTEGRATION .....                             | 1-4 |
| 1.2.1 | Pipelined Burst Bus Control Unit .....               | 1-4 |
| 1.2.2 | Flexible DMA Controller .....                        | 1-4 |
| 1.2.3 | Priority Interrupt Controller .....                  | 1-5 |
| 1.3   | ABOUT THIS MANUAL.....                               | 1-5 |
| 1.4   | NOTATION AND TERMINOLOGY.....                        | 1-6 |
| 1.4.1 | Reserved and Preserved .....                         | 1-6 |
| 1.4.2 | Specifying Bit and Signal Values .....               | 1-7 |
| 1.4.3 | Representing Numbers .....                           | 1-7 |
| 1.4.4 | Register Names .....                                 | 1-7 |

**CHAPTER 2**

**PROGRAMMING ENVIRONMENT**

|         |   |      |
|---------|---|------|
| 2.1     | OVERVIEW.....   | 2-1  |
| 2.2     | REGISTERS AND LITERALS AS INSTRUCTION OPERANDS .....      | 2-1  |
| 2.2.1   | Global Registers .....                                    | 2-2  |
| 2.2.2   | Local Registers .....                                     | 2-3  |
| 2.2.3   | Special Function Registers (SFRs) .....                   | 2-4  |
| 2.2.4   | Register Scoreboarding .....                              | 2-4  |
| 2.2.5   | Literals .....  | 2-5  |
| 2.2.6   | Register and Literal Addressing and Alignment .....       | 2-5  |
| 2.3     | CONTROL REGISTERS.....                                    | 2-6  |
| 2.4     | ARCHITECTURE-DEFINED DATA STRUCTURES .....                | 2-8  |
| 2.5     | MEMORY ADDRESS SPACE.....                                 | 2-9  |
| 2.5.1   | Memory Requirements .....                                 | 2-10 |
| 2.5.2   | Data and Instruction Alignment in the Address Space ..... | 2-11 |
| 2.5.3   | Byte, Word and Bit Addressing .....                       | 2-11 |
| 2.5.4   | Internal Data RAM .....                                   | 2-12 |
| 2.5.5   | Instruction Cache .....                                   | 2-13 |
| 2.5.6   | Data Cache (80960CF Only) .....                           | 2-14 |
| 2.6     | PROCESSOR-STATE REGISTERS.....                            | 2-14 |
| 2.6.1   | Instruction Pointer (IP) Register .....                   | 2-15 |
| 2.6.2   | Arithmetic Controls (AC) Register .....                   | 2-15 |
| 2.6.2.1 | Initializing and Modifying the AC Register .....          | 2-16 |
| 2.6.2.2 | Condition Code .....                                      | 2-16 |



## CONTENTS

|         |  |      |
|---------|--|------|
| 2.6.3   | Process Controls (PC) Register .....             | 2-17 |
| 2.6.3.1 | Initializing and Modifying the PC Register ..... | 2-19 |
| 2.6.4   | Trace Controls (TC) Register .....               | 2-20 |
| 2.7     | USER SUPERVISOR PROTECTION MODEL.....            | 2-20 |
| 2.7.1   | Supervisor Mode Resources .....                  | 2-20 |
| 2.7.2   | Using the User-Supervisor Protection Model ..... | 2-21 |

## CHAPTER 3

### DATA TYPES AND MEMORY ADDRESSING MODES

|       |                                |     |
|-------|--------------------------------|-----|
| 3.1   | DATA TYPES .....               | 3-1 |
| 3.1.1 | Integers .....                 | 3-2 |
| 3.1.2 | Ordinals .....                 | 3-3 |
| 3.1.3 | Bits and Bit Fields .....      | 3-3 |
| 3.1.4 | Triple and Quad Words .....    | 3-4 |
| 3.1.5 | Data Alignment .....           | 3-4 |
| 3.2   | BYTE ORDERING.....             | 3-4 |
| 3.3   | MEMORY ADDRESSING MODES .....  | 3-5 |
| 3.3.1 | Absolute .....                 | 3-6 |
| 3.3.2 | Register Indirect .....        | 3-6 |
| 3.3.3 | Index with Displacement .....  | 3-7 |
| 3.3.4 | IP with Displacement .....     | 3-7 |
| 3.3.5 | Addressing Mode Examples ..... | 3-7 |

## CHAPTER 4

### INSTRUCTION SET SUMMARY

|         |  |      |
|---------|--|------|
| 4.1     | INSTRUCTION FORMATS .....                | 4-1  |
| 4.1.1   | Assembly Language Format .....           | 4-1  |
| 4.1.2   | Branch Prediction .....                  | 4-2  |
| 4.1.3   | Instruction Encoding Formats .....       | 4-2  |
| 4.1.4   | Instruction Operands .....               | 4-3  |
| 4.2     | INSTRUCTION GROUPS .....                 | 4-4  |
| 4.2.1   | Data Movement .....                      | 4-5  |
| 4.2.1.1 | Load and Store Instructions .....        | 4-5  |
| 4.2.1.2 | Move .....                               | 4-6  |
| 4.2.1.3 | Load Address .....                       | 4-6  |
| 4.2.2   | Arithmetic .....                         | 4-6  |
| 4.2.2.1 | Add, Subtract, Multiply and Divide ..... | 4-7  |
| 4.2.2.2 | Extended Arithmetic .....                | 4-8  |
| 4.2.2.3 | Remainder and Modulo .....               | 4-8  |
| 4.2.2.4 | Shift and Rotate .....                   | 4-9  |
| 4.2.3   | Logical .....                            | 4-10 |
| 4.2.4   | Bit and Bit Field .....                  | 4-10 |
| 4.2.4.1 | Bit Operations .....                     | 4-10 |
| 4.2.4.2 | Bit Field Operations .....               | 4-11 |



- 4.2.5 Byte Operations ..... 4-12
- 4.2.6 Comparison ..... 4-12
  - 4.2.6.1 Compare and Conditional Compare ..... 4-12
  - 4.2.6.2 Compare and Increment or Decrement ..... 4-13
  - 4.2.6.3 Test Condition Codes ..... 4-13
- 4.2.7 Branch ..... 4-13
  - 4.2.7.1 Unconditional Branch ..... 4-14
  - 4.2.7.2 Conditional Branch ..... 4-15
  - 4.2.7.3 Compare and Branch ..... 4-15
- 4.2.8 Call and Return ..... 4-16
- 4.2.9 Conditional Faults ..... 4-17
- 4.2.10 Debug ..... 4-17
- 4.2.11 Atomic Instructions ..... 4-18
- 4.2.12 Processor Management ..... 4-18
- 4.3 SYSTEM CONTROL FUNCTIONS ..... 4-19
  - 4.3.1 **sysctl** Instruction Syntax ..... 4-19
  - 4.3.2 System Control Messages ..... 4-20
    - 4.3.2.1 Request Interrupt ..... 4-21
    - 4.3.2.2 Invalidate Instruction Cache ..... 4-21
    - 4.3.2.3 Configure Instruction Cache ..... 4-21
    - 4.3.2.4 Reinitialize Processor ..... 4-22
    - 4.3.2.5 Load Control Registers ..... 4-23

**CHAPTER 5  
PROCEDURE CALLS**

- 5.1 OVERVIEW ..... 5-1
- 5.2 CALL AND RETURN MECHANISM ..... 5-2
  - 5.2.1 Local Registers and the Procedure Stack ..... 5-2
  - 5.2.2 Local Register and Stack Management ..... 5-4
    - 5.2.2.1 Frame Pointer ..... 5-4
    - 5.2.2.2 Stack Pointer ..... 5-4
    - 5.2.2.3 Previous Frame Pointer ..... 5-4
    - 5.2.2.4 Return Type Field ..... 5-4
    - 5.2.2.5 Return Instruction Pointer ..... 5-5
  - 5.2.3 Call and Return Action ..... 5-5
    - 5.2.3.1 Call Operation ..... 5-5
    - 5.2.3.2 Return Operation ..... 5-6
  - 5.2.4 Caching of Local Register Sets ..... 5-6
  - 5.2.5 Mapping Local Registers to the Procedure Stack ..... 5-9
- 5.3 PARAMETER PASSING ..... 5-10
- 5.4 LOCAL CALLS ..... 5-12
- 5.5 SYSTEM CALLS ..... 5-12
  - 5.5.1 System Procedure Table ..... 5-13
    - 5.5.1.1 Procedure Entries ..... 5-14
    - 5.5.1.2 Supervisor Stack Pointer ..... 5-14



## CONTENTS

|         |   |      |
|---------|---|------|
| 5.5.1.3 | Trace Control Bit .....                     | 5-14 |
| 5.5.2   | System Call to a Local Procedure .....      | 5-15 |
| 5.5.3   | System Call to a Supervisor Procedure ..... | 5-15 |
| 5.6     | USER AND SUPERVISOR STACKS .....            | 5-15 |
| 5.7     | INTERRUPT AND FAULT CALLS.....              | 5-16 |
| 5.8     | RETURNS .....                               | 5-16 |
| 5.9     | BRANCH-AND-LINK .....                       | 5-18 |

## CHAPTER 6 INTERRUPTS

|       |  |      |
|-------|--|------|
| 6.1   | OVERVIEW .....   | 6-1  |
| 6.2   | SOFTWARE REQUIREMENTS FOR INTERRUPT HANDLING .....       | 6-2  |
| 6.3   | INTERRUPT PRIORITY .....                                 | 6-3  |
| 6.4   | INTERRUPT TABLE.....                                     | 6-3  |
| 6.4.1 | Vector Entries .....                                     | 6-4  |
| 6.4.2 | Pending Interrupts .....                                 | 6-5  |
| 6.4.3 | Caching Portions of the Interrupt Table .....            | 6-5  |
| 6.5   | REQUESTING INTERRUPTS.....                               | 6-6  |
| 6.5.1 | Posting Interrupts .....                                 | 6-6  |
| 6.5.2 | Posting Interrupts Directly to the Interrupt Table ..... | 6-7  |
| 6.6   | SYSTEM CONTROL INSTRUCTION (sysctl) .....                | 6-8  |
| 6.7   | INTERRUPT STACK AND INTERRUPT RECORD .....               | 6-9  |
| 6.8   | INTERRUPT SERVICE ROUTINES.....                          | 6-10 |
| 6.9   | INTERRUPT CONTEXT SWITCH.....                            | 6-11 |
| 6.9.1 | Executing-State Interrupt .....                          | 6-12 |
| 6.9.2 | Interrupted-State Interrupt .....                        | 6-13 |

## CHAPTER 7 FAULTS

|       |   |     |
|-------|---|-----|
| 7.1   | FAULT HANDLING FACILITIES OVERVIEW .....                          | 7-1 |
| 7.2   | FAULT TYPES .....   | 7-2 |
| 7.3   | FAULT TABLE.....  | 7-4 |
| 7.4   | STACK USED IN FAULT HANDLING .....                                | 7-6 |
| 7.5   | FAULT RECORD.....   | 7-6 |
| 7.5.1 | Fault Record Data .....   | 7-6 |
| 7.5.2 | Return Instruction Pointer (RIP) .....                            | 7-7 |
| 7.5.3 | Fault Record Location .....                                       | 7-8 |
| 7.6   | MULTIPLE AND PARALLEL FAULTS .....                                | 7-9 |
| 7.6.1 | Multiple Faults .....   | 7-9 |
| 7.6.2 | Multiple Trace Fault Conditions Only .....                        | 7-9 |
| 7.6.3 | Multiple Trace Fault Conditions with Other Fault Conditions ..... | 7-9 |
| 7.6.4 | Parallel Faults .....   | 7-9 |

|        |   |      |
|--------|---|------|
| 7.6.5  | Faults in One Parallel Instruction .....                                      | 7-10 |
| 7.6.6  | Faults in Multiple Parallel Instructions .....                                | 7-10 |
| 7.6.7  | Fault Record for Parallel Faults .....  | 7-10 |
| 7.7    | <b>FAULT HANDLING PROCEDURES</b> .....  | 7-12 |
| 7.7.1  | Possible Fault Handling Procedure Actions .....                               | 7-12 |
| 7.7.2  | Program Resumption Following a Fault .....                                    | 7-12 |
| 7.7.3  | Returning to the Point in the Program Where the Fault Occurred .....          | 7-13 |
| 7.7.4  | Returning to a Point in the Program Other Than Where the Fault Occurred ..... | 7-13 |
| 7.7.5  | Fault Controls .....  | 7-14 |
| 7.8    | <b>FAULT HANDLING ACTION</b> .....  | 7-14 |
| 7.8.1  | Local Fault Call .....  | 7-15 |
| 7.8.2  | System-Local Fault Call .....   | 7-16 |
| 7.8.3  | System-Supervisor Fault Call .....  | 7-16 |
| 7.8.4  | Faults and Interrupts .....   | 7-17 |
| 7.9    | <b>PRECISE AND IMPRECISE FAULTS</b> .....                                     | 7-17 |
| 7.9.1  | Precise Faults .....  | 7-18 |
| 7.9.2  | Imprecise Faults .....  | 7-18 |
| 7.9.3  | Asynchronous Faults .....   | 7-18 |
| 7.9.4  | No Imprecise Faults (NIF) Bit .....   | 7-18 |
| 7.9.5  | Controlling Fault Precision .....   | 7-19 |
| 7.10   | <b>FAULT REFERENCE</b> .....  | 7-20 |
| 7.10.1 | Arithmetic Faults .....   | 7-21 |
| 7.10.2 | Constraint Faults .....   | 7-22 |
| 7.10.3 | Operation Faults .....  | 7-23 |
| 7.10.4 | Parallel Faults .....   | 7-24 |
| 7.10.5 | Protection Faults .....   | 7-25 |
| 7.10.6 | Trace Faults .....  | 7-26 |
| 7.10.7 | Type Faults .....   | 7-28 |

**CHAPTER 8**  
**TRACING AND DEBUGGING**

|       |   |     |
|-------|---|-----|
| 8.1   | <b>TRACE CONTROLS</b> .....                         | 8-1 |
| 8.1.1 | Trace Controls (TC) Register .....                  | 8-2 |
| 8.1.2 | Trace Enable Bit and Trace-Fault-Pending Flag ..... | 8-3 |
| 8.1.3 | Trace Control on Supervisor Calls .....             | 8-3 |
| 8.2   | <b>TRACE MODES</b> .....                            | 8-4 |
| 8.2.1 | Instruction Trace .....                             | 8-4 |
| 8.2.2 | Branch Trace .....                                  | 8-4 |
| 8.2.3 | Call Trace .....                                    | 8-4 |
| 8.2.4 | Return Trace .....                                  | 8-4 |
| 8.2.5 | Prereturn Trace .....                               | 8-5 |
| 8.2.6 | Supervisor Trace .....                              | 8-5 |
| 8.2.7 | Breakpoint Trace .....                              | 8-5 |



## CONTENTS

|         |  |     |
|---------|--|-----|
| 8.2.7.1 | Software Breakpoints .....             | 8-5 |
| 8.2.7.2 | Hardware Breakpoints .....             | 8-5 |
| 8.3     | SIGNALING A TRACE EVENT .....          | 8-7 |
| 8.4     | HANDLING MULTIPLE TRACE EVENTS.....    | 8-8 |
| 8.5     | TRACE FAULT HANDLING PROCEDURE .....   | 8-8 |
| 8.6     | TRACE HANDLING ACTION .....            | 8-9 |
| 8.6.1   | Normal Handling of Trace Events .....  | 8-9 |
| 8.6.2   | Prereturn Trace Handling .....         | 8-9 |
| 8.6.3   | Tracing and Interrupt Procedures ..... | 8-9 |

## CHAPTER 9

### INSTRUCTION SET REFERENCE

|        |                                     |      |
|--------|-------------------------------------|------|
| 9.1    | INTRODUCTION.....                   | 9-1  |
| 9.2    | NOTATION.....                       | 9-1  |
| 9.2.1  | Alphabetic Reference .....          | 9-2  |
| 9.2.2  | Mnemonic .....                      | 9-2  |
| 9.2.3  | Format .....                        | 9-3  |
| 9.2.4  | Description .....                   | 9-3  |
| 9.2.5  | Action .....                        | 9-4  |
| 9.2.6  | Faults .....                        | 9-6  |
| 9.2.7  | Example .....                       | 9-7  |
| 9.2.8  | Opcode and Instruction Format ..... | 9-7  |
| 9.2.9  | See Also .....                      | 9-7  |
| 9.3    | INSTRUCTIONS.....                   | 9-7  |
| 9.3.1  | <b>addc</b> .....                   | 9-8  |
| 9.3.2  | <b>addi, addo</b> .....             | 9-9  |
| 9.3.3  | <b>alterbit</b> .....               | 9-10 |
| 9.3.4  | <b>and, andnot</b> .....            | 9-11 |
| 9.3.5  | <b>atadd</b> .....                  | 9-12 |
| 9.3.6  | <b>atmod</b> .....                  | 9-13 |
| 9.3.7  | <b>b, bx</b> .....                  | 9-14 |
| 9.3.8  | <b>bal, balx</b> .....              | 9-15 |
| 9.3.9  | <b>bbc, bbs</b> .....               | 9-17 |
| 9.3.10 | <b>BRANCH IF</b> .....              | 9-19 |
| 9.3.11 | <b>call</b> .....                   | 9-21 |
| 9.3.12 | <b>calls</b> .....                  | 9-22 |
| 9.3.13 | <b>callx</b> .....                  | 9-24 |
| 9.3.14 | <b>chkbit</b> .....                 | 9-26 |
| 9.3.15 | <b>clrbit</b> .....                 | 9-27 |
| 9.3.16 | <b>cmpdeci, cmpdeco</b> .....       | 9-28 |
| 9.3.17 | <b>cmpi, cmpo</b> .....             | 9-29 |
| 9.3.18 | <b>cmpinci, cmpinco</b> .....       | 9-30 |
| 9.3.19 | <b>COMPARE AND BRANCH</b> .....     | 9-31 |





|        |  |      |
|--------|--|------|
| 9.3.20 | <b>concmpi, concmpo</b> .....                | 9-34 |
| 9.3.21 | <b>divi, divo</b> .....                      | 9-35 |
| 9.3.22 | <b>ediv</b> .....                            | 9-36 |
| 9.3.23 | <b>emul</b> .....                            | 9-37 |
| 9.3.24 | <b>eshro</b> (80960Cx Processor Only) .....  | 9-38 |
| 9.3.25 | <b>extract</b> .....                         | 9-39 |
| 9.3.26 | <b>FAULT IF</b> .....                        | 9-40 |
| 9.3.27 | <b>flushreg</b> .....                        | 9-42 |
| 9.3.28 | <b>fmark</b> .....                           | 9-43 |
| 9.3.29 | <b>LOAD</b> .....                            | 9-44 |
| 9.3.30 | <b>lda</b> .....                             | 9-46 |
| 9.3.31 | <b>mark</b> .....                            | 9-47 |
| 9.3.32 | <b>modac</b> .....                           | 9-48 |
| 9.3.33 | <b>modi</b> .....                            | 9-49 |
| 9.3.34 | <b>modify</b> .....                          | 9-50 |
| 9.3.35 | <b>modpc</b> .....                           | 9-51 |
| 9.3.36 | <b>modtc</b> .....                           | 9-52 |
| 9.3.37 | <b>MOVE</b> .....                            | 9-53 |
| 9.3.38 | <b>muli, mulo</b> .....                      | 9-54 |
| 9.3.39 | <b>nand</b> .....                            | 9-55 |
| 9.3.40 | <b>nor</b> .....                             | 9-56 |
| 9.3.41 | <b>not, notand</b> .....                     | 9-57 |
| 9.3.42 | <b>notbit</b> .....                          | 9-58 |
| 9.3.43 | <b>notor</b> .....                           | 9-59 |
| 9.3.44 | <b>or, ornot</b> .....                       | 9-60 |
| 9.3.45 | <b>remi, remo</b> .....                      | 9-61 |
| 9.3.46 | <b>ret</b> .....                             | 9-62 |
| 9.3.47 | <b>rotate</b> .....                          | 9-64 |
| 9.3.48 | <b>scanbit</b> .....                         | 9-65 |
| 9.3.49 | <b>scanbyte</b> .....                        | 9-66 |
| 9.3.50 | <b>sdma</b> (80960Cx Processor Only) .....   | 9-67 |
| 9.3.51 | <b>setbit</b> .....                          | 9-68 |
| 9.3.52 | <b>SHIFT</b> .....                           | 9-69 |
| 9.3.53 | <b>spanbit</b> .....                         | 9-72 |
| 9.3.54 | <b>STORE</b> .....                           | 9-73 |
| 9.3.55 | <b>subc</b> .....                            | 9-75 |
| 9.3.56 | <b>subi, subo</b> .....                      | 9-76 |
| 9.3.57 | <b>syncf</b> .....                           | 9-77 |
| 9.3.58 | <b>sysctl</b> (80960Cx Processor Only) ..... | 9-78 |
| 9.3.59 | <b>TEST</b> .....                            | 9-81 |
| 9.3.60 | <b>udma</b> (80960Cx Processor Only) .....   | 9-83 |
| 9.3.61 | <b>xnor, xor</b> .....                       | 9-84 |



# CONTENTS

## CHAPTER 10

### THE BUS CONTROLLER

|        |   |       |
|--------|---|-------|
| 10.1   | OVERVIEW .....  | 10-1  |
| 10.2   | MEMORY REGION CONFIGURATION .....                       | 10-2  |
| 10.2.1 | Data Bus Width .....                                    | 10-3  |
| 10.2.2 | Burst and Pipelined Read Accesses .....                 | 10-3  |
| 10.2.3 | Wait States .....                                       | 10-3  |
| 10.2.4 | Byte Ordering .....                                     | 10-5  |
| 10.3   | PROGRAMMING THE BUS CONTROLLER .....                    | 10-5  |
| 10.3.1 | Memory Region Configuration Registers (MCON 0-15) ..... | 10-6  |
| 10.3.2 | Bus Configuration Register (BCON) .....                 | 10-8  |
| 10.3.3 | Configuring the Bus Controller .....                    | 10-9  |
| 10.4   | DATA ALIGNMENT .....                                    | 10-9  |
| 10.5   | INTERNAL DATA RAM .....                                 | 10-13 |
| 10.6   | BUS CONTROLLER IMPLEMENTATION .....                     | 10-13 |
| 10.6.1 | Bus Queue .....   | 10-14 |
| 10.6.2 | Data Packing Unit .....                                 | 10-15 |
| 10.6.3 | Bus Translation Unit and Sequencer .....                | 10-15 |

## CHAPTER 11

### EXTERNAL BUS DESCRIPTION

|          |   |       |
|----------|---|-------|
| 11.1     | OVERVIEW .....  | 11-1  |
| 11.1.1   | Terminology: Requests and Accesses .....                      | 11-1  |
| 11.1.1.1 | Request .....   | 11-1  |
| 11.1.1.2 | Access .....  | 11-2  |
| 11.1.2   | Configuration .....   | 11-2  |
| 11.2     | BUS OPERATION .....   | 11-2  |
| 11.2.1   | Wait States .....   | 11-4  |
| 11.2.2   | Bus Width .....   | 11-10 |
| 11.2.3   | Non-Burst Requests .....                                      | 11-12 |
| 11.2.4   | Burst Accesses .....  | 11-13 |
| 11.2.5   | Pipelined Read Accesses .....                                 | 11-21 |
| 11.3     | LITTLE OR BIG ENDIAN MEMORY CONFIGURATION .....               | 11-24 |
| 11.4     | ATOMIC MEMORY OPERATIONS (The $\overline{LOCK}$ Signal) ..... | 11-26 |
| 11.5     | EXTERNAL BUS ARBITRATION .....                                | 11-28 |
| 11.5.1   | Bus Backoff Function ( $\overline{BOFF}$ pin) .....           | 11-29 |

## CHAPTER 12

### INTERRUPT CONTROLLER

|          |                                   |      |
|----------|-----------------------------------|------|
| 12.1     | OVERVIEW .....                    | 12-1 |
| 12.2     | MANAGING INTERRUPT REQUESTS ..... | 12-2 |
| 12.2.1   | Interrupt Controller Modes .....  | 12-3 |
| 12.2.1.1 | Dedicated Mode .....              | 12-4 |



- 12.2.1.2 Expanded Mode ..... 12-5
- 12.2.1.3 Mixed Mode ..... 12-7
- 12.2.2 Non-Maskable Interrupt (NMI) ..... 12-7
- 12.2.3 Saving the Interrupt Mask ..... 12-7
- 12.3 EXTERNAL INTERFACE DESCRIPTION ..... 12-8
  - 12.3.1 Pin Descriptions ..... 12-9
  - 12.3.2 Interrupt Detection Options ..... 12-9
  - 12.3.3 Programmer’s Interface ..... 12-11
  - 12.3.4 Interrupt Control Register (ICON) ..... 12-11
  - 12.3.5 Interrupt Mapping Registers (IMAP0-IMAP2) ..... 12-12
  - 12.3.6 Interrupt Mask and Pending Registers (IMSK, IPND) ..... 12-14
  - 12.3.7 Default and Reset Register Values ..... 12-15
  - 12.3.8 Setting Up the Interrupt Controller ..... 12-16
  - 12.3.9 Implementation ..... 12-16
  - 12.3.10 Interrupt Service Latency ..... 12-17
  - 12.3.11 Optimizing Interrupt Performance ..... 12-19
  - 12.3.12 Vector Caching Option ..... 12-20
  - 12.3.13 DMA Suspension on Interrupts ..... 12-21
  - 12.3.14 Caching Interrupt-Handling Procedures ..... 12-21

**CHAPTER 13  
DMA CONTROLLER**

- 13.1 OVERVIEW ..... 13-1
- 13.2 DEMAND AND BLOCK MODE DMA ..... 13-2
- 13.3 SOURCE AND DESTINATION ADDRESSING ..... 13-3
- 13.4 DMA TRANSFERS ..... 13-3
  - 13.4.1 Multi-Cycle Transfers ..... 13-3
  - 13.4.2 Fly-By Single-Cycle Transfers ..... 13-5
  - 13.4.3 Source/Destination Request Length ..... 13-6
  - 13.4.4 Assembly and Disassembly ..... 13-9
  - 13.4.5 Data Alignment ..... 13-10
- 13.5 DATA CHAINING ..... 13-13
- 13.6 DMA-SOURCED INTERRUPTS ..... 13-16
- 13.7 SYNCHRONIZING A PROGRAM TO CHAINED BUFFER TRANSFERS ..... 13-17
- 13.8 TERMINATING A DMA ..... 13-18
- 13.9 CHANNEL PRIORITY ..... 13-20
- 13.10 CHANNEL SETUP, STATUS AND CONTROL ..... 13-20
  - 13.10.1 DMA Command Register (DMAC) ..... 13-21
  - 13.10.2 Set Up DMA Instruction (**sdma**) ..... 13-24
  - 13.10.3 DMA Control Word ..... 13-25
  - 13.10.4 DMA Data RAM ..... 13-27
  - 13.10.5 Channel Setup Examples ..... 13-29
- 13.11 DMA EXTERNAL INTERFACE ..... 13-30



## CONTENTS

|          |  |       |
|----------|--|-------|
| 13.11.1  | Pin Description .....                        | 13-30 |
| 13.11.2  | Demand Mode Request/Acknowledge Timing ..... | 13-31 |
| 13.11.3  | End Of Process/Terminal Count Timing .....   | 13-32 |
| 13.11.4  | Block Mode Transfers .....                   | 13-33 |
| 13.11.5  | DMA Bus Request Pin .....                    | 13-33 |
| 13.11.6  | DMA Controller Implementation .....          | 13-34 |
| 13.11.7  | DMA and User Program Processes .....         | 13-34 |
| 13.11.8  | Bus Controller Unit .....                    | 13-35 |
| 13.11.9  | DMA Controller Logic .....                   | 13-35 |
| 13.11.10 | DMA Performance .....                        | 13-36 |
| 13.11.11 | DMA Throughput .....                         | 13-38 |
| 13.11.12 | DMA Latency .....                            | 13-40 |

## CHAPTER 14

### INITIALIZATION AND SYSTEM REQUIREMENTS

|          |   |       |
|----------|---|-------|
| 14.1     | OVERVIEW .....  | 14-1  |
| 14.2     | INITIALIZATION .....  | 14-2  |
| 14.2.1   | Reset Operation .....                                       | 14-2  |
| 14.2.2   | Self Test Function (STEST, $\overline{\text{FAIL}}$ ) ..... | 14-4  |
| 14.2.3   | On-Circuit Emulation .....                                  | 14-5  |
| 14.2.4   | Initial Memory Image (IMI) .....                            | 14-5  |
| 14.2.5   | Initialization Boot Record (IBR) .....                      | 14-5  |
| 14.2.6   | Process Control Block (PRCB) .....                          | 14-8  |
| 14.3     | REQUIRED DATA STRUCTURES .....                              | 14-11 |
| 14.3.1   | Reinitializing and Relocating Data Structures .....         | 14-11 |
| 14.3.2   | Initialization Flow .....                                   | 14-12 |
| 14.3.3   | Startup Code Example .....                                  | 14-14 |
| 14.4     | SYSTEM REQUIREMENTS.....                                    | 14-26 |
| 14.4.1   | Input Clock (CLKIN) .....                                   | 14-26 |
| 14.4.2   | Power and Ground Requirements ( $V_{CC}$ , $V_{SS}$ ) ..... | 14-27 |
| 14.4.3   | Power and Ground Planes .....                               | 14-27 |
| 14.4.4   | Decoupling Capacitors .....                                 | 14-28 |
| 14.4.5   | I/O Pin Characteristics .....                               | 14-28 |
| 14.4.5.1 | Output Pins .....   | 14-28 |
| 14.4.5.2 | Input Pins .....  | 14-29 |
| 14.4.6   | High Frequency Design Considerations .....                  | 14-29 |
| 14.4.7   | Line Termination .....                                      | 14-30 |
| 14.4.8   | Latchup .....   | 14-31 |
| 14.4.9   | Interference .....  | 14-31 |



APPENDIX A

INSTRUCTION EXECUTION AND PERFORMANCE OPTIMIZATION

|          |   |      |
|----------|---|------|
| A.1      | INTERNAL PROCESSOR STRUCTURE.....                             | A-2  |
| A.1.1    | Instruction Scheduler (IS) .....                              | A-3  |
| A.1.2    | Instruction Flow .....  | A-4  |
| A.1.3    | Register File (RF) .....                                      | A-6  |
| A.1.4    | Execution Unit (EU) .....                                     | A-7  |
| A.1.5    | Multiply/Divide Unit (MDU) .....                              | A-7  |
| A.1.6    | Address Generation Unit (AGU) .....                           | A-7  |
| A.1.7    | Data RAM and Local Register Cache .....                       | A-7  |
| A.1.8    | Data Cache (80960CF Only) .....                               | A-8  |
| A.1.8.1  | Data Cache Organization .....                                 | A-8  |
| A.1.8.2  | Bus Configuration .....                                       | A-9  |
| A.1.8.3  | Global Control of the Cache .....                             | A-9  |
| A.1.8.4  | Data Fetch Policy .....                                       | A-10 |
| A.1.8.5  | Write Policy .....  | A-10 |
| A.1.8.6  | Data Cache Coherency .....                                    | A-10 |
| A.1.8.7  | BCU Pipeline and Data Cache Interaction .....                 | A-11 |
| A.1.8.8  | BCU Queues and Cache Coherency .....                          | A-12 |
| A.1.8.9  | DMA Operation and Data Coherency .....                        | A-13 |
| A.1.8.10 | External I/O and Bus Masters and Cache Coherency .....        | A-13 |
| A.2      | PARALLEL INSTRUCTION PROCESSING.....                          | A-14 |
| A.2.1    | Parallel Issue .....  | A-14 |
| A.2.2    | Parallel Execution .....                                      | A-15 |
| A.2.3    | Scoreboarding .....   | A-17 |
| A.2.3.1  | Register Scoreboarding .....                                  | A-18 |
| A.2.3.2  | Resource Scoreboarding .....                                  | A-18 |
| A.2.3.3  | Prevention of Pipeline Stalls .....                           | A-18 |
| A.2.3.4  | Additional Scoreboarded Resources Due to the Data Cache ..... | A-19 |
| A.2.4    | Processing Units .....  | A-20 |
| A.2.4.1  | Execution Unit (EU) .....                                     | A-20 |
| A.2.4.2  | Multiply/Divide Unit (MDU) .....                              | A-22 |
| A.2.4.3  | Data RAM (DR) .....   | A-24 |
| A.2.4.4  | Address Generation Unit (AGU) .....                           | A-25 |
| A.2.4.5  | Effective Address ( <i>efa</i> ) Calculations .....           | A-26 |
| A.2.4.6  | Bus Control Unit (BCU) .....                                  | A-26 |
| A.2.4.7  | Control Pipeline .....  | A-28 |
| A.2.4.8  | Unconditional Branches .....                                  | A-28 |
| A.2.4.9  | Conditional Branches .....                                    | A-32 |
| A.2.5    | Instruction Cache And Fetch Execution .....                   | A-33 |
| A.2.5.1  | Instruction Cache Organization .....                          | A-33 |
| A.2.5.2  | Fetch Strategy .....  | A-34 |
| A.2.5.3  | Fetch Latency .....   | A-34 |
| A.2.5.4  | Cache Replacement .....                                       | A-36 |
| A.2.6    | Micro-flow Execution .....                                    | A-36 |
| A.2.6.1  | Invocation and Execution .....                                | A-37 |

## CONTENTS

|          |  |      |
|----------|--|------|
| A.2.6.2  | Data Movement .....                          | A-38 |
| A.2.6.3  | Bit and Bit Field .....                      | A-39 |
| A.2.6.4  | Comparison .....                             | A-40 |
| A.2.6.5  | Branch .....                                 | A-40 |
| A.2.6.6  | Call and Return .....                        | A-41 |
| A.2.6.7  | Conditional Faults .....                     | A-42 |
| A.2.6.8  | Debug .....                                  | A-42 |
| A.2.6.9  | Atomic .....                                 | A-42 |
| A.2.6.10 | Processor Management .....                   | A-42 |
| A.2.7    | Coding Optimizations .....                   | A-43 |
| A.2.7.1  | Loads and Stores .....                       | A-44 |
| A.2.7.2  | Multiplication and Division .....            | A-45 |
| A.2.7.3  | Advancing Comparisons .....                  | A-46 |
| A.2.7.4  | Unrolling Loops .....                        | A-46 |
| A.2.7.5  | Enabling Constant Parallel Issue .....       | A-48 |
| A.2.7.6  | Alternating from Side to Side .....          | A-49 |
| A.2.7.7  | Branch Prediction .....                      | A-53 |
| A.2.7.8  | Branch Target Alignment .....                | A-53 |
| A.2.7.9  | Replacing Straight-Line Code and Calls ..... | A-54 |
| A.2.8    | Utilizing On-chip Storage .....              | A-55 |
| A.2.8.1  | Instruction Cache .....                      | A-55 |
| A.2.8.2  | Data Cache (i960 CF Processor Only) .....    | A-55 |
| A.2.8.3  | Register Cache .....                         | A-56 |
| A.2.8.4  | Data RAM .....                               | A-56 |
| A.2.9    | Summary .....                                | A-57 |

## APPENDIX B

### BUS INTERFACE EXAMPLES

|         |  |      |
|---------|--|------|
| B.1     | NON-PIPELINED BURST SRAM INTERFACE .....   | B-1  |
| B.1.1   | Background .....                           | B-1  |
| B.1.2   | Implementation .....                       | B-1  |
| B.1.3   | Block Diagram .....                        | B-2  |
| B.1.3.1 | Chip Select Logic .....                    | B-3  |
| B.1.3.2 | State Machine PLD .....                    | B-3  |
| B.1.3.3 | Write Enable Generation Logic .....        | B-3  |
| B.1.3.4 | Chip Select Generation .....               | B-3  |
| B.1.4   | Waveforms .....                            | B-4  |
| B.1.4.1 | Wait State Selection .....                 | B-5  |
| B.1.4.2 | Output Enable and Write Enable Logic ..... | B-6  |
| B.1.4.3 | State Machine Descriptions .....           | B-6  |
| B.1.5   | Trade-offs and Alternatives .....          | B-10 |
| B.2     | PIPELINED SRAM READ INTERFACE .....        | B-10 |
| B.2.1   | Block Diagram .....                        | B-11 |
| B.2.1.1 | Address Latch .....                        | B-12 |
| B.2.1.2 | State Machine PLD .....                    | B-12 |
| B.2.1.3 | Write Enable Logic .....                   | B-12 |



- B.2.2 Waveforms ..... B-13
  - B.2.2.1 State Machines ..... B-13
- B.2.3 Trade-offs and Alternatives ..... B-15
- B.3 INTERFACING TO DYNAMIC RAM..... B-15
  - B.3.1 DRAM Access Modes ..... B-15
    - B.3.1.1 Nibble Mode DRAM ..... B-16
    - B.3.1.2 Fast Page Mode DRAM ..... B-17
    - B.3.1.3 Static Column Mode DRAM ..... B-18
  - B.3.2 DRAM Refresh Modes ..... B-18
  - B.3.3 Address Multiplexer Input Connections ..... B-20
  - B.3.4 Series Damping Resistors ..... B-20
  - B.3.5 System Loading ..... B-21
  - B.3.6 Design Example: Burst DRAM with Distributed  $\overline{\text{RAS}}$  Only Refresh Using DMA ..... B-21
  - B.3.7 DRAM Address Generation ..... B-23
  - B.3.8 DRAM Controller State Machine ..... B-25
  - B.3.9 DRAM Refresh Request and Timer Logic ..... B-28
  - B.3.10 DMA Programming for Refresh ..... B-29
  - B.3.11 Memory Ready ..... B-29
  - B.3.12 Region Table Programming ..... B-29
  - B.3.13 Design Example: Burst DRAM with Distributed  $\overline{\text{CAS}}$ -Before- $\overline{\text{RAS}}$  Refresh Using  $\overline{\text{READY}}$  Control ..... B-32
  - B.3.14 DRAM Controller State Machine ..... B-33
- B.4 INTERLEAVED MEMORY SYSTEMS ..... B-37
- B.5 INTERFACING TO SLOW PERIPHERALS USING THE INTERNAL WAIT STATE GENERATOR ..... B-41
  - B.5.1 Implementation ..... B-41
  - B.5.2 Schematic ..... B-41
  - B.5.3 Waveforms ..... B-43

**APPENDIX C**

**CONSIDERATIONS FOR WRITING PORTABLE CODE**

- C.1 CORE ARCHITECTURE ..... C-1
- C.2 ADDRESS SPACE RESTRICTIONS ..... C-2
  - C.2.1 Reserved Memory ..... C-2
  - C.2.2 Internal Data RAM ..... C-2
  - C.2.3 Instruction Cache ..... C-2
  - C.2.4 Data Cache (80960CF Processor Only) ..... C-3
  - C.2.5 Data and Data Structure Alignment ..... C-3
- C.3 RESERVED LOCATIONS IN REGISTERS AND DATA STRUCTURES..... C-4
- C.4 INSTRUCTION SET ..... C-4
  - C.4.1 Instruction Timing ..... C-4
  - C.4.2 Implementation-Specific Instructions ..... C-4
- C.5 EXTENDED REGISTER SET..... C-5
- C.6 INITIALIZATION ..... C-5



**CONTENTS**

C.7 INTERRUPTS ..... C-5

C.8 OTHER i960 CA/CF PROCESSOR IMPLEMENTATION-SPECIFIC FEATURES..... C-6

    C.8.1 Data Control Peripheral Units ..... C-6

    C.8.2 Fault Implementation ..... C-6

C.9 BREAKPOINTS ..... C-6

C.10 LOCK PIN..... C-6

    C.10.1 External System Requirements ..... C-6

**APPENDIX D**

**MACHINE-LEVEL INSTRUCTION FORMATS**

D.1 GENERAL INSTRUCTION FORMAT..... D-1

D.2 REG FORMAT..... D-1

D.3 COBR FORMAT ..... D-3

D.4 CTRL FORMAT ..... D-3

D.5 MEM FORMAT ..... D-3

    D.5.1 MEMA Format Addressing ..... D-4

    D.5.2 MEMB Format Addressing ..... D-5

**APPENDIX E**

**MACHINE LANGUAGE INSTRUCTION REFERENCE**

E.1 INSTRUCTION REFERENCE BY OPCODE..... E-1

**APPENDIX F**

**REGISTER AND DATA STRUCTURES**

F.1 Data Structures ..... F-2

F.2 Registers ..... F-10

**GLOSSARY**

**INDEX**





FIGURES

Figure 1-1 i960<sup>®</sup> CA/CF Superscalar Microprocessor Architecture ..... 1-2

Figure 2-1 i960<sup>®</sup> Cx Microprocessor Programming Environment ..... 2-2

Figure 2-2 Control Table ..... 2-7

Figure 2-3 Address Space ..... 2-9

Figure 2-4 Arithmetic Controls (AC) Register..... 2-15

Figure 2-5 Process Controls (PC) Register ..... 2-18

Figure 2-6 Example Application of the User-Supervisor Protection Model ..... 2-22

Figure 3-1 Data Types and Ranges ..... 3-1

Figure 3-2 Data Placement in Registers ..... 3-5

Figure 4-1 Machine-Level Instruction Formats ..... 4-3

Figure 4-2 Source Operands for **sysctl** ..... 4-20

Figure 5-1 Procedure Stack Structure and Local Registers..... 5-3

Figure 5-2 Frame Spill ..... 5-7

Figure 5-3 Frame Fill..... 5-8

Figure 5-4 System Procedure Table ..... 5-13

Figure 5-5 Previous Frame Pointer Register (PFP) (r0)..... 5-16

Figure 6-1 Interrupt Handling Data Structures ..... 6-2

Figure 6-2 Interrupt Table ..... 6-4

Figure 6-3 Storage of an Interrupt Record on the Interrupt Stack..... 6-10

Figure 6-4 Flowchart for Worst Case Interrupt Latency ..... 6-14

Figure 7-1 Fault-Handling Data Structures ..... 7-1

Figure 7-2 Fault Table and Fault Table Entries ..... 7-5

Figure 7-3 Fault Record ..... 7-7

Figure 7-4 Storage of the Fault Record on the Stack ..... 7-8

Figure 7-5 Fault Record for Parallel Faults ..... 7-11

Figure 8-1 Trace Controls (TC) Register ..... 8-2

Figure 8-2 Instruction Address Breakpoint Registers (IPB0 - IPB1) ..... 8-6

Figure 8-3 Data Address Breakpoint Registers (DAB0 - DAB1) ..... 8-6

Figure 8-4 Hardware Breakpoint Control Register (BPCON)..... 8-7

Figure 10-1 MCON 0-15 Registers Configure External Memory..... 10-6

Figure 10-2 Memory Region Configuration Register (MCON 0-15) ..... 10-7

Figure 10-3 Bus Configuration Register (BCON) ..... 10-8

Figure 10-4 Summary of Aligned-Unaligned Transfers for Little Endian Regions..... 10-11

Figure 10-5 Summary of Aligned-Unaligned Transfers for Little Endian Regions (cont) ..... 10-12

Figure 10-6 Bus Controller Block Diagram ..... 10-14

Figure 11-1 Internal Programmable Wait States..... 11-6

Figure 11-2 Quad-word Read from 32-bit Non-burst Memory ..... 11-8

Figure 11-3 Bus Request with  $\overline{\text{READY}}$  and  $\overline{\text{BTERM}}$  Control ..... 11-9



## CONTENTS

|              |  |
|--------------|--|
| Figure 11-4  | Data Width and Byte Enable Encodings 11-10   |
| Figure 11-5  | Basic Read Request, Non-Pipelined, Non-Burst, Wait-States 11-12                          |
| Figure 11-6  | Read / Write Requests, Non-Pipelined, Non-Burst, No Wait States 11-14                    |
| Figure 11-7  | 32-Bit-Wide Data Bus Bursts 11-16  |
| Figure 11-8  | 16-Bit Wide Data Bus Bursts 11-17  |
| Figure 11-9  | 8-Bit Wide Data Bus Bursts 11-17   |
| Figure 11-10 | 32-Bit Bus, Burst, Non-Pipelined, Read Request with Wait States 11-19                    |
| Figure 11-11 | 32-Bit Bus, Burst, Non-Pipelined, Write Request without Wait States 11-20                |
| Figure 11-12 | Pipelined Read Memory System 11-21   |
| Figure 11-13 | Non-Burst Pipelined Read Waveform 11-22  |
| Figure 11-14 | Burst Pipelined Read Waveform 11-23  |
| Figure 11-15 | Pipelined to Non-Pipelined Transitions 11-24   |
| Figure 11-16 | The $\overline{\text{LOCK}}$ Signal 11-27  |
| Figure 11-17 | HOLD/HOLDA Bus Arbitration 11-29   |
| Figure 11-18 | Operation of the Bus Backoff Function 11-31  |
| Figure 11-19 | Example Application of the Bus Backoff Function 11-32                                    |
| Figure 12-1  | Interrupt Controller 12-3  |
| Figure 12-2  | Dedicated Mode 12-4  |
| Figure 12-3  | Expanded Mode 12-5   |
| Figure 12-4  | Implementation of Expanded Mode Sources 12-6   |
| Figure 12-5  | Interrupt Sampling 12-10   |
| Figure 12-6  | Interrupt Control (ICON) Register 12-11  |
| Figure 12-7  | Interrupt Mapping (IMAP0-IMAP2) Registers 12-13  |
| Figure 12-8  | Interrupt Mask (IMSK) and Interrupt Pending (IPND) Registers 12-15                       |
| Figure 12-9  | Calculation of Worst Case Interrupt Latency - $N_{L\_int}$ 12-19                         |
| Figure 13-1  | Source Data Buffering for Destination Synchronized DMAs 13-5                             |
| Figure 13-2  | Example of Source Synchronized Fly-by DMA 13-6   |
| Figure 13-3  | Source Synchronized DMA Loads from an 8-bit, Non-burst, Non-pipelined Memory Region 13-7 |
| Figure 13-4  | Byte to Word Assembly 13-9   |
| Figure 13-5  | Optimization of an Unaligned DMA 13-13   |
| Figure 13-6  | DMA Chaining Operation 13-14   |
| Figure 13-7  | Source Chaining 13-15  |
| Figure 13-8  | Synchronizing to Chained Buffer Transfers 13-17  |
| Figure 13-9  | DMA Command Register (DMAC) 13-22  |
| Figure 13-10 | Setup DMA ( <b>sdma</b> ) Instruction Operands 13-25                                     |
| Figure 13-11 | DMA Control Word 13-26   |
| Figure 13-12 | DMA Data RAM 13-28   |
| Figure 13-13 | DMA External Interface 13-30   |
| Figure 13-14 | DMA Request and Acknowledge Timing 13-32   |



|              |   |       |
|--------------|---|-------|
| Figure 13-15 | $\overline{EOP3:0}$ Timing .....                                  | 13-33 |
| Figure 13-16 | DMA and User Requests in the Bus Queue .....                      | 13-36 |
| Figure 13-17 | DMA Throughput and Latency.....                                   | 13-38 |
| Figure 14-1  | $\overline{FAIL}$ Timing .....                                    | 14-4  |
| Figure 14-2  | Initial Memory Image (IMI) and Process Control Block (PRCB) ..... | 14-6  |
| Figure 14-3  | Process Control Block Configuration Words.....                    | 14-9  |
| Figure 14-4  | Processor Initialization Flow .....                               | 14-13 |
| Figure 14-5  | $V_{CCPLL}$ Lowpass Filter.....                                   | 14-27 |
| Figure 14-6  | Reducing Characteristic Impedance.....                            | 14-28 |
| Figure 14-7  | Series Termination .....  | 14-30 |
| Figure 14-8  | AC Termination.....   | 14-31 |
| Figure 14-9  | Avoid Closed-Loop Signal Paths .....                              | 14-32 |
| Figure A-1   | C-Series Core and Peripherals.....                                | A-1   |
| Figure A-2   | i960 CA/CF Microprocessor Block Diagram .....                     | A-3   |
| Figure A-3   | Instruction Pipeline .....  | A-4   |
| Figure A-4   | Six-Port Register File.....                                       | A-6   |
| Figure A-5   | Data Cache Organization .....                                     | A-8   |
| Figure A-6   | BCU and Data Cache Interaction .....                              | A-11  |
| Figure A-7   | Issue Paths.....  | A-16  |
| Figure A-8   | EU Execution Pipeline .....                                       | A-21  |
| Figure A-9   | MDU Execution Pipeline.....                                       | A-22  |
| Figure A-10  | MDU Pipelined Back-To-Back Operations.....                        | A-23  |
| Figure A-11  | Data RAM Execution Pipeline .....                                 | A-24  |
| Figure A-12  | The <b>Ida</b> Pipeline .....                                     | A-25  |
| Figure A-13  | Back-to-Back BCU Accesses .....                                   | A-28  |
| Figure A-14  | CTRL Pipeline for Branches to Branches.....                       | A-29  |
| Figure A-15  | Branch in First Executable Group.....                             | A-30  |
| Figure A-16  | Branch in Second Executable Group .....                           | A-31  |
| Figure A-17  | Branch in Third Executable Group .....                            | A-32  |
| Figure A-18  | Fetch Execution .....   | A-36  |
| Figure A-19  | Micro-flow Invocation.....  | A-38  |
| Figure B-1   | Non-Pipelined Burst SRAM Interface .....                          | B-2   |
| Figure B-2   | Non-Pipelined SRAM Read Waveform.....                             | B-4   |
| Figure B-3   | Non-Pipelined SRAM Write Waveform .....                           | B-5   |
| Figure B-4   | Chip Enable State Machine .....                                   | B-7   |
| Figure B-5   | A3:2 Address Generation State Machine .....                       | B-8   |
| Figure B-6   | Pipelined Read Address and Data .....                             | B-10  |
| Figure B-7   | Pipelined SRAM Interface Block Diagram .....                      | B-11  |
| Figure B-8   | Pipelined Read Waveform.....                                      | B-13  |
| Figure B-9   | Pipelined Read Chip Enable State Machine.....                     | B-13  |



## CONTENTS

|             |  |
|-------------|--|
| Figure B-10 | Pipelined Read PA3:2 State Machine Diagram B-14                            |
| Figure B-11 | Nibble Mode Read B-16  |
| Figure B-12 | Fast Page Mode DRAM Read B-17  |
| Figure B-13 | Static Column Mode DRAM Read B-18  |
| Figure B-14 | $\overline{\text{RAS}}$ -only DRAM Refresh B-19                            |
| Figure B-15 | $\overline{\text{CAS}}$ -before- $\overline{\text{RAS}}$ DRAM Refresh B-19 |
| Figure B-16 | Address Multiplexer Inputs B-20  |
| Figure B-17 | DRAM System with DMA Refresh B-22  |
| Figure B-18 | DRAM Address Generation State Machine B-23                                 |
| Figure B-19 | DRAM Controller State Machine B-26   |
| Figure B-20 | DMA Request and Acknowledge Signals B-28                                   |
| Figure B-21 | DMA Chaining Description B-29  |
| Figure B-22 | DRAM System Read Waveform B-30   |
| Figure B-23 | DRAM System Write Waveform B-31  |
| Figure B-24 | Memory System Block Diagram B-32   |
| Figure B-25 | DRAM State Machine B-34  |
| Figure B-26 | Two-Way Interleaved Read Access Overlap B-37                               |
| Figure B-27 | Two-Way Interleaved Memory System B-39                                     |
| Figure B-28 | Two-Way Interleaved Read Waveforms B-40                                    |
| Figure B-29 | 8-bit Interface Schematic B-42   |
| Figure B-30 | Read Waveforms B-43  |
| Figure B-31 | Write Waveforms B-44   |
| Figure B-32 | State Machine Diagram B-45   |
| Figure D-1  | Instruction Formats D-2  |
| Figure F-1  | Control Table F-2  |
| Figure F-2  | Fault Record F-3   |
| Figure F-3  | Fault Table and Fault Table Entries F-4                                    |
| Figure F-4  | Initial Memory Image (IMI) and Process Control Block (PRCB) F-5            |
| Figure F-5  | Storage of an Interrupt Record on the Interrupt Stack F-6                  |
| Figure F-6  | Interrupt Table F-7  |
| Figure F-7  | Procedure Stack Structure and Local Registers F-8                          |
| Figure F-8  | System Procedure Table F-9   |
| Figure F-9  | Arithmetic Controls Register (AC) F-10                                     |
| Figure F-10 | Bus Configuration Register (BCON) F-10                                     |
| Figure F-11 | Data Address Breakpoint Registers F-11                                     |
| Figure F-12 | DMA Command Register (DMAC) F-11   |
| Figure F-13 | DMA Control Word F-12  |
| Figure F-14 | Hardware Breakpoint Control Register (BPCON) F-13                          |
| Figure F-15 | Instruction Address Breakpoint Registers (IPB0 - IPB1) F-13                |
| Figure F-16 | Interrupt Control (ICON) Register F-14                                     |



|             |   |      |
|-------------|---|------|
| Figure F-17 | Interrupt Map (IMAP0 - IMAP2) Registers .....                     | F-15 |
| Figure F-18 | Interrupt Mask (IMSK) and Interrupt Pending (IPND) Registers..... | F-16 |
| Figure F-19 | Memory Region Configuration Register (MCON 0-15) .....            | F-17 |
| Figure F-20 | Previous Frame Pointer Register (PFP) (r0).....                   | F-18 |
| Figure F-21 | Process Controls (PC) Register .....                              | F-18 |
| Figure F-22 | Trace Controls (TC) Register .....                                | F-19 |
| Figure F-23 | Process Control Block Configuration Words.....                    | F-20 |

TABLES

Table 1-1 Register Terminology Conventions ..... 1-8

Table 2-1 Registers and Literals Used as Instruction Operands ..... 2-3

Table 2-2 Allowable Register Operands ..... 2-6

Table 2-3 Data Structure Descriptions ..... 2-8

Table 2-4 Alignment of Data Structures in the Address Space ..... 2-11

Table 2-5 Condition Codes for True or False Conditions ..... 2-16

Table 2-6 Condition Codes for Equality and Inequality Conditions ..... 2-16

Table 2-7 Condition Codes for Carry Out and Overflow ..... 2-17

Table 2-8 Supervisor-Only Operations and Faults Generated in User Mode ..... 2-21

Table 3-1 Supported Integer Sizes ..... 3-2

Table 3-2 Supported Ordinal Sizes ..... 3-3

Table 3-3 Memory Contents For Little and Big Endian Example ..... 3-5

Table 3-4 Byte Ordering for Little and Big Endian Accesses ..... 3-5

Table 3-5 Memory Addressing Modes ..... 3-6

Table 4-1 i960<sup>®</sup> Cx Microprocessor Instruction Set Summary ..... 4-4

Table 4-2 Arithmetic Operations ..... 4-7

Table 4-3 System Control Message Types and Operand Fields ..... 4-20

Table 4-4 Cache Configuration Modes ..... 4-22

Table 4-5 Control Register Table and Register Group Numbers ..... 4-24

Table 5-1 PRCB Cache Configuration Word and Internal Data RAM ..... 5-9

Table 5-2 Encodings of Entry Type Field in System Procedure Table ..... 5-14

Table 5-3 Encoding of Return Status Field ..... 5-17

Table 7-1 i960<sup>®</sup> Cx Processor Fault Types and Subtypes ..... 7-3

Table 7-2 Fault Flags or Masks ..... 7-15

Table 9-1 Abbreviations in Pseudo-code ..... 9-5

Table 9-2 Pseudo-code Symbol Definitions ..... 9-6

Table 9-3 Fault Types and Subtypes ..... 9-6

Table 9-4 Common Possible Faulting Conditions ..... 9-7

Table 9-5 Cache Configuration Modes ..... 9-79

Table 10-1 MCON0-15 Programmable Bits ..... 10-8

Table 10-2 BCON Register Bit Definitions ..... 10-9

Table 11-1 Bus Controller Pins ..... 11-3

Table 11-2 Byte Enable Encoding ..... 11-11

Table 11-3 Burst Transfers and Bus Widths ..... 11-15

Table 11-4 Byte Ordering on Bus Transfers ..... 11-26

Table 12-1 Location of Cached Vectors in Internal RAM ..... 12-20

Table 12-2 Cache Configuration Modes ..... 12-22

Table 13-1 Transfer Type Options ..... 13-4

Table 13-2 DMA Configuration and Byte Count Alignment ..... 13-10



Table 13-3 DMA Transfer Alignment Requirements 13-11

Table 13-4 Rotating Channel Priority 13-20

Table 13-5 DMA Transfer Clocks -  $N_{XFER}$  13-39

Table 13-6 Base Values of Worst-case DMA Throughput used for DMA Latency Calculation 13-42

Table 13-7 DMA Latency Components 13-43

Table 13-8 Values of DMA Latency Components 13-43

Table 14-1 Pin Reset State 14-3

Table 14-2 Register Values After Reset 14-3

Table 14-3 i960<sup>®</sup> Cx Processor Input Pins 14-29

Table A-1 BCU Instructions for the i960 CF Processor A-12

Table A-2 Machine Type Sequences Which Can Be Issued In Parallel A-16

Table 1-3 Scoreboarded Register Conditions A-18

Table A-4 Scoreboarded Resource Conditions A-19

Table A-5 Scoreboarded Resource Conditions Due to the Data Cache A-20

Table A-6 EU Instructions A-21

Table A-7 MDU Instructions A-23

Table A-8 Data RAM Instructions A-24

Table A-9 AGU Instructions A-25

Table A-10 BCU Instructions for the i960 CA Processor A-27

Table A-11 CTRL Instructions A-29

Table A-12 Cache Configuration Modes A-34

Table A-13 Fetch Strategy A-34

Table A-15 Store Micro-flow Instruction Issue Clocks A-39

Table A-14 Load Micro-flow Instruction Issue Clocks A-39

Table A-16 Bit and Bit Field Micro-flow Instructions A-40

Table A-17 **bx** and **balx** Performance A-40

Table A-18 **callx** Performance A-41

Table A-19 **sysctl** Performance A-43

Table A-20 Creative Uses for the **lda** Instruction A-49

Table A-21 Code Optimization Summary A-57

Table D-1 Encoding of SRC/DST Field in REG Format D-2

Table D-2 Addressing Modes for MEM Format Instructions D-4

Table D-3 Encoding of Scale Field D-5

Table E-1 Miscellaneous Instruction Encoding Bits E-1

Table E-2 REG Format Instruction Encodings E-2

Table E-3 COBR Format Instruction Encodings E-4

Table E-4 CTRL Format Instruction Encodings E-5

Table E-5 MEM Format Instruction Encodings E-6









# 1

## INTRODUCTION





The i960<sup>®</sup> CA and CF superscalar microprocessors represent Intel's commitment to provide a spectrum of reliable, cost-effective, high-performance processors that satisfy the requirements of today's innovative microprocessor-based products. The i960 Cx<sup>1</sup> processors are designed for applications which require greater performance on a single chip than is usually found in an entire embedded system. The sheer speed of the i960 Cx processors enriches traditional embedded applications and makes many new functions possible at a reduced cost. These embedded processors are versatile; they are found in diverse products such as laser printers, X-terminals, bridges, routers, PC add-in cards and server motherboards.

Figure 1-1 identifies the processors' most notable features, including the multiple-instruction per clock C-series core, two-way set associative instruction cache, programmable register cache, on-chip data RAM, multi-mode programmable bus controller for its demultiplexed bus, four-channel 59 Mbyte per second DMA controller and high-speed interrupt controller.

## 1.1 i960<sup>®</sup> MICROPROCESSOR ARCHITECTURE

The i960 architecture provides a high-performance computing model. The architecture profits from reduced instruction set computer (RISC) concepts and — through superscalar implementations — includes refinements for execution of more than one instruction per clock. The architecture provides a high-speed procedure call/return model, a powerful instruction set suited to parallelism and integrated interrupt- and fault-handling models appropriate in a parallel execution environment.

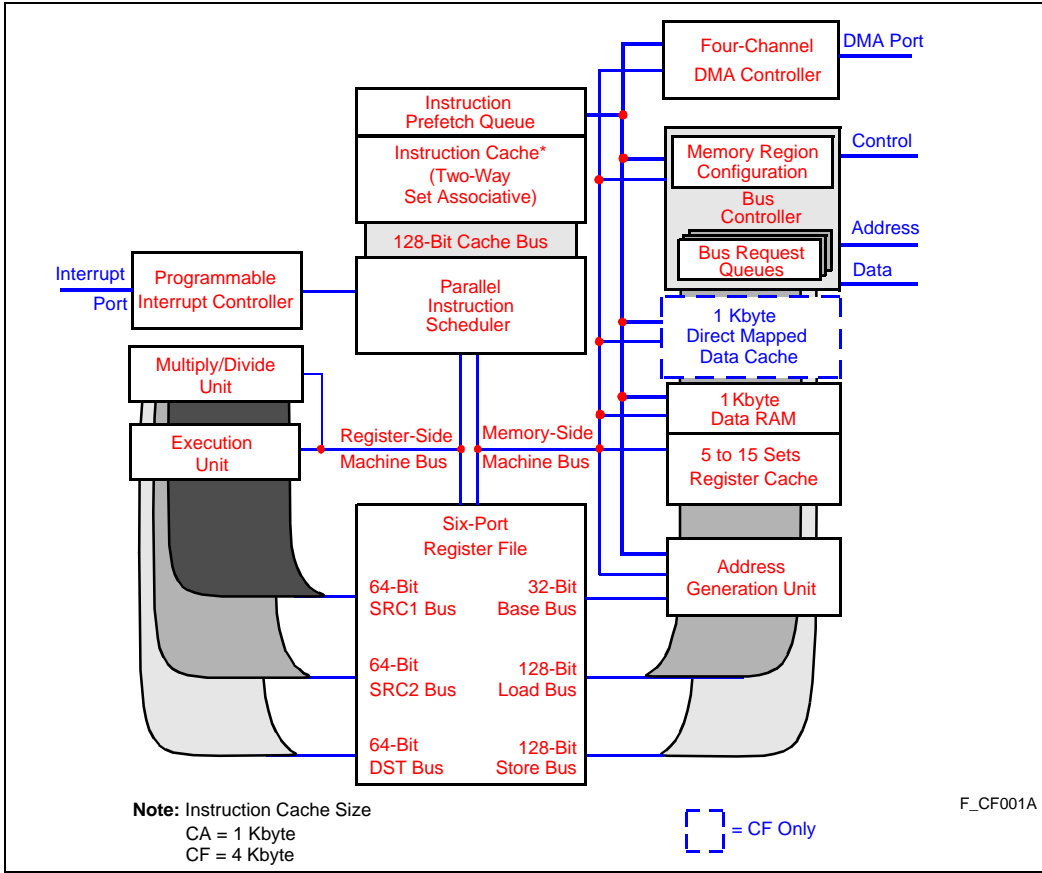
### 1.1.1 Parallel Instruction Execution

To sustain execution of multiple instructions in each clock cycle, a processor must decode multiple instructions in parallel and simultaneously issue these instructions to parallel processing units. The various processing units must then be able to independently access instruction operands in parallel from a common register set.

The on-chip instruction cache enables parallel decode by constantly providing the next four unexecuted instructions to the processor's instruction scheduler. In a single clock cycle, the scheduler inspects all four instructions and issues one, two or three of these instructions in the same clock cycle.

---

1. Throughout this manual, "Cx" refers to both the i960 CA and CF microprocessors. Information that is specific to each is clearly indicated.



**Figure 1-1. i960® CA/CF Superscalar Microprocessor Architecture**

Parallel decode also speeds conditional operations such as branches. These instructions are decoded and executed ahead of the current instruction pointer while maintaining the logical control flow of the sequential program.

Once the scheduler issues an instruction or group of instructions, one of six parallel processing units begins to execute each instruction. Each parallel unit handles a different subset of the instruction set, enabling multiple instructions to be issued and executed every clock cycle. Each unit executes its instructions in parallel with other processor operations.

The i960 Cx processors' 32 general-purpose 32-bit registers are each six-ported to allow unimpeded parallel access to independent processing units. To maintain the logical integrity of sequential instructions which are being executed in parallel, the processor implements register scoreboarding and resource scoreboarding interlocks.



The superscalar i960 Cx processors can decode multiple instructions at once and issue them to independent processing units where they are executed in parallel. As a result, the processors deliver sustained execution of multiple instructions per clock from a sequential instruction stream.

### 1.1.2 Full Procedure Call Model

These processors support two types of procedure calls: an integrated call-and-return mechanism and a RISC-style branch-and-link instruction. The integrated call-and-return mechanism automatically saves local registers when a **call** instruction executes and restores them when a **ret** (return) instruction executes. The RISC-style branch-and-link is a fast call that does not save any of the registers. These mechanisms result in high performance and reduced code size, while maintaining assembly-level compatibility.

To attain the highest performance for procedure calls and returns, the processors integrate a programmable depth register cache. The register cache internally saves the local registers for procedure calls, rather than actually writing the data to the external procedure stack. This caching greatly reduces the external bus traffic associated with procedure context saving and restoring.

### 1.1.3 Versatile Instruction Set and Addressing

The i960 Cx microprocessors offer a full set of load, store, move, arithmetic, shift, comparison and branch instructions and support operations on both integer and ordinal data types. They also provide a complete set of Boolean and bit-field instructions to simplify manipulation of bits and bit strings.

Most instructions are typical RISC operations. However, several commonly used complex instructions are also part of the instruction set. Performance is optimized by implementing these commonly used functions with parallel hardware. For instance, the 32x32 multiply operation — a single instruction — takes less than five clocks to execute: 150 ns or less at 33 MHz. Furthermore, the multiplier is a parallel unit; this allows instructions that follow a multiply to execute before the multiplication is complete. In fact, if several unrelated instructions follow a multiply, the multiplication consumes only one clock of execution.

### 1.1.4 Integrated Priority Interrupt Model

The i960 Cx microprocessors provide a priority-based mechanism for servicing interrupts. The mechanism transparently manages up to 248 distinct sources with 31 levels of priority. Interrupt requests may be generated from external hardware, internal hardware or software.

The interrupt mechanism is managed by hardware which operates in parallel with program execution. This reduces interrupt latency and overhead and provides flexible interrupt handling control.

## INTRODUCTION

### 1.1.5 Complete Fault Handling and Debug Capabilities

To aid in program development, the i960 Cx processors detect faults (exceptions). When a fault is detected, the processors make an implicit call to a fault handling routine. Information collected for each fault allows a program developer to quickly correct faulting code. The processors also allow automatic recovery from most faults.

To support system debug, the i960 architecture provides a mechanism for monitoring processor activities through a software tracing facility. The i960 Cx processors can be configured to detect as many as seven different trace events, including breakpoints, branches, calls, supervisor calls, returns, prereturns and the execution of each instruction (for single-stepping through a program). The processors also provide four breakpoint registers that allow break decisions to be made based upon instruction or data addresses.

## 1.2 SYSTEM INTEGRATION

The i960 Cx microprocessors are based on the C-series core, which is object code compatible with the 32-bit i960 microprocessor core architecture. Additionally, the i960 Cx devices integrate three peripherals around the core: bus control unit, DMA controller and interrupt controller.

### 1.2.1 Pipelined Burst Bus Control Unit

The i960 Cx processors integrate a 32-bit high-performance bus controller for interfacing to external memory and peripherals. The bus control unit incorporates full wait state logic and bus width control to provide high system performance with minimal system design complexity. The bus control unit features a maximum transfer rate of 132 Mbytes per second (at 33 MHz). Internally programmable wait states and 16 separately configurable memory regions allow the processor to interface with a variety of memory subsystems with minimum complexity and maximum performance.

### 1.2.2 Flexible DMA Controller

A four-channel DMA controller provides high-speed DMA data transfers. Source and destination can be any combination of internal RAM, external memory or peripherals. DMA channels perform single-cycle or multi-cycle transfers and can perform data packing and unpacking between peripherals and memory with varying bus widths. Also provided are block transfers, in addition to source- or destination-synchronized transfers.

The DMA supports various transfer types such as high speed fly-by, quad-word transfers and data chaining with the use of linked descriptor lists. The high performance fly-by mode is capable of transfer speeds of up to 59 Mbytes per second at 33 MHz.



### 1.2.3 Priority Interrupt Controller

1

The interrupt controller provides full programmability of 248 interrupt sources into 31 priority levels. The interrupt controller handles prioritization of software interrupts, hardware interrupts and process priority. In addition, it also manages four internal sources from the DMA controller and a single non-maskable interrupt input.

## 1.3 ABOUT THIS MANUAL

This *i960® CA/CF Microprocessor User's Manual* provides detailed programming and hardware design information for the i960 Cx microprocessors. It is written for programmers and hardware designers who understand the basic operating principles of microprocessors and their systems.

This manual does not provide electrical specifications such as DC and AC parametrics, operating conditions and packaging specifications. Such information is found in the 80960CA/CF microprocessor data sheets (80960CA order number is 270727; 80960CF is 272187). To obtain updates and errata, call Intel's FaxBack data-on-demand system (1-800-628-2283 or 916-356-3105).

For information on other i960 processor family products or the architecture in general, refer to Intel's *Solutions960®* catalog (order number is 270791). It lists all current i960 microprocessor family-related documents, support components, boards, software development tools, debug tools and more. Other information can be obtained from Intel's technical BBS (916-356-3600).

This manual is organized in three parts; each part comprises multiple chapters and/or appendices. The following briefly describes each part:

- *Part I - Programming the i960 Cx Microprocessor* (Chapters 2-9) details the programming environment for the i960 Cx devices. Described here are the processor's registers, instruction set, data types, addressing modes, interrupt mechanism, external interrupt interface and fault mechanism.
- *Part II - System Implementation* (Chapters 10-14) identifies requirements for designing a system around the i960 Cx components, such as external bus interface, interrupt controller and integrated DMA controller. Also described are programming requirements for the DMA controller, bus controller and processor initialization.
- *Part III - Appendices* includes quick references for hardware design and programming. Appendices are also provided which describe the internal architecture, how to write assembly-level code to exploit the parallelism of the processor and considerations for writing software which is portable among all members of the i960 microprocessor family.

## INTRODUCTION

### 1.4 NOTATION AND TERMINOLOGY

This section defines terminology and textual conventions that are used throughout the manual.

#### 1.4.1 Reserved and Preserved

Certain fields in registers and data structures are described as being either *reserved* or *preserved*:

- A reserved field is one that may be used by other i960 architecture implementations. Correct treatment of reserved fields ensures software compatibility with other i960 processors. The processor uses these fields for temporary storage; as a result, the fields sometimes contain unusual values.
- A preserved field is one that the processor does not use. Software may use preserved fields for any function.

Reserved fields in certain data structures should be set to 0 (zero) when the data structure is created. Set reserved fields to 0 when creating the Control Table, Initialization Boot Record, Interrupt Table, Fault Table, System Procedure Table and Process Control Block. Software should not modify or rely on these reserved field values after a data structure is created. When the processor creates the Interrupt or Fault Record data structure on the stack, software should not depend on the value of the reserved fields within these data structures.

Some bits or fields in data structures and registers are shown as requiring specific encoding. These fields should be treated as if they were reserved fields. They should be set to the specified value when the data structure is created or when the register is initialized and software should not modify or rely on the value after that.

Reserved bits in the Special Function Registers and Arithmetic Controls (AC) register can be set to 0 after initialization to ensure compatibility with future implementations. Reserved bits in the Process Controls (PC) register and Trace Controls (TC) register should not be initialized.

When the AC, PC and TC registers are modified using **modac**, **modpc** or **modtc** instructions, the reserved locations in these registers must be masked.

Certain areas of memory may be referred to as *reserved memory* in this reference manual. Reserved — when referring to memory locations — implies that an implementation of the i960 architecture may use this memory for some special purpose. For example, memory-mapped peripherals would be located in reserved memory areas on future implementations. Programs may use reserved memory just like any other memory unless it is specifically documented otherwise. The i960 Cx processors' Initialization Boot Record must be located in reserved memory at address FFFF FF00H. System designers typically map the entire boot ROM into the reserved memory to reduce the complexity of the select decoding.





### 1.4.2 Specifying Bit and Signal Values

The terms *set* and *clear* in this manual refer to bit values in register and data structures. If a bit is set, its value is 1; if the bit is clear, its value is 0. Likewise, setting a bit means giving it a value of 1 and clearing a bit means giving it a value of 0.

The terms *assert* and *deassert* refer to the logically active or inactive value of a signal or bit, respectively. A signal is specified as an active 0 signal by an overbar. For example, the input is active low and is asserted by driving the signal to a logic 0 value.

### 1.4.3 Representing Numbers

All numbers in this manual can be assumed to be base 10 unless designated otherwise. In text, binary numbers are sometimes designated with a subscript 2 (for example,  $001_2$ ). If it is obvious from the context that a number is a binary number, the “2” subscript may be omitted.

Hexadecimal numbers are designated in text with the suffix H (for example, FFFF FF5AH). In pseudo-code action statements in the instruction reference section and occasionally in text, hexadecimal numbers are represented by adding the C-language convention “0x” as a prefix. For example “FF7AH” appears as “0xFF7A” in the pseudo-code.

### 1.4.4 Register Names

Special function registers and several of the global and local registers are referred to by their generic register names, as well as descriptive names which describe their function. The global register numbers are g0 through g15; local register numbers are r0 through r15; special function registers are sf0, sf1 and sf2. However, when programming the registers in user-generated code, make sure to use the *instruction operand*. i960 microprocessor compilers recognize only the instruction operands listed in Table 1-1. Throughout this manual, the registers’ descriptive names, numbers, operands and acronyms are used interchangeably, as dictated by context.

Groups of bits and single bits in registers and control words are called either *bits*, *flags* or *fields*. These terms have a distinct meaning in this manual:

|       |  |
|-------|--|
| bit   | Controls a processor function; programmed by the user.                                 |
| flag  | Indicates status. Generally set by the processor; certain flags are user programmable. |
| field | A grouping of bits (bit field) or flags (flag field).                                  |

Table 1-1. Register Terminology Conventions

| Register Descriptive Name         | Register Number | Instruction Operand | Acronym |
|-----------------------------------|-----------------|---------------------|---------|
| Global Registers                  | g0 - g15        | g0 - g14            |         |
| <i>Frame Pointer</i>              | g15             | fp                  | FP      |
| Local Registers                   | r0 - r15        | r3 - r15            |         |
| <i>Previous Frame Pointer</i>     | r0              | pfp                 | PFP     |
| <i>Stack Pointer</i>              | r1              | sp                  | SP      |
| <i>Return Instruction Pointer</i> | r2              | rip                 | RIP     |
| Interrupt Pending Register        | sf0             | sf0                 | IPND    |
| Interrupt Mask Register           | sf1             | sf1                 | IMSK    |
| DMA Command Register              | sf2             | sf2                 | DMAC    |

Specific bits, flags and fields in registers and control words are usually referred to by a register abbreviation (in upper case) followed by a bit, flag or field name (in lower case). These items are separated with a period. A position number designates individual bits in a field. For example, the return type (rt) field in the previous frame pointer (PFP) register is designated as “PFP.rt”. The least significant bit of the return type field is then designated as “PFP.rt0”.





2

# PROGRAMMING ENVIRONMENT

|



# CHAPTER 2 PROGRAMMING ENVIRONMENT

This chapter describes the i960® Cx microprocessors' programming environment including global and local registers, special function registers, control registers, literals, processor-state registers and address space.

## 2.1 OVERVIEW

The i960 architecture defines a programming environment for program execution, data storage and data manipulation. Figure 2-1 shows the programming environment elements which include a 4 Gbyte ( $2^{32}$  byte) flat address space, an instruction cache, global and local general-purpose registers, a set of literals, special function registers, control registers and a set of processor state registers. A register cache saves the 16 procedure-specific local registers.

The processor defines several data structures located in memory as part of the programming environment. These data structures handle procedure calls, interrupts and faults and provide configuration information at initialization. These data structures are:

- interrupt stack
- local stack
- supervisor stack
- control table
- fault table
- interrupt table
- system procedure table
- process control block
- initialization boot record

## 2.2 REGISTERS AND LITERALS AS INSTRUCTION OPERANDS

The i960 Cx processors use only simple load and store instructions to access memory; all operations take place at the register level. The processors use 16 global registers, 16 local registers, three special function registers and 32 literals (constants 0-31) as instruction operands.

The global register numbers are g0 through g15; local register numbers are r0 through r15; special function registers are sf0, sf1 and sf2. Several of these registers are used for a dedicated function. For example, register r0 is the previous frame pointer, sometimes referred to as pfp. Some assemblers and compilers only recognize one form of a register operand. i960 processor compilers recognize only the instruction operands listed in Table 2-1. Throughout this manual, the registers' descriptive names, numbers, operands and acronyms are used interchangeably, as dictated by context.

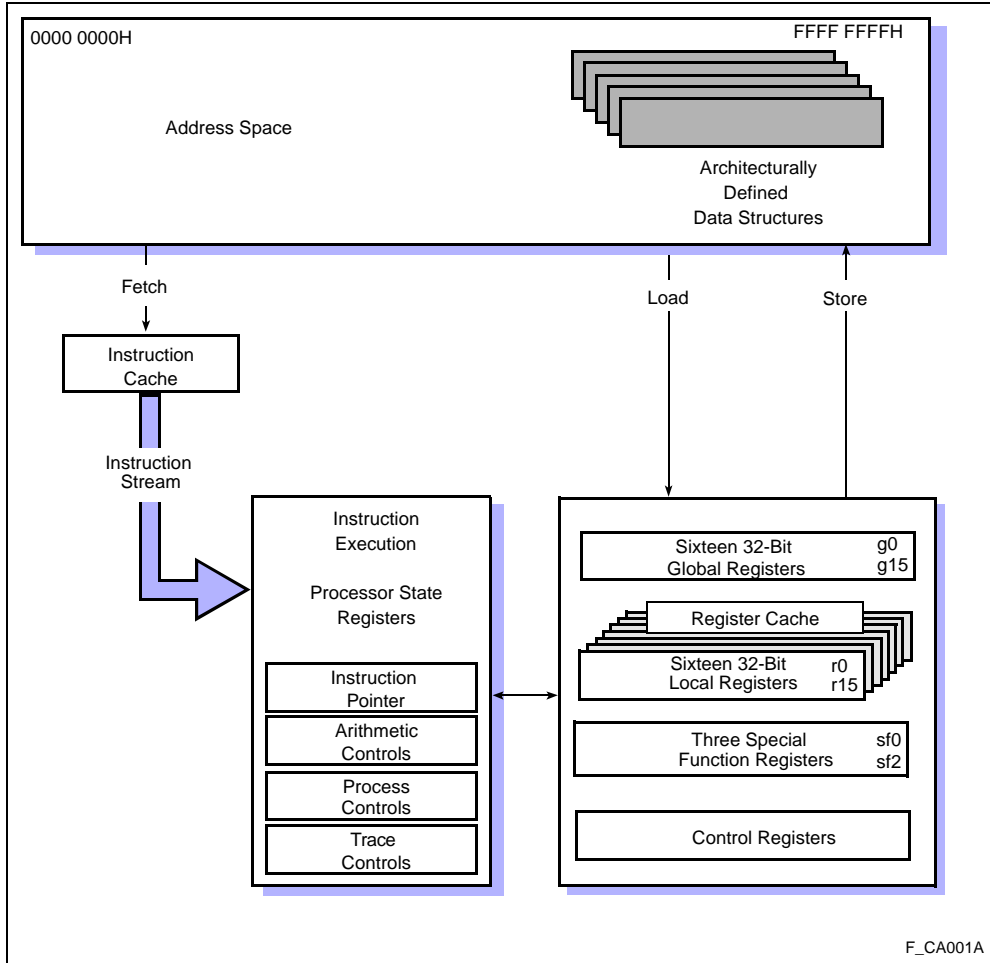


Figure 2-1. i960 Cx Microprocessor Programming Environment

### 2.2.1 Global Registers

Global registers are general-purpose 32-bit data registers that provide temporary storage for a program's computational operands. These registers retain their contents across procedure boundaries. As such, they provide a fast and efficient means of passing parameters between procedures.



Table 2-1. Registers and Literals Used as Instruction Operands

| Instruction Operand | Register Name (number) | Function                   | Acronym |
|---------------------|------------------------|----------------------------|---------|
| g0 - g14            | global (g0-g14)        | general purpose            |         |
| fp                  | global (g15)           | frame pointer              | FP      |
| pfp                 | local (r0)             | previous frame pointer     | PFP     |
| sp                  | local (r1)             | stack pointer              | SP      |
| rip                 | local (r2)             | return instruction pointer | RIP     |
| r3 - r15            | local (r3-r15)         | general purpose            |         |
| sf0                 | special function 0     | interrupt pending          | IPND    |
| sf1                 | special function 1     | interrupt mask             | IMSK    |
| sf2                 | special function 2     | DMA command                | DMAC    |
| 0-31                |                        | literals                   |         |

The i960 architecture supplies 16 global registers, designated g0 through g15. Register g15 is reserved for the current Frame Pointer (FP) which contains the address of the first byte in the current (topmost) stack frame. See section 5.2, “CALL AND RETURN MECHANISM” (pg. 5-2) for a description of the FP and procedure stack.

After the processor is reset, register g0 contains die stepping information. Software must read the value of g0 before any action is taken to modify this register. The Stepping Register Information section in the 80960CA and CF data sheets describes the die stepping information contained in g0.

### 2.2.2 Local Registers

The i960 architecture provides a separate set of 32-bit local data registers (r0 through r15) for each active procedure. These registers provide storage for variables that are local to a procedure. Each time a procedure is called, the processor allocates a new set of local registers for that procedure and saves the calling procedure’s local registers on the procedure stack. The processor performs local register management; a program need not explicitly save and restore these registers.

r3 through r15 are general purpose registers; r0 through r2 are reserved for special functions: r0 contains the Previous Frame Pointer (PFP); r1 contains the Stack Pointer (SP); r2 contains the Return Instruction Pointer (RIP). These are discussed in CHAPTER 5, PROCEDURE CALLS.

#### NOTE:

The processor does not always clear or initialize the set of local registers assigned to a new procedure. Therefore, initial register contents are unpredictable. Also, because the processor does not initialize the local register save area in the newly created stack frame for the procedure, its contents are equally unpredictable.

### 2.2.3 Special Function Registers (SFRs)

The i960 architecture provides a mechanism to expand its architecture-defined register set with up to 32 additional 32-bit registers. On the i960 Cx microprocessor, three special function registers (SFRs) are provided as an extension to the architectural register model. These registers are designated sf0, sf1, sf2 (see Table 2-1). Registers sf3 – sf31 are not implemented on the i960 Cx processors. Reading or modifying unimplemented registers causes the operation-invalid-opcode fault to occur. SFRs provide a means to configure and monitor the interrupt controller and DMA controller status; for the i960 CF processor, SFRs are used to control the data cache.

The processor provides a mechanism which allows only privileged access to SFRs. These registers can only be accessed while the processor is in supervisor execution mode. See section 2.7, “USER SUPERVISOR PROTECTION MODEL” (pg. 2-20). A type-mismatch fault occurs if an instruction with a SFR operand is executed in user mode.

SFRs are not used as operands for instructions whose machine-level instruction format is of type MEM or CTRL. Such instructions include loads, stores and those which cause program redirection (call, return and branches). APPENDIX D, MACHINE-LEVEL INSTRUCTION FORMATS describes machine-level encoding for operands. Table 2-2 summarizes the use of SFRs as instruction operands.

### 2.2.4 Register Scoreboarding

Register scoreboarding allows concurrent execution of sequential instructions. When an instruction executes, the processor sets a register-scoreboard bit to indicate that a particular register or group of registers is being used in an operation. If the instructions that follow do not target registers already in use, the processor can execute those instructions before the prior instruction execution completes.

A common application of this feature is to execute one or more single-cycle instructions concurrently with a multi-cycle instruction (e.g., multiply or divide). Example 2-1 shows a case where register scoreboarding prevents a subsequent instruction from executing. It also illustrates overlapping instructions which do not have register dependencies.

Register scoreboarding is implemented for global and local registers but not for SFRs. When a SFR is the destination of a multi-cycle instruction, the programmer must prevent access to the SFR until the multi-clock instruction returns a result to the SFR.





**Example 2-1. Register Scoreboarding**

```

multi  r4,r5,r6          # r6 is scoreboardd
addi   r6,r7,r8          # add must wait for the previous multiply
      .                  # to complete
      .
      .
multi  r4,r5,r10         # r10 is scoreboardd; and instruction
and    r6,r7,r8          # is executed concurrently with multiply

```

2

**2.2.5 Literals**

The architecture defines a set of 32 literals which can be used as operands in many instructions. These literals are ordinal (unsigned) values that range from 0 to 31 (5 bits). When a literal is used as an operand, the processor expands it to 32 bits by adding leading zeros. If the instruction requires an operand larger than 32 bits, the processor zero-extends the value to the operand size. If a literal is used in an instruction that requires integer operands, the processor treats the literal as a positive integer value.

**2.2.6 Register and Literal Addressing and Alignment**

Several instructions operate on multiple-word operands. For example, the load long instruction (**ldl**) loads two words from memory into two consecutive registers. The register for the less-significant word is specified in the instruction; the more-significant word is automatically loaded into the next higher-numbered register.

In cases where an instruction specifies a register number and multiple, consecutive registers are implied, the register number must be even if two registers are accessed (e.g., g0, g2) and an integral multiple of 4 if three or four registers are accessed (e.g., g0, g4). If a register reference for a source value is not properly aligned, the source value is undefined and an operation-invalid-operand fault is generated. If a register reference for a destination value is not properly aligned, the registers to which the processor writes and the values written are undefined. The processor then generates an operation-invalid-operand fault. The assembly language code in Example 2-2 shows an example of correct and incorrect register alignment.

**Example 2-2. Register Alignment**

```

movl   g3,g8             # INCORRECT ALIGNMENT - resulting value
      .                  # in registers g8 and g9 is
      .                  # unpredictable (non-aligned source)
      .
movl   g4,g8             # CORRECT ALIGNMENT

```

Global registers, local registers, special function registers and literals are used directly as instruction operands. Table 2-2 lists instruction operands for each machine level instruction format and positions which can be filled by each register or literal.

**Table 2-2. Allowable Register Operands**

| Instruction Encoding | Operand Field            | Operand (1)    |                 |                         |         |
|----------------------|--------------------------|----------------|-----------------|-------------------------|---------|
|                      |                          | Local Register | Global Register | Extended Register (SFR) | Literal |
| <b>REG</b>           | <i>src1</i>              | X              | X               | X                       | X       |
|                      | <i>src2</i>              | X              | X               | X                       | X       |
|                      | <i>src/DST (as src)</i>  | X              | X               |                         | X       |
|                      | <i>src/DST (as DST)</i>  | X              | X               | X                       |         |
|                      | <i>src/DST (as both)</i> | X              | X               | (2)                     |         |
| <b>MEM</b>           | <i>src/DST</i>           | X              | X               |                         |         |
|                      | <i>abase</i>             | X              | X               |                         |         |
|                      | <i>index</i>             | X              | X               |                         |         |
| <b>COBR</b>          | <i>src1</i>              | X              | X               |                         |         |
|                      | <i>src2</i>              | X              | X               | X                       |         |
|                      | <i>DST</i>               | X (3)          | X (3)           | X (3)                   |         |

**NOTES:**

1. "X" denotes the register can be used as an operand in a particular instruction field.
2. Extended registers cannot be addressed in the *src/DST* field of **REG** format instructions in which this field is used as both source and destination (e.g., **extract** and **modify**).
3. The **COBR** destination operands apply only to **TEST** instructions.

**2.3 CONTROL REGISTERS**

Control registers are used to configure on-chip peripherals: DMA controller, interrupt controller and bus controller. A program cannot access control registers directly as instruction operands. Instead, control registers are loaded from a data structure called the control table (see Figure 2-2).

The system control (**sysctl**) instruction moves control table values to on-chip control registers. The control table comprises seven quad-word groups; each group is assigned a group number from zero to six. When **sysctl** executes, the load control register message type and group number are specified. **sysctl** moves the quad-word group of register values from the control table in memory and writes the values to on-chip registers. See section 4.3, "SYSTEM CONTROL FUNCTIONS" (pg. 4-19).

At initialization, the control table is automatically loaded into the on-chip control registers. This action simplifies the user's startup code by providing a transparent setup of the processor's peripherals at initialization. See CHAPTER 14, INITIALIZATION AND SYSTEM REQUIREMENTS.



|    |   |          |
|----|---|----------|
| 31 |   | 0        |
|    | IP Breakpoint 0 (IPB0)                  | 00H      |
|    | IP Breakpoint 1 (IPB1)                  | 04H      |
|    | Data Address Breakpoint 0 (DAB0)        | 08H      |
|    | Data Address Breakpoint 1 (DAB1)        | 0CH      |
|    | Interrupt Map 0 (IMAP0)                 | 10H      |
|    | Interrupt Map 1 (IMAP1)                 | 14H      |
|    | Interrupt Map 2 (IMAP2)                 | 18H      |
|    | Interrupt Control (ICON)                | 1CH      |
|    | Memory Region 0 Configuration (MCON0)   | 20H      |
|    | Memory Region 1 Configuration (MCON1)   | 24H      |
|    | Memory Region 2 Configuration (MCON2)   | 28H      |
|    | Memory Region 3 Configuration (MCON3)   | 2CH      |
|    | Memory Region 4 Configuration (MCON4)   | 30H      |
|    | Memory Region 5 Configuration (MCON5)   | 34H      |
|    | Memory Region 6 Configuration (MCON6)   | 38H      |
|    | Memory Region 7 Configuration (MCON7)   | 3CH      |
|    | Memory Region 8 Configuration (MCON8)   | 40H      |
|    | Memory Region 9 Configuration (MCON9)   | 44H      |
|    | Memory Region 10 Configuration (MCON10) | 48H      |
|    | Memory Region 11 Configuration (MCON11) | 4CH      |
|    | Memory Region 12 Configuration (MCON12) | 50H      |
|    | Memory Region 13 Configuration (MCON13) | 54H      |
|    | Memory Region 14 Configuration (MCON14) | 58H      |
|    | Memory Region 15 Configuration (MCON15) | 5CH      |
|    | Reserved (Initialize to 0)              | 60H      |
|    | Breakpoint Control (BPCON)              | 64H      |
|    | Trace Controls (TC)                     | 68H      |
|    | Bus Configuration Control (BCON)        | 6CH      |
|    |   | F_CA002A |

2

Figure 2-2. Control Table

2.4 ARCHITECTURE-DEFINED DATA STRUCTURES

The architecture defines a set of data structures including stacks, interfaces to system procedures, interrupt handling procedures and fault handling procedures. Table 2-3 defines the data structures and references other sections of this manual where detailed information can be found.

Table 2-3. Data Structure Descriptions

| Structure (see also)  | Description  |
|---|--|
| <b>user stack</b><br>section 5.6, "USER AND SUPERVISOR STACKS" (pg. 5-15)   | The processor uses this stack when executing application code.   |
| <b>system procedure table</b><br>section 2.7, "USER SUPERVISOR PROTECTION MODEL" (pg. 2-20)<br>section 5.5, "SYSTEM CALLS" (pg. 5-12) | Contains pointers to system procedures. Application code uses the system call instruction ( <b>calls</b> ) to access system procedures through this table. A specific type of system call — a system supervisor call — switches execution mode from user mode to supervisor mode. When the processor switches to supervisor mode, it also switches to a new stack: the supervisor stack.   |
| <b>interrupt table</b><br>section 6.4, "INTERRUPT TABLE" (pg. 6-3)  | Contains vectors (pointers) to interrupt handling procedures. When an interrupt is serviced, a particular interrupt table entry is specified. A separate interrupt stack is provided to ensure that interrupt handling does not interfere with application programs.   |
| <b>fault table</b><br>section 7.3, "FAULT TABLE" (pg. 7-4)  | Contains pointers to fault handling procedures. When the processor detects a fault, the processor selects a particular entry in the fault table. The architecture does not require a separate fault handling stack. Instead, a fault handling procedure uses the supervisor stack, user stack or interrupt stack, depending on processor execution mode when the fault occurred and type of call made to the fault handling procedure. |
| <b>control table</b><br>section 2.3, "CONTROL REGISTERS" (pg. 2-6)<br>section 4.3, "SYSTEM CONTROL FUNCTIONS" (pg. 4-19)              | Contains on-chip control register values. Control table values are moved to on-chip registers at initialization or with <b>sysctl</b> .  |

The i960 Cx processors define two initialization data structures: initialization boot record (IBR) and processor control block (PRCB). These structures provide initialization data and pointers to other data structures in memory. When the processor is initialized, these pointers are read from the initialization data structures and cached for internal use.

Pointers to the system procedure table, interrupt table, interrupt stack, fault table and control table are specified in the processor control block. Supervisor stack location is specified in the system procedure table. User stack location is specified in the user's startup code. Of these structures, the system procedure table, fault table, control table and initialization data structures may be in ROM; the interrupt table and stacks must be in RAM. The interrupt table must be in RAM because the processor sometimes writes to it.



## 2.5 MEMORY ADDRESS SPACE

Address space is byte-addressable with addresses running contiguously from 0 to  $2^{32}-1$ . Some of this address space is reserved or assigned special functions as shown in Figure 2-3.

2

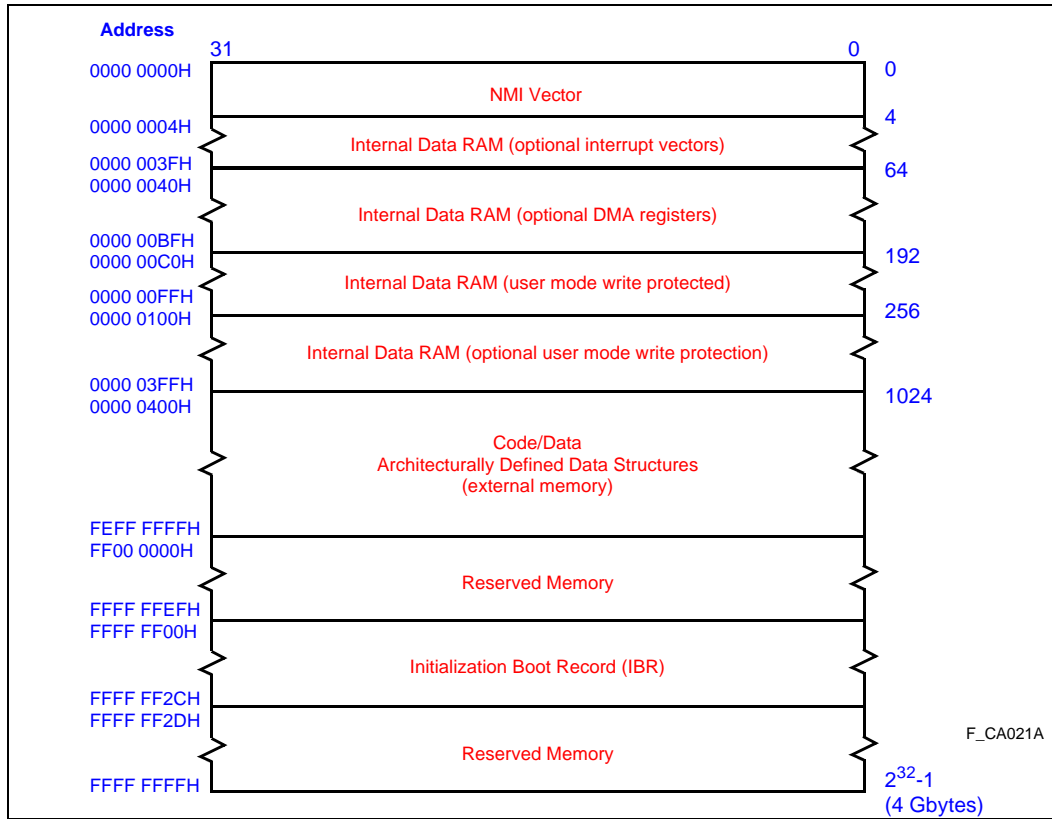


Figure 2-3. Address Space

Address space can be mapped to read-write memory, read-only memory and memory-mapped I/O. The architecture does not define a dedicated, addressable I/O space. There are no subdivisions of the address space such as segments. For memory management, an external memory management unit (MMU) may subdivide memory into pages or restrict access to certain areas of memory to protect a kernel's code, data and stack. However, the processor views this address space as linear.

An address in memory is a 32-bit value in the range 0H to FFFF FFFFH. Depending on the instruction, an address can reference in memory a single byte, half-word (2 bytes), word (4 bytes), double-word (8 bytes), triple-word (12 bytes) or quad-word (16 bytes). Refer to load and store instruction descriptions in CHAPTER 9, INSTRUCTION SET REFERENCE for multiple-byte addressing information.



### 2.5.1 Memory Requirements

The architecture requires that external memory has the following properties:

- Memory must be byte-addressable.
- Memory must support burst transfers (i.e., transfer blocks of up to 16 contiguous bytes).
- No memory is mapped at reserved addresses which are specifically used by an implementation.
- Memory must guarantee indivisible access (read or write) for addresses that fall within 16-byte boundaries.
- Memory must guarantee atomic access for addresses that fall within 16-byte boundaries.

The latter two capabilities — *indivisible* and *atomic* access — are required only when multiple processors or other external agents, such as DMA or graphics controllers, share a common memory.

|                    |  |
|--------------------|--|
| indivisible access | Guarantees that a processor, reading or writing a set of memory locations, completes the operation before another processor or external agent can read or write the same location. The processor requires indivisible access within an aligned 16-byte block of memory.  |
| atomic access      | A read-modify-write operation. Here the external memory system must guarantee that — once a processor begins a read-modify-write operation on an aligned, 16-byte block of memory — it is allowed to complete the operation before another processor or external agent is allowed access to the same location. An atomic memory system can be implemented by using the LOCK signal to qualify hold requests from external bus agents. LOCK is asserted for the duration of an atomic memory operation. |

The upper 16 Mbytes of the address space — addresses FF00 0000H through FFFF FFFFH — are reserved for implementation-specific functions. In general, programs can access this address space section unless an implementation specifically uses the memory or forbids access.

This address range is termed “reserved” so future i960 architecture implementations may use these addresses for special functions such as mapped registers or data structures. Therefore, to ensure complete object-level compatibility, portable code must not access or depend on values in this region. As shown in Figure 2-3, the initialization boot record is located in the i960 Cx processors’ reserved memory.

The i960 Cx processors require some special consideration when using the lower 1 Kbyte of address space (addresses 0000H-03FFH). Loads and stores directed to these addresses access internal memory; instruction fetches from these addresses are not allowed for the i960 Cx processors. See section 2.5.4, “Internal Data RAM” (pg. 2-12).



### 2.5.2 Data and Instruction Alignment in the Address Space

Instructions, program data and architecturally defined data structures can be placed anywhere in non-reserved address space while adhering to these alignment requirements:



- Align instructions on word boundaries.
- Align all architecturally defined data structures on the boundaries specified in Table 2-4.
- Align instruction operands for the atomic instructions (**atadd**, **atmod**) to word boundaries in memory.

The i960 Cx processors do not require that load and store data be aligned in memory. It can handle a non-aligned load or store request by either of two methods:

- It can automatically service a non-aligned memory access with microcode assistance as described in section 10.4, “DATA ALIGNMENT” (pg. 10-9).
- It can generate an operation unaligned fault when a non-aligned access is detected.

The method for handling non-aligned accesses is selected at initialization based on the value of the Fault Configuration Word in the Process Control Block. See section 14.2.6, “Process Control Block (PRCB)” (pg. 14-8).

**Table 2-4. Alignment of Data Structures in the Address Space**

| Data Structure             | Alignment           |
|----------------------------|---------------------|
| System Procedure Table     | 4 byte              |
| Interrupt Table            | 4 byte              |
| Fault Table                | 4 byte              |
| Control Table              | 16 byte             |
| User Stack                 | 16 byte             |
| Supervisor Stack           | 16 byte             |
| Interrupt Stack            | 16 byte             |
| Process Control Block      | 16 byte             |
| Initialization Boot Record | Fixed at FFFF FF00H |

### 2.5.3 Byte, Word and Bit Addressing

The processor provides instructions for moving data blocks of various lengths from memory to registers (**LOAD**) and from registers to memory (**STORE**). Allowable sizes for blocks are bytes, half-words (2 bytes), words (4 bytes), double words, triple words and quad words. For example, **stl** (store long) stores an 8 byte (double word) data block in memory.



The most efficient way to move data blocks longer than 16 bytes is to move them in quad-word increments, using quad-word instructions **ldq** and **stq**.

When a data block is stored in memory, normally the block's least significant byte is stored at a base memory address and the more significant bytes are stored at successively higher byte addresses. This method of ordering bytes in memory is referred to as "little endian" ordering.

The i960 Cx processors also provide the option for ordering bytes in an opposite manner in memory. The block's most significant byte is stored at the base address and the less significant bytes are stored at successively higher addresses. This byte ordering scheme — referred to as "big endian" — applies to data blocks which are short words or words. For more about byte ordering, see section 10.4, "DATA ALIGNMENT" (pg. 10-9).

When loading a byte, half word or word from memory to a register, the block's least significant bit is always loaded in register bit 0. When loading double words, triple words and quad words, the least significant word is stored in the base register. The more significant words are then stored at successively higher numbered registers. Bits can only be addressed in data that resides in a register; bit 0 in a register is the least significant bit, bit 31 is the most significant bit.

#### 2.5.4 Internal Data RAM

Internal data RAM is mapped to the lower 1 Kbyte (0000H to 03FFH) of the address space. Loads and stores, with target addresses in internal data RAM, operate directly on the internal data RAM; no external bus activity is generated. Data RAM allows time-critical data storage and retrieval without dependence on external bus performance. The lower 1 Kbyte of memory is data memory only. Instructions cannot be fetched from the internal data RAM. Instruction fetches directed to the data RAM cause a type mismatch fault to occur.

Some internal data RAM locations are reserved for functions other than general data storage (Figure 2-4). When the DMA controller is active, 32 bytes of data RAM are reserved for each channel in use. Additionally, 64 bytes of data RAM may be used to cache specific interrupt vectors. The word at location 0000H is always reserved for the cached NMI vector. With the exception of the cached NMI vector, other reserved portions of the data RAM can be used for data storage when the alternate function is not used.

As described in section 14.2.6, "Process Control Block (PRCB)" (pg. 14-8), local register cache size is specified by the value of the Process Control Block's Register Cache Configuration Word. The first five local register sets are cached internally; if more than five sets are to be cached, the local register cache can be extended into the internal data RAM. Up to ten more sets — occupying up to 640 bytes of data RAM — can be used. When the local register cache is extended, each new register set consumes 16 words of internal data RAM beginning at the highest data RAM address. The user program is responsible for preventing corruption to the internal RAM areas set aside for the register cache. See CHAPTER 5, PROCEDURE CALLS.





Internal RAM's first 256 bytes (0000H to 00FFH) are user mode write protected. This data RAM can be read while executing in user or supervisor mode; however, RAM can only be modified in supervisor mode. Writes to these locations while in user mode cause a type mismatch fault to be generated. This feature provides supervisor protection for DMA and Interrupt functions which use internal RAM. See section 2.7, "USER SUPERVISOR PROTECTION MODEL" (pg. 2-20). User mode write protection is optionally selected for the rest of the data RAM (0100H to 03FFH) by setting the Bus Configuration Register (BCON) RAM protection bit.

### 2.5.5 Instruction Cache

The instruction cache enhances performance by reducing the number of instruction fetches from external memory. The cache provides fast execution of cached code and loops of code in the cache and also provides more bus bandwidth for data operations in external memory. The i960 Cx processors' instruction cache is a two-way set associative cache, organized in two sets of eight-word lines. Each line is composed of four two-word blocks which can be replaced independently.

- The i960 CA processor cache is 1 Kbyte, organized as two sets of 16 eight-word lines.
- The i960 CF processor cache is 4 Kbytes, organized as two sets of 64 eight-word lines.

To optimize cache updates when branches or interrupts execute, each word in the line has a separate valid bit. Cache misses cause the processor to issue either double- or quad-word fetches to update the cache. Refer to APPENDIX A, INSTRUCTION EXECUTION AND PERFORMANCE OPTIMIZATION for a thorough discussion of the instruction cache operation.

Bus snooping is not implemented with the i960 Cx processors' cache. The cache does not detect modification to program memory by loads, stores or actions of other bus masters. Several situations may require program memory modification, such as uploading code at initialization or uploading code from a backplane bus or a disk.

To achieve cache coherence, instruction cache contents can be invalidated after code modification is complete. The **sysctl** instruction is used to invalidate the instruction cache for the i960 Cx component. **sysctl** is issued with an invalidate-instruction-cache message type. See section 4.3, "SYSTEM CONTROL FUNCTIONS" (pg. 4-19).

The user program is responsible for synchronizing a program with code modification and cache invalidation. In general, a program must ensure that modified code space is not accessed until modification and cache-invalidate is completed.

Instruction cache can be turned off, causing all instruction fetches to be directed to external memory. Disabling the instruction cache is useful for debugging or monitoring a system at the instruction prefetch level. To disable the instruction cache, **sysctl** is executed with the configure-instruction-cache message.

When the cache is disabled, the processor depends on a 16-word instruction buffer to provide decoding instructions. The instruction buffer is organized as two sets of two-way set associative cache with a four word line size. When the main cache is disabled, small loops of code may still execute entirely within the instruction buffer.

The processor can be directed to load a block of instructions into the cache and then disable all normal updates to this load cache portion. This cache load-and-lock mechanism is provided to optimize interrupt latency and throughput. The first instructions of time-critical interrupt routines are loaded into the locked cache. The interrupt, when serviced, is directed to the locked cache portion. No external accesses are required for these instructions when the interrupt is serviced.

Only interrupts can be directed to fetch instructions from the instruction cache’s locked portion. Other causes of program redirection always fetch from the normal memory hierarchy, even if the target address of the redirection is represented in the locked cache. When bit 1 of an interrupt vector is set to 1, the interrupt is fetched from the instruction cache’s locked portion. Execution continues from the locked cache until a miss occurs, such as a branch, call or return to code outside of the locked space. If an interrupt directed to the locked cache results in a miss, the targeted instruction is fetched from the normal memory hierarchy.

Either the full cache or half the cache can be configured to load and lock. When only half of the cache is loaded and locked, the other half acts as a normal two-way set associative cache. Normally, an application locks only half the cache. Locking the full cache means that all instruction fetches — except interrupts directed to the locked cache — come from external memory. See section 12.3.14, “Caching Interrupt-Handling Procedures” (pg. 12-21) for more details on the cache load and lock feature.

**sysctl** is issued with a configure-instruction-cache message type to select the load and lock mechanism. When the lock option is selected, an address is specified which points to a memory block to be loaded into the locked cache.

**2.5.6 Data Cache (80960CF Only)**

The i960 CF processor has a 1 Kbyte direct-mapped data cache which enhances performance by reducing the number of load and store accesses to external memory. The data cache can return up to a quad word (128 bits) to the register file in a single clock cycle on a cache hit. section A.1.8, “Data Cache (80960CF Only)” (pg. A-8) fully describes the data cache.

**2.6 PROCESSOR-STATE REGISTERS**

The architecture defines four 32-bit registers that contain status and control information:

- Instruction Pointer (IP) register
- Arithmetic Controls (AC) register
- Process Controls (PC) register
- Trace Controls (TC) register



### 2.6.1 Instruction Pointer (IP) Register

The IP register contains the address of the instruction currently being executed. This address is 32 bits long; however, since instructions are required to be aligned on word boundaries in memory, the IP's two least-significant bits are always 0 (zero).

All i960 processor instructions are either one or two words long. The IP gives the address of the lowest-order byte of the first word of the instruction.

The IP register cannot be read directly. However, the IP-with-displacement addressing mode allows the IP to be used as an offset into the address space. This addressing mode can also be used with the **lda** (load address) instruction to read the current IP value.

When a break occurs in the instruction stream — due to an interrupt, procedure call or fault — the IP of the next instruction to be executed is stored in local register r2 which is usually referred to as the return IP or RIP register. Refer to CHAPTER 5, PROCEDURE CALLS for further discussion of this operation.

### 2.6.2 Arithmetic Controls (AC) Register

The AC register (Figure 2-4) contains condition code flags, integer overflow flag, mask bit and a bit that controls faulting on imprecise faults. Unused AC register bits are reserved.

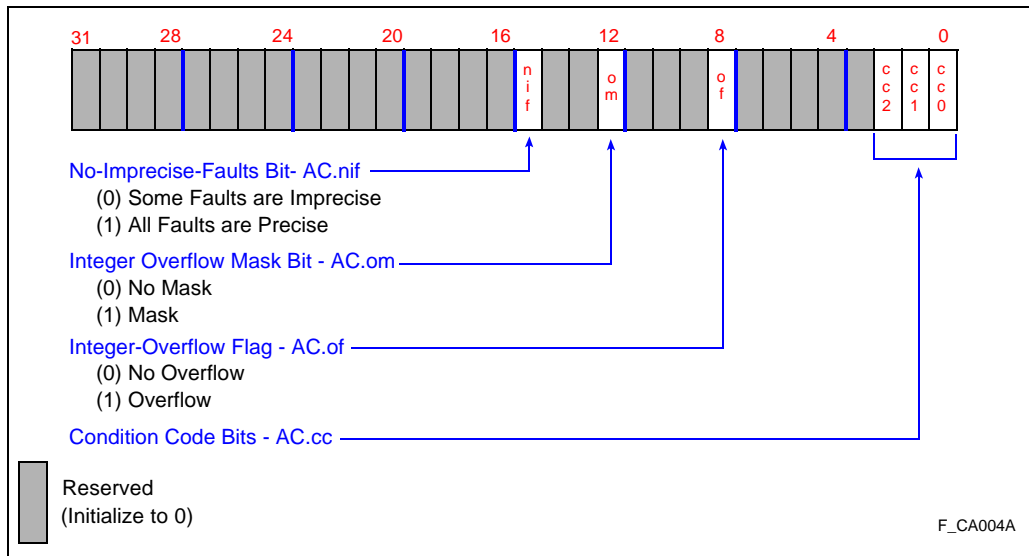


Figure 2-4. Arithmetic Controls (AC) Register

**2.6.2.1 Initializing and Modifying the AC Register**

At initialization, the AC register is loaded from the Initial AC image field in the Process Control Block. Reserved bits are set to 0 in the AC Register Initial Image. Refer to CHAPTER 14, INITIALIZATION AND SYSTEM REQUIREMENTS.

After initialization, software must not modify or depend on the AC register’s reserved location. The modify arithmetic controls (**modac**) instruction can be used to examine and/or modify any of the register bits. This instruction provides a mask operand that can be used to limit access to the register’s specific bits or groups of bits, such as the reserved bits.

The processor automatically saves and restores the AC register when it services an interrupt or handles a fault. The processor saves the current AC register state in an interrupt record or fault record, then restores the register upon returning from the interrupt or fault handler.

**2.6.2.2 Condition Code**

The processor sets the AC register’s *condition code flags* (bits 0-2) to indicate the results of certain instructions — usually compare instructions. Other instructions, such as conditional branch instructions, examine these flags and perform functions as dictated by the state of the condition code. Once the processor sets the condition code flags, the flags remain unchanged until another instruction executes that modifies the field.

Condition code flags show true/false conditions, inequalities (greater than, equal or less than conditions) or carry and overflow conditions for the extended arithmetic instructions. To show true or false conditions, the processor sets the flags as shown in Table 2-5. To show equality and inequalities, the processor sets the condition code flags as shown in Table 2-6.

**Table 2-5. Condition Codes for True or False Conditions**

| Condition Code   | Condition |
|------------------|-----------|
| 010 <sub>2</sub> | true      |
| 000 <sub>2</sub> | false     |

**Table 2-6. Condition Codes for Equality and Inequality Conditions**

| Condition Code   | Condition           |
|------------------|---------------------|
| 000 <sub>2</sub> | unordered (false)   |
| 001 <sub>2</sub> | greater than (true) |
| 010 <sub>2</sub> | equal               |
| 100 <sub>2</sub> | less than           |



Some i960 architecture implementations provide integrated floating point processing. The terms *ordered* and *unordered* are used when comparing floating point numbers. If, when comparing two floating point values, one of the values is a NaN (not a number), the relationship is said to be “unordered.” The i960 Cx processors do not implement on-chip floating point processing.

To show carry out and overflow, the processor sets the condition code flags as shown in Table 2-7.

**Table 2-7. Condition Codes for Carry Out and Overflow**

| Condition Code   | Condition |
|------------------|-----------|
| 01X <sub>2</sub> | carry out |
| 0X1 <sub>2</sub> | overflow  |

Certain instructions, such as the branch-if instructions, use a 3 bit mask to evaluate the condition code flags. For example, the branch-if-greater-or-equal instruction (**bge**) uses a mask of 011<sub>2</sub> to determine if the condition code is set to either greater-than or equal. These masks cover the additional conditions of greater-or-equal (011<sub>2</sub>), less-or-equal (110<sub>2</sub>) and not-equal (101<sub>2</sub>). The mask is part of the instruction opcode; the instruction performs a bitwise AND of the mask and condition code.

The AC register *integer overflow flag* (bit 8) and *integer overflow mask bit* (bit 12) are used in conjunction with the arithmetic-integer-overflow fault. The mask bit disables fault generation. When the fault is masked and integer overflow is encountered, the processor — instead of generating a fault — sets the integer overflow flag. If the fault is not masked, the fault is allowed to occur and the flag is not set.

Once the processor sets this flag, it never implicitly clears it; the flag remains set until the program clears it. Refer to the discussion of the arithmetic-integer-overflow fault in CHAPTER 7, FAULTS for more information about the integer overflow mask bit and flag.

The *no imprecise faults bit* (bit 15) determines whether or not faults are allowed to be imprecise. If set, all faults are required to be precise; if clear, certain faults can be imprecise. See section 7.9, “PRECISE AND IMPRECISE FAULTS” (pg. 7-17) for more information.

### 2.6.3 Process Controls (PC) Register

The PC register (Figure 2-5) is used to control processor activity and show the processor’s current state. PC register *execution mode flag* (bit 1) indicates that the processor is operating in either user mode (0) or supervisor mode (1). The processor automatically sets this flag on a system call when a switch from user mode to supervisor mode occurs and it clears the flag on a return from supervisor mode. (User and supervisor modes are described in section 2.7, “USER SUPERVISOR PROTECTION MODEL” (pg. 2-20)).

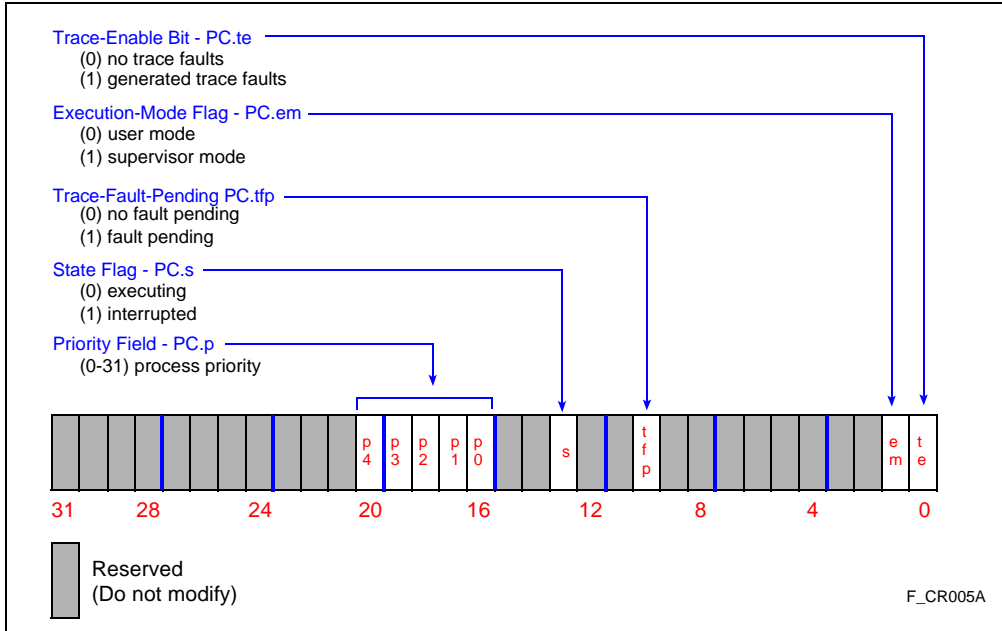


Figure 2-5. Process Controls (PC) Register

PC register *state flag* (bit 13) indicates processor state: executing (0) or interrupted (1). If the processor is servicing an interrupt, its state is interrupted. Otherwise, the processor’s state is executing.

While in the interrupted state, the processor can receive and handle additional interrupts. When nested interrupts occur, the processor remains in the interrupted state until all interrupts are handled, then switches back to executing state on the return from the initial interrupt procedure.

PC register *priority field* (bits 16 through 20) indicates the processor’s current executing or interrupted priority. The architecture defines a mechanism for prioritizing execution of code, servicing interrupts and servicing other implementation-dependent tasks or events. This mechanism defines 32 priority levels, ranging from 0 (the lowest priority level) to 31 (the highest). The priority field always reflects the current priority of the processor. Software can change this priority by use of the **modpc** instruction.

The processor uses the priority field to determine whether to service an interrupt immediately or to post the interrupt. The processor compares the priority of a requested interrupt with the current process priority. When the interrupt priority is greater than the current process priority or equal to 31, the interrupt is serviced; otherwise it is posted. When an interrupt is serviced, the process priority field is automatically changed to reflect interrupt priority. See CHAPTER 6, INTERRUPTS.



PC register *trace enable bit* (bit 0) and *trace fault pending flag* (bit 10) control the tracing function. The trace enable bit determines whether trace faults are to be generated (1) or not generated (0). The trace fault pending flag indicates that a trace event has been detected (1) or not detected (0).

### 2.6.3.1 Initializing and Modifying the PC Register

Any of the following three methods can be used to change bits in the PC register:

- Modify process controls instruction (**modpc**)
- Alter the saved process controls prior to a return from an interrupt handler
- Alter the saved process controls prior to a return from a fault handler

**modpc** directly reads and modifies the PC register. The processor must be in supervisor mode to execute this instruction; a type-mismatch fault is generated if **modpc** is executed in user mode. As with **modac**, **modpc** provides a mask operand that can be used to limit access to specific bits or groups of bits in the register.

In the latter two methods, the interrupt or fault handler changes process controls in the interrupt or fault record that is saved on the stack. Upon return from the interrupt or fault handler, the modified process controls are copied into the PC register. The processor must be in supervisor mode prior to return for modified process controls to be copied into the PC register.

When process controls are changed as described above, the processor recognizes the changes immediately except for one situation: if **modpc** is used to change the trace enable bit, the processor may not recognize the change before the next four instructions are executed.

After initialization (hardware reset), the process controls reflect the following conditions:

- priority = 31
- execution mode = supervisor
- trace enable = off
- state = interrupted

When the processor is reinitialized via the system control instruction and reinitialize message, the PC register reflects the same conditions, except that the processor retains the same priority as before reinitialization.

The reserved bits indicated in Figure 2-5 should never be set to zero; user software should not depend on the value of the reserved bits. Normally, **modpc** is not used to directly modify execution mode, trace fault pending and state flags except under special circumstances, such as in initialization code.

### 2.6.4 Trace Controls (TC) Register

The TC register, in conjunction with the PC register, controls processor tracing facilities. It contains trace mode enable bits and trace event flags which are used to enable specific tracing modes and record trace events, respectively. Trace controls are described in CHAPTER 8, TRACING AND DEBUGGING.

## 2.7 USER SUPERVISOR PROTECTION MODEL

The capability of a separate user and supervisor execution mode creates a code and data protection mechanism referred to as the user supervisor protection model. This mechanism allows code, data and stack for a kernel (or system executive) to reside in the same address space as code, data and stack for the application. The mechanism restricts access to all or parts of the kernel by the application code. This protection mechanism prevents application software from inadvertently altering the kernel.

### 2.7.1 Supervisor Mode Resources

The processor can be in either of two execution modes: user or supervisor. Supervisor mode is a privileged mode which provides several additional capabilities over user mode.

- When the processor switches to supervisor mode, it also switches to the supervisor stack. Switching to the supervisor stack helps maintain a kernel's integrity. For example, it allows system debugging software or a system monitor to be accessed, even if an application's program destroys its own stack.
- When an instruction executed in supervisor mode causes a bus access to occur, an external supervisor pin  $\overline{\text{SUP}}$  is asserted for loads, stores and instruction fetches. Hardware protection of system code or data can be implemented by using the supervisor pin to qualify write accesses to the protected memory.
- In supervisor mode, the processor is allowed access to a set of supervisor-only functions and instructions. For example, the processor uses supervisor mode to handle interrupts and trace faults. Operations which can modify DMA or interrupt controller behavior or reconfigure bus controller characteristics can only be performed in supervisor mode. These functions include modification of SFRs, control registers or internal data RAM which is dedicated to the DMA and interrupt controllers. A fault is generated if supervisor-only operations are attempted while the processor is in user mode. Table 2-8 lists supervisor-only operations and the fault which is generated if the operation is attempted in user mode.

The PC register execution mode flag specifies processor execution mode. The processor automatically sets and clears this flag when it switches between the two execution modes.





Table 2-8. Supervisor-Only Operations and Faults Generated in User Mode

| Supervisor-Only Operation              | User-Mode Fault       |
|--|-----------------------|
| <b>modpc</b> (modify process controls) | type-mismatch         |
| <b>sysctl</b> (system control)         | constraint-privileged |
| <b>sdma</b> (setup DMA)                | constraint-privileged |
| SFR as instruction operand             | type-mismatch         |
| Protected internal data RAM write      | type-mismatch         |

### 2.7.2 Using the User-Supervisor Protection Model

A program switches from user mode to supervisor mode by making a system-supervisor call (also referred to as a supervisor call). A system-supervisor call is a call executed with the call-system instruction (**calls**). With the **calls** instruction, the IP for the called procedure comes from the system procedure table. An entry in the system procedure table can specify an execution mode switch to supervisor mode when the called procedure is executed. The **calls** instruction and the system procedure table thus provide a tightly controlled interface to procedures which can execute in supervisor mode. Once the processor switches to supervisor mode, it remains in that mode until a return is performed to the procedure that caused the original mode switch.

Interrupts and some faults also cause the processor to switch from user to supervisor mode. When the processor handles an interrupt, it automatically switches to supervisor mode. However, it does not switch to the supervisor stack. Instead, it switches to the interrupt stack.

Figure 2-6 shows a system which implements the user-supervisor protection model to protect kernel code and data. The code and data structures in the shaded areas can only be accessed in supervisor mode.

In this example, kernel procedures are accessed through the system procedure table with system-supervisor calls. These procedures execute in supervisor mode. Some application procedures are also called through the system procedure table using a system-local call. Fault procedures are executed in supervisor mode by directing the faults through the system procedure table. Interrupt procedures, which are likely to modify SFRs, process controls or use other supervisor operations, are executed in supervisor mode. The interrupt stack and supervisor stack are insulated from the user stack in this system.

If an application does not require a user-supervisor protection mechanism, the processor can always execute in supervisor mode. At initialization, the processor is placed in supervisor mode prior to executing the first instruction of the application code. The processor then remains in supervisor mode indefinitely, as long as no action is taken to change execution mode to user mode. The processor does not need a user stack in this case.

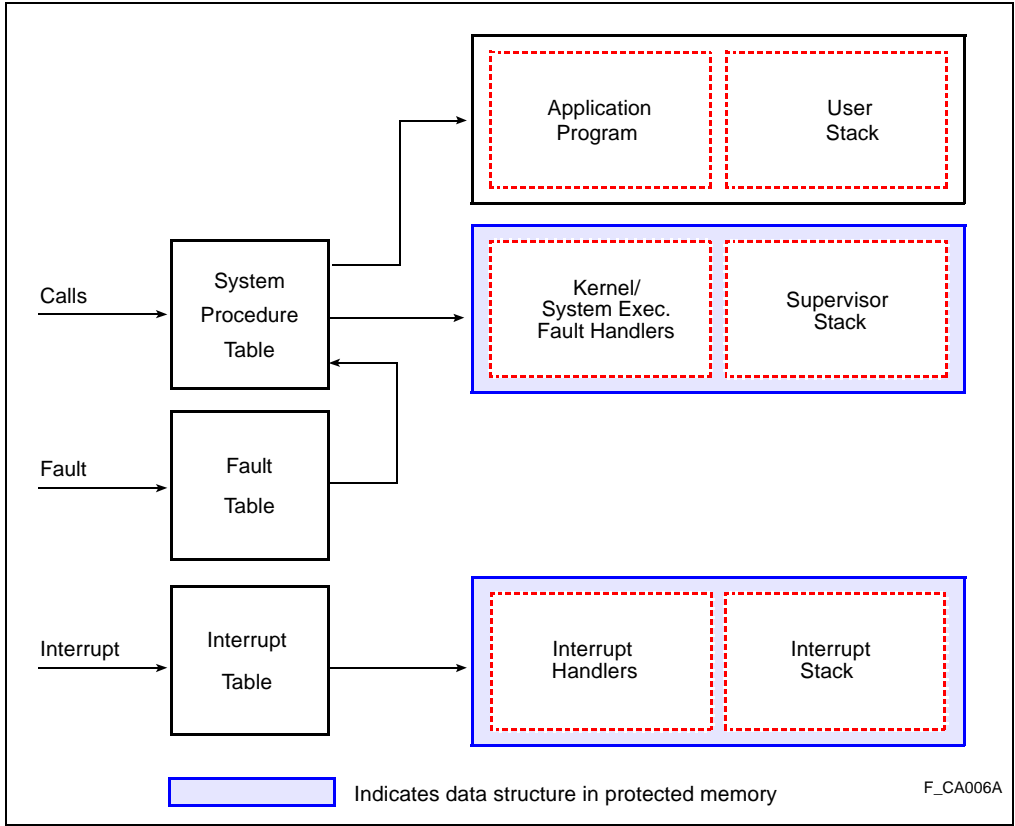


Figure 2-6. Example Application of the User-Supervisor Protection Model



DATA TYPES AND MEMORY  
ADDRESSING MODES





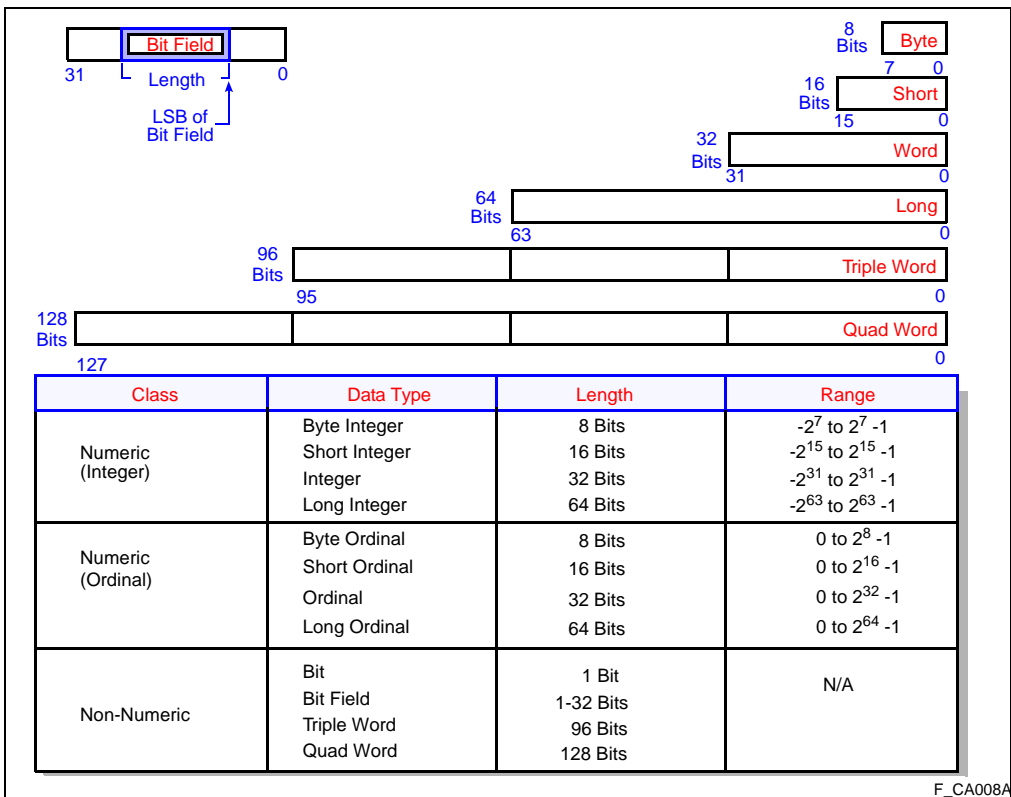
# CHAPTER 3 DATA TYPES AND MEMORY ADDRESSING MODES

## 3.1 DATA TYPES

The instruction set references or produces several data lengths and formats. The i960® architecture defines the following data types:

- Integer (8, 16, 32 and 64 bits)
- Triple Word (96 bits)
- Bit
- Ordinal (unsigned integer 8, 16, 32 and 64 bits)
- Quad Word (128 bits)
- Bit Field

Figure 3-1 shows i960 architecture data types and the length and numeric range of each.



**Figure 3-1. Data Types and Ranges**

**3.1.1 Integers**

Integers are signed whole numbers which are stored and operated on in two’s complement format by the integer instructions. Most integer instructions operate on 32-bit integers. Byte and short integers are only referenced by the byte and short classes of the load and store instructions. None of the i960 Cx processor instructions reference or produce the long-integer data type. Table 3-1 shows the supported integer sizes.

**Table 3-1. Supported Integer Sizes**

| Integer size | Descriptive name |
|--------------|------------------|
| 8 bit        | byte integers    |
| 16 bit       | short integer    |
| 32 bit       | integers         |
| 64 bit       | long integers    |

**NOTE:**

HLL compilers may define long integer types differently than the i960 architecture.

Integer load or store size (byte, short or word) determines how sign extension or data truncation is performed when data is moved between registers and memory.

For instructions **ldib** (load integer byte) and **ldis** (load integer short), a byte or short word in memory is considered a two’s complement value. The value is sign-extended and placed in the 32-bit register which is the destination for the load.

For instructions **stib** (store integer byte) and **stis** (store integer short), a 32-bit two’s complement number in a register is stored to memory as a byte or short-word. If register data is too large to be stored as a byte or short word, the value is truncated and the integer overflow condition is signalled. When an overflow occurs, either an AC register flag is set or the integer overflow fault is generated. CHAPTER 7, FAULTS describes the integer overflow fault.

For instructions **ld** (load word) and **st** (store word), data is moved directly between memory and a register with no sign extension or data truncation.



### 3.1.2 Ordinals

Ordinals — unsigned integer data types — are stored and operated on as positive binary values. Table 3-2 shows the supported ordinal sizes.

**Table 3-2. Supported Ordinal Sizes**

| Ordinal size | Descriptive name |
|--------------|------------------|
| 8 bit        | byte ordinals    |
| 16 bit       | short ordinals   |
| 32 bit       | ordinals         |
| 64 bit       | long ordinals    |

3

The large number of instructions that perform logical, bit manipulation and unsigned arithmetic operations reference 32-bit ordinal operands. When ordinals are used to represent Boolean values, 1 = TRUE and 0 = FALSE. Several extended arithmetic instructions reference the long ordinal data type. Only load and store instructions reference the byte and short ordinal data types.

Sign and sign extension is not a consideration when ordinal loads and stores are performed; the values may, however, be zero extended or truncated. A short word or byte load to a register causes the value loaded to be zero extended to 32 bits. A short word or byte store to memory may cause an ordinal value in a register to be truncated to fit its destination in memory. No overflow condition is signalled in this case.

### 3.1.3 Bits and Bit Fields

The processor provides several instructions that perform operations on individual bits or bit fields within register operands. An individual bit is specified for a bit operation by giving its bit number and register. The least significant bit of a 32-bit register is bit 0; the most significant bit is bit 31.

A bit field is a contiguous sequence of bits within a register operand. Bit fields do not span register boundaries. A bit field is defined by giving its length in bits (0-31) and the bit number of its lowest numbered bit (0-31). In other words, the bit field is any contiguous group of bits (up to 31 bits long) in a 32-bit register.

Loading and storing of bit and bit field data is normally performed using the ordinal load and store instructions. Integer load and store instructions operate on two's complement numbers. Depending on the value, a byte or short integer load can result in sign extension of data in a register. A byte or short store can signal an integer overflow condition.

## DATA TYPES AND MEMORY ADDRESSING MODES

### 3.1.4 Triple and Quad Words

Triple- and quad-words refer to consecutive words in memory or in registers. Triple- and quad-word loads, stores and move instructions use these data types. These instructions facilitate data block movement. No data manipulation (sign extension, zero extension or truncation) is performed in these instructions.

Triple- and quad-word data types can be considered a superset of — or as encompassing — the other data types described. The data in each word subset of a quad word is likely to be the operand or result of an ordinal, integer, bit or bit field instruction.

### 3.1.5 Data Alignment

Data in registers and memory must adhere to specific alignment requirements:

- Align long-word operands in registers to double-register boundaries.
- Align triple- and quad-word operands in registers to quad-register boundaries.

For the i960 Cx processors, data alignment in memory is not required. Unaligned memory accesses — by programmable option — can either cause a fault or be handled automatically. Refer to section 2.5.2, “Data and Instruction Alignment in the Address Space” (pg. 2-11) for a complete description of alignment requirements for data and instructions.

## 3.2 BYTE ORDERING

The i960 Cx processors can be programmed to use little- or big endian-byte ordering for memory accesses. Byte ordering refers to how data items larger than one byte are assembled:

- For little-endian byte order, the byte with the lowest address in a multi-byte data item has the *least* significance.
- For big-endian byte order, the byte with the lowest address in a multi-byte data item has the *most* significance.

For example, Table 3-3 shows 4 bytes of data in memory. Table 3-4 shows the differences between little- and big-endian accesses for byte, short and word data. Figure 3-2 shows the resultant data placement in registers.

Once data is read into registers, byte order is no longer relevant. The lowest significant bit is always bit 0. The most significant bit is always bit 31 for words, bit 5 for short words, and bit 7 for bytes.





Table 3-3. Memory Contents For Little and Big Endian Example

| ADDRESS | DATA |
|---------|------|
| 100H    | 12H  |
| 101H    | 34H  |
| 102H    | 56H  |
| 103H    | 78H  |

3

Table 3-4. Byte Ordering for Little and Big Endian Accesses

| Access        | Example        | Little Endian | Big Endian |
|---------------|----------------|---------------|------------|
| Byte at 100H  | ldob 0x100, r3 | 12H           | 12H        |
| Short at 102H | ldos 0x102, r3 | 7856H         | 5678H      |
| Word at 100H  | ld 0x100, r3   | 78563412H     | 12345678H  |

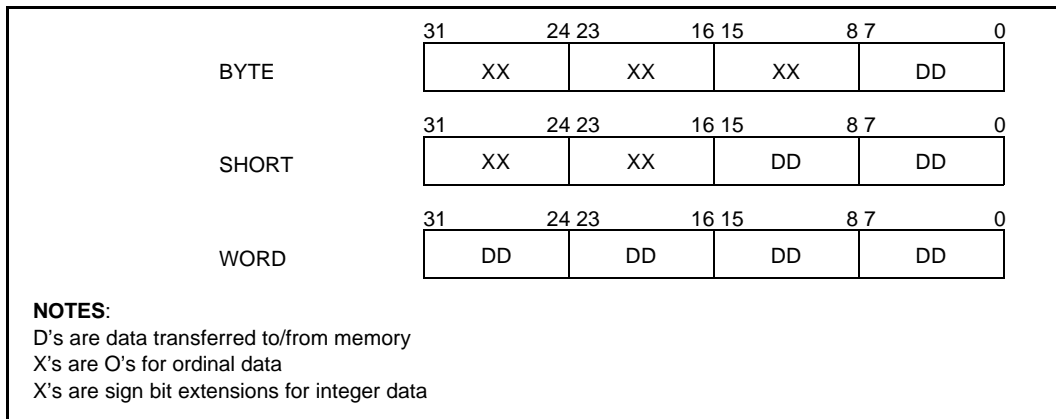


Figure 3-2. Data Placement in Registers

### 3.3 MEMORY ADDRESSING MODES

The processor provides nine modes for addressing operands in memory. Each addressing mode is used to reference a byte in the processor's address space. Table 3-5 shows the memory addressing modes, a brief description of each mode's address elements and assembly code syntax.



Table 3-5. Memory Addressing Modes

| Mode                               | Description                          | Assembler Syntax      |
|------------------------------------|--------------------------------------|-----------------------|
| Absolute <i>offset</i>             | offset                               | exp                   |
| <i>displacement</i>                | displacement                         | exp                   |
| Register Indirect                  | abase                                | (reg)                 |
| <i>with offset</i>                 | abase + offset                       | exp (reg)             |
| <i>with displacement</i>           | abase + displacement                 | exp (reg)             |
| <i>with index</i>                  | abase + (index*scale)                | (reg) [reg*scale]     |
| <i>with index and displacement</i> | abase + (index*scale) + displacement | exp (reg) [reg*scale] |
| Index with displacement            | (index*scale) + displacement         | exp [reg*scale]       |
| IP with displacement               | IP + displacement + 8                | exp (IP)              |

**NOTE:** *reg* is register and *exp* is an expression or symbolic label.

### 3.3.1 Absolute

Absolute addressing modes allow a memory location to be referenced directly as an offset from address 0H. At the instruction encoding level, two absolute addressing modes are provided: absolute offset and absolute displacement, depending on offset size.

- For the absolute offset addressing mode, the offset is an ordinal number ranging from 0 to 4095. The absolute offset addressing mode is encoded in the MEMA machine instruction format.
- For the absolute displacement addressing mode the offset is an integer (a displacement) ranging from  $-2^{31}$  to  $2^{31}-1$ . The absolute displacement addressing mode is encoded in the MEMB format.

Encoding level addressing modes and instruction formats are described in CHAPTER 9, INSTRUCTION SET REFERENCE.

At the assembly language level, the two absolute addressing modes are combined into one. Both modes use the same syntax. Typically, development tools allow absolute addresses to be specified through arithmetic expressions (e.g.,  $x + 44$ ) or symbolic labels. After evaluating an address specified with the absolute addressing mode, the assembler converts the address into an offset or displacement and selects the appropriate instruction encoding format and addressing mode.

### 3.3.2 Register Indirect

Register indirect addressing modes use a register’s 32-bit value as a base for address calculation. The register value is referred to as the address base (designated *abase* in Table 3-5). Depending on the addressing mode, an optional scaled-index and offset can be added to this address base.



Register indirect addressing modes are useful for addressing elements of an array or record structure. When addressing array elements, the abase value provides the address of the first array element; an offset (or displacement) selects a particular array element.

In register-indirect-with-index addressing mode, the index is specified using a value contained in a register. This index value is multiplied by a scale factor; allowable factors are 1, 2, 4, 8 and 16.

The two versions of register-indirect-with-offset addressing mode at the instruction encoding level are register-indirect-with-offset and register-indirect-with-displacement. As with absolute addressing modes, the mode selected depends on the size of the offset from the base address.

At the assembly language level, the assembler allows the offset to be specified with an expression or symbolic label, then evaluates the address to determine whether to use register-indirect-with-offset (MEMA format) or register-indirect-with-displacement (MEMB format) addressing mode.

Register-indirect-with-index-and-displacement addressing mode adds both a scaled index and a displacement to the address base. There is only one version of this addressing mode at the instruction encoding level; it is encoded in the MEMB instruction format.

### 3.3.3 Index with Displacement

A scaled index can also be used with a displacement alone. Again, the index is contained in a register and multiplied by a scaling constant before displacement is added.

### 3.3.4 IP with Displacement

This addressing mode is used with load and store instructions to make them IP relative. IP-with-displacement addressing mode references the next instruction's address plus the displacement plus a constant of 8. The constant is added because — in a typical processor implementation — the address has incremented beyond the next instruction address at the time of address calculation. The constant simplifies IP-with-displacement addressing mode implementation.

### 3.3.5 Addressing Mode Examples

The following examples show how i960 addressing modes are encoded in assembly language. Example 3-1 shows addressing mode mnemonics. Example 3-2 illustrates the usefulness of scaled index and scaled index plus displacement addressing modes. In this example, a procedure named `array_op` uses these addressing modes to fill two contiguous memory blocks separated by a constant offset. A pointer to the top of the block is passed to the procedure in `g0`, the block size is passed in `g1` and the fill data in `g2`.

**Example 3-1. Addressing Mode Mnemonics**

|      |                  |   |
|------|------------------|---|
| st   | g4,xyz           | # absolute; word from g4 stored at memory<br># location designated with label xyz.  |
| ldob | (r3),r4          | # register indirect; ordinal byte from<br># memory location given in r3 loaded<br># into register r4 and zero extended.           |
| stl  | g6,xyz(g5)       | # register indirect with displacement;<br># double word from g6,g7 stored at memory<br># location xyz + g5.                       |
| ldq  | (r8)[r9*4],r4    | # register indirect with index; quad-word<br># beginning at memory location r8 + (r9<br># scaled by 4) loaded into r4 through r7. |
| st   | g3,xyz(g4)[g5*2] | # register indirect with index and<br># displacement; word in g3 loaded to mem<br># location g4 + xyz + (g5 scaled by 2).         |
| ldis | xyz[r12*1],r13   | # index with displacement; load short<br># integer at memory location xyz + r12<br># into r13 and sign extended.                  |
| st   | r4,xyz(IP)       | # IP with displacement; store word in r4<br># at memory location IP + xyz + 8.  |

**Example 3-2. Use of Index Plus Scaled Index Mode**

```

array_op:
    mov     g0,r4           # pointer to array is moved to r4
    subi   1,g1,r3         # calculate index for the last array
    b      .I33            # element to be filled.
.I34:
    st     g2,(r4)[r3*4]   # fill array at index
    st     g2,0x30(r4)[r3*4] #fill array at index+constant offset
    subi   1,r3,r3         # decrement index
.I33:
    cmpibl 0,r3,.I34      # store next array elements if
    ret                                # index is not 0
    
```





4

# INSTRUCTION SET SUMMARY

|



## CHAPTER 4

# INSTRUCTION SET SUMMARY

This chapter overviews the i960® microprocessor family's instruction set and i960 Cx processor-specific instruction set extensions. Also discussed are the assembly-language and instruction-encoding formats, various instruction groups and each group's instructions.

4

CHAPTER 9, INSTRUCTION SET REFERENCE describes each instruction — including assembly language syntax — and the action taken when the instruction executes and examples of how to use the instruction.

### 4.1 INSTRUCTION FORMATS

Instructions described in this manual are in two formats: assembly language and instruction encoding. The following subsections briefly describe these formats.

#### 4.1.1 Assembly Language Format

Throughout this manual, instructions are referred to by their assembly language mnemonics. For example, the add ordinal instruction is referred to as **addo**. Examples use Intel 80960 assembler assembly language syntax which consists of the instruction mnemonic followed by zero to three operands, separated by commas. In the following assembly language statement example for **addo**, ordinal operands in global registers g5 and g9 are added together; the result is stored in g7:

```
addo g5, g9, g7    # g7 ← g9 + g5
```

In the assembly language listings in this chapter, registers are denoted as:

|    |                           |   |                               |
|----|---------------------------|---|-------------------------------|
| g  | global register           | r | local register                |
| sf | special function register | # | pound sign precedes a comment |

All numbers used as literals or in address expressions are assumed to be decimal. Hexadecimal numbers are denoted with a “0x” prefix (e.g., 0xffff0012). Several assembly language instruction statement examples follow. Additional assembly language examples are given in section 3.3.5, “Addressing Mode Examples” (pg. 3-7). Further information about assembly language syntax can be found in Intel's *i960® Processor Assembler User's Guide* (order #485276).

```
subi r3, r5, r6    #r6 ← r5 - 3
setbit 13, g4, g5  #g5 ← g4 with bit 13 set
lda 0xfab3, r12   #r12← 0xfab3
ld (r4), g3      #g3 ← memory location that g4 points to
st g10, (r6)[r7*2] #g10← memory location that r6+2*r7 points to
```

### 4.1.2 Branch Prediction

Branch prediction is an implementation-specific feature of the i960 Cx processors. Not every implementation of the i960 architecture uses the branch prediction bit.

Since branch instruction actions depend on the result of a previous comparison, the architecture allows a programmer to predict the likely result of the branch operation for increased performance. The programmer's prediction is encoded in one bit of the machine language instruction. 80960 assemblers encode the prediction with a mnemonic suffix: `.t` = true, `.f` = false. Use the `.t` suffix to speed up execution when an instruction usually takes a branch; use the `.f` suffix when an instruction usually does not take a branch.

Because test and conditional-fault instructions also use condition codes, prediction suffixes are also implemented on these instructions. Refer to section A.2.7.7, "Branch Prediction" (pg. A-53).

### 4.1.3 Instruction Encoding Formats

All instructions are encoded in one 32-bit machine language instruction — also known as an opword — which must be word aligned in memory. An opword's most significant eight bits contain the opcode field. The opcode field determines the instruction to be performed and how the remainder of the machine language instruction is interpreted. Instructions are encoded in opwords in one of four formats (see Figure 4-1).

| Instruction Type   | Format | Description  |
|--------------------|--------|--|
| register           | REG    | Most instructions are encoded in this format. Used primarily for instructions which perform register-to-register operations.   |
| compare and branch | COBR   | An encoding optimization which combines compare and branch operations into one opword. Other compare and branch operations are also provided as REG and CTRL format instructions.  |
| control            | CTRL   | Used for branches and calls that do not depend on registers for address calculation.   |
| memory             | MEM    | Used for referencing an operand which is a memory address. Load and store instructions — and some branch and call instructions — use this format. MEM format has two encodings: MEMA or MEMB. Usage depends upon the addressing mode selected. MEMB-formatted addressing modes use the word in memory immediately following the instruction opword as a 32-bit constant. |





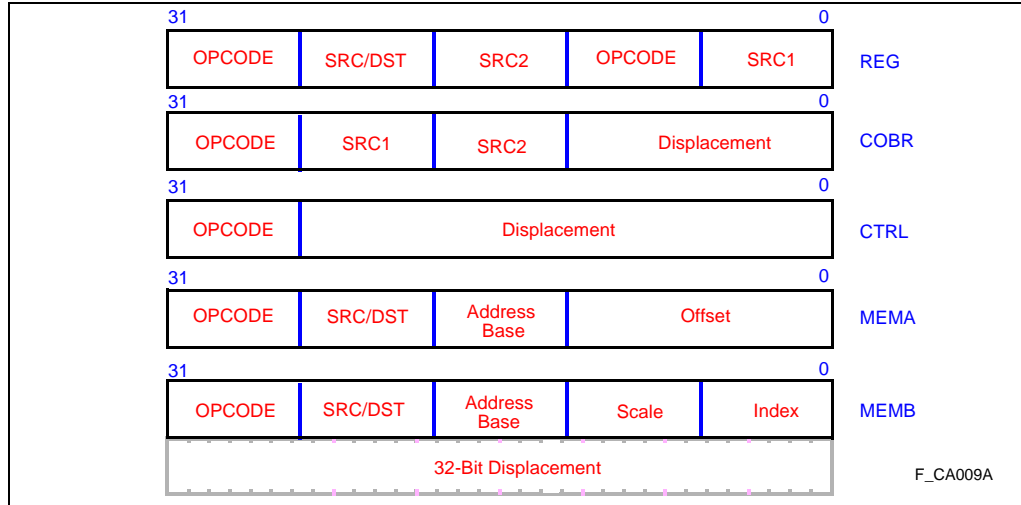


Figure 4-1. Machine-Level Instruction Formats

#### 4.1.4 Instruction Operands

This section identifies and describes operands that can be used with the instruction formats.

| Format | Operand(s)                      | Description   |
|--------|---------------------------------|---|
| REG    | <i>src1, src2, src/dst</i>      | <i>src1</i> and <i>src2</i> can be global registers, local registers, special function registers or literals. <i>src/dst</i> is either a global, local or special function register.  |
| CTRL   | <i>displacement</i>             | CTRL format is used for branch and call instructions. <i>displacement</i> value indicates the target instruction of the branch or call.   |
| COBR   | <i>src1, src2, displacement</i> | <i>src1, src2</i> indicate values to be compared; displacement indicates branch target. <i>src1</i> can specify a global register, local register or a literal. <i>src2</i> can specify a global, local or special function register. See section 2.2.3, “Special Function Registers (SFRs)” (pg. 2-4). |
| MEM    | <i>src/dst, efa</i>             | Specifies source or destination register and an effective address ( <i>efa</i> ) formed by using the processor’s addressing modes as described in section 3.3, “MEMORY ADDRESSING MODES” (pg. 3-5). Registers specified in a MEM format instruction must be either a global or local register.          |



# INSTRUCTION SET SUMMARY

## 4.2 INSTRUCTION GROUPS

The i960 processor instruction set can be categorized into the following functional groups:

- Data Movement
- Bit, Bit Field and Byte
- Call/Return
- Atomic
- Arithmetic (Ordinal and Integer)
- Comparison
- Fault
- Processor Management
- Logical
- Branch
- Debug

Table 4-1 shows the instructions in these groups. The actual number of instructions is greater than those shown in this list because — for some operations — several unique instructions are provided to handle various operand sizes, data types or branch conditions. The following sections briefly overview the instructions in each group.

**Table 4-1. i960<sup>®</sup> Cx Microprocessor Instruction Set Summary**

| Data Movement  | Arithmetic  | Logical   | Bit, Bit Field, Byte  |
|--|---|---|---|
| Load<br>Store<br>Move<br>Load Address  | Add<br>Subtract<br>Multiply<br>Divide<br>Add with carry<br>Subtract with carry<br>Extended Multiply<br>Extended Divide<br>Remainder<br>Modulo<br>Shift<br>*Extended Shift<br>Rotate | AND<br>NOT AND<br>AND NOT<br>OR<br>Exclusive OR<br>NOT OR<br>OR NOT<br>NOT<br>Exclusive NOR<br>NOR<br>NAND        | Set Bit<br>Clear Bit<br>Not Bit<br>Alter Bit<br>Scan For Bit<br>Span Over Bit<br>Extract<br>Modify<br>Scan Byte For Equal |
| Comparison   | Branch  | Call/Return   | Fault   |
| Compare<br>Conditional Compare<br>Check Bit<br>Compare and Increment<br>Compare and Decrement<br>Test Condition Code | Unconditional Branch<br>Conditional Branch<br>Compare and Branch  | Call<br>Call Extended<br>Call System<br>Return<br>Branch and Link   | Conditional Fault<br>Synchronize Faults   |
| Debug  | Atomic  | Processor   |   |
| Modify Trace Controls<br>Mark<br>Force Mark  | Atomic Add<br>Atomic Modify   | Flush Local Registers<br>Modify Arithmetic Controls<br>Modify Process Controls<br>*System Control<br>*DMA Control |   |

**NOTE:** Asterisk (\*) denotes instructions that are i960 Cx processor-specific extensions to the i960 processor family's instruction set.



## 4.2.1 Data Movement

These instructions are used to move data from memory to global and local registers; from global and local registers to memory; and data among local, global and special function registers.

Rules for register alignment must be followed when using load, store and move instructions that move 8, 12 or 16 bytes at a time. See section 2.5, “MEMORY ADDRESS SPACE” (pg. 2-9) for alignment requirements for code portability across implementations.

4

### 4.2.1.1 Load and Store Instructions

Load instructions listed below copy bytes or words from memory to local or global registers or to a group of registers. Each load instruction requires a corresponding store instruction to copy to memory bytes or words from a selected local or global register or group of registers. All load and store instructions use the MEM format.

|             |                    |             |                     |
|-------------|--------------------|-------------|---------------------|
| <b>ld</b>   | load word          | <b>st</b>   | store word          |
| <b>ldob</b> | load ordinal byte  | <b>stob</b> | store ordinal byte  |
| <b>ldos</b> | load ordinal short | <b>stos</b> | store ordinal short |
| <b>ldib</b> | load integer byte  | <b>stib</b> | store integer byte  |
| <b>ldis</b> | load integer short | <b>stis</b> | store integer short |
| <b>ldl</b>  | load long          | <b>stl</b>  | store long          |
| <b>ldt</b>  | load triple        | <b>stt</b>  | store triple        |
| <b>ldq</b>  | load quad          | <b>stq</b>  | store quad          |

**ld** copies 4 bytes from memory into successive registers; **ldl** copies 8 bytes; **ldt** copies 12 bytes; **ldq** copies 16 bytes.

**st** copies 4 bytes from successive registers into memory; **stl** copies 8 bytes; **stt** copies 12 bytes; **stq** copies 16 bytes.

For **ld**, **ldob**, **ldos**, **ldib** and **ldis**, the instruction specifies a memory address and register; the memory address value is copied into the register. The processor automatically extends byte and short (half-word) operands to 32 bits according to data type. Ordinals are zero-extended; integers are sign-extended.

For **st**, **stob**, **stos**, **stib** and **stis**, the instruction specifies a memory address and register; the register value is copied into memory. For byte and short instructions, the processor automatically reformats the source register’s 32-bit value for the shorter memory location. For **stib** and **stis**, this reformatting can cause integer overflow if the register value is too large for the shorter memory location. When integer overflow occurs, either an integer-overflow fault is generated or the integer-overflow flag in the AC register is set, depending on the integer-overflow mask bit setting in the AC register.

## INSTRUCTION SET SUMMARY

For **stob** and **stos**, the processor truncates the operand and does not create a fault if truncation resulted in the loss of significant bits.

### 4.2.1.2 Move

Move instructions copy data from a local, global, special function register or group of registers to another register or group of registers. These instructions use the REG format.

|             |                  |
|-------------|------------------|
| <b>mov</b>  | move word        |
| <b>movl</b> | move long word   |
| <b>movt</b> | move triple word |
| <b>movq</b> | move quad word   |

### 4.2.1.3 Load Address

The Load Address instruction (**lda**) computes an effective address in the address space from an operand presented in one of the addressing modes. **lda** is commonly used to load a constant into a register. This instruction uses the MEM format and can operate upon local or global registers.

On the i960 Cx processors, **lda** is useful for performing simple arithmetic operations. The processor's parallelism allows **lda** to execute in the same clock as another arithmetic or logical operation.

## 4.2.2 Arithmetic

Table 4-2 lists arithmetic operations and data types for which the i960 Cx processors provide instructions. "X" in this table indicates that the microprocessor provides an instruction for the specified operation and data type. Extended shift right operation is an i960 Cx processor-specific extension to the i960 processor family's instruction set. All arithmetic operations are carried out on operands in registers. Refer to section 4.2.11, "Atomic Instructions" (pg. 4-18) for instructions which handle specific requirements for in-place memory operations.

All arithmetic instructions use the REG format and can operate on local, global or special function registers. The following subsections describe arithmetic instructions for ordinal and integer data types.



Table 4-2. Arithmetic Operations

| Arithmetic Operations        | Data Types |         |
|------------------------------|------------|---------|
|                              | Integer    | Ordinal |
| Add                          | X          | X       |
| Add with Carry               | X          | X       |
| Subtract                     | X          | X       |
| Subtract with Carry          | X          | X       |
| Multiply                     | X          | X       |
| Extended Multiply            |            | X       |
| Divide                       | X          | X       |
| Extended Divide              |            | X       |
| Remainder                    | X          | X       |
| Modulo                       | X          |         |
| Shift Left                   | X          | X       |
| Shift Right                  | X          | X       |
| *Extended Shift Right        |            | X       |
| Shift Right Dividing Integer | X          |         |

**NOTE:** \*i960 Cx processor-specific extension to the 80960 instruction set.

4

**4.2.2.1 Add, Subtract, Multiply and Divide**

These instructions perform add, subtract, multiply or divide operations on integers and ordinals:

- addi**      add integer
- addo**      add ordinal
- subi**      subtract integer
- subo**      subtract ordinal
- muli**      multiply integer
- mulo**      multiply ordinal
- divi**      divide integer
- divo**      divide ordinal

**addi**, **subi**, **muli** and **divi** generate an integer-overflow fault if the result is too large to fit in the 32-bit destination. **divi** and **divo** generate a zero-divide fault if the divisor is zero.



## INSTRUCTION SET SUMMARY

**4.2.2.2 Extended Arithmetic**

These instructions support extended-precision arithmetic; i.e., arithmetic operations on operands greater than one word in length:

|             |                             |
|-------------|-----------------------------|
| <b>addc</b> | add ordinal with carry      |
| <b>subc</b> | subtract ordinal with carry |
| <b>emul</b> | extended multiply           |
| <b>ediv</b> | extended divide             |

**addc** adds two word operands (literals or contained in registers) plus the AC Register condition code bit 1 (used here as a carry bit). If the result has a carry, bit 1 of the condition code is set; otherwise, it is cleared. This instruction's description in CHAPTER 9, INSTRUCTION SET REFERENCE gives an example of how this instruction can be used to add two long-word (64-bit) operands together.

**subc** is similar to **addc**, except it is used to subtract extended-precision values. Although **addc** and **subc** treat their operands as ordinals, the instructions also set bit 0 of the condition codes if the operation would have resulted in an integer overflow condition. This facilitates a software implementation of extended integer arithmetic.

**emul** multiplies two ordinals (each contained in a register), producing a long ordinal result (stored in two registers). **ediv** divides a long ordinal by an ordinal, producing an ordinal quotient and an ordinal remainder (stored in two adjacent registers).

**4.2.2.3 Remainder and Modulo**

These instructions divide one operand by another and retain the remainder of the operation:

|             |                   |
|-------------|-------------------|
| <b>remi</b> | remainder integer |
| <b>remo</b> | remainder ordinal |
| <b>modi</b> | modulo integer    |

The difference between the remainder and modulo instructions lies in the sign of the result. For **remi** and **remo**, the result has the same sign as the dividend; for **modi**, the result has the same sign as the divisor.



#### 4.2.2.4 Shift and Rotate

These shift instructions shift an operand a specified number of bits left or right:

|               |                              |
|---------------|------------------------------|
| <b>shlo</b>   | shift left ordinal           |
| <b>shro</b>   | shift right ordinal          |
| <b>shli</b>   | shift left integer           |
| <b>shri</b>   | shift right integer          |
| <b>shrdi</b>  | shift right dividing integer |
| <b>rotate</b> | rotate left                  |
| <b>eshro</b>  | extended shift right ordinal |

**4**

Except for **rotate**, these instructions discard bits shifted beyond the register boundary.

**shlo** shifts zeros in from the least significant bit; **shro** shifts zeros in from the most significant bit. These instructions are equivalent to **mulo** and **divo** by the power of 2, respectively.

**shli** shifts zeros in from the least significant bit. If a shift of the specified places would result in an overflow, an integer-overflow fault is generated (if enabled). The destination register is written with the source shifted as much as possible without overflow and an integer-overflow fault is signaled.

**shri** performs a conventional arithmetic shift right operation by shifting the sign bit in from the most significant bit. However, when this instruction is used to divide a negative integer operand by the power of 2, it may produce an incorrect quotient. (Discarding the bits shifted out has the effect of rounding the result toward negative.)

**shrdi** is provided for dividing integers by the power of 2. With this instruction, 1 is added to the result if the bits shifted out are non-zero and the operand is negative, which produces the correct result for negative operands. **shli** and **shrdi** are equivalent to **muli** and **divi** by the power of 2, respectively.

**rotate** rotates operand bits to the left (toward higher significance) by a specified number of bits. Bits shifted beyond register's left boundary (bit 31) appear at the right boundary (bit 0).

**eshro** is an i960 Cx processor-specific extension to the i960 processor family's instruction set. This instruction performs an ordinal right shift of a source register pair (64 bits) by as much as 32 bits and stores the result in a single (32-bit) register. This instruction is equivalent to an extended divide by a power of 2, which produces no remainder. The instruction is also the equivalent of a 64-bit extract of 32 bits.

## INSTRUCTION SET SUMMARY

**4.2.3 Logical**

These instructions perform bitwise Boolean operations on the specified operands:

|               |                                     |
|---------------|-------------------------------------|
| <b>and</b>    | <i>src2</i> AND <i>src1</i>         |
| <b>notand</b> | (NOT <i>src2</i> ) AND <i>src1</i>  |
| <b>andnot</b> | <i>src2</i> AND (NOT <i>src1</i> )  |
| <b>xor</b>    | <i>src2</i> XOR <i>src1</i>         |
| <b>or</b>     | <i>src2</i> OR <i>src1</i>          |
| <b>nor</b>    | NOT ( <i>src2</i> OR <i>src1</i> )  |
| <b>xnor</b>   | <i>src2</i> XNOR <i>src1</i>        |
| <b>not</b>    | NOT <i>src1</i>                     |
| <b>notor</b>  | (NOT <i>src2</i> ) or <i>src1</i>   |
| <b>ornot</b>  | <i>src2</i> or (NOT <i>src1</i> )   |
| <b>nand</b>   | NOT ( <i>src2</i> AND <i>src1</i> ) |

These all use the REG format and can specify literals or local, global or special function registers.

The processor provides logical operations in addition to **and**, **or** and **xor** as a performance optimization. This optimization reduces the number of instructions required to perform a logical operation and reduces the number of registers and instructions associated with bitwise mask storage and creation.

**4.2.4 Bit and Bit Field**

These instructions perform operations on a specified bit or bit field in an ordinal operand. All use the REG format and can specify literals or local, global or special function registers.

**4.2.4.1 Bit Operations**

These instructions operate on a specified bit:

|                 |               |
|-----------------|---------------|
| <b>setbit</b>   | set bit       |
| <b>clrbit</b>   | clear bit     |
| <b>notbit</b>   | not bit       |
| <b>alterbit</b> | alter bit     |
| <b>scanbit</b>  | scan for bit  |
| <b>spanbit</b>  | span over bit |

**setbit**, **clrbit** and **notbit** set, clear or complement (toggle) a specified bit in an ordinal.





**alterbit** alters the state of a specified bit in an ordinal according to the condition code. If the condition code is 010, the bit is set; if the condition code is 000, the bit is cleared.

**chkbit**, described in section 4.2.6, “Comparison” (pg. 4-12), can be used to check the value of an individual bit in an ordinal.

**scanbit** and **spanbit** find the most significant set bit or clear bit, respectively, in an ordinal.

#### 4.2.4.2 Bit Field Operations

The two bit field instructions are **extract** and **modify**.

**extract** converts a specified bit field, taken from an ordinal value, into an ordinal value. In essence, this instruction shifts right a bit field in a register and fills in the bits to the left of the bit field with zeros. (**eshro** also provides the equivalent of a 64-bit extract of 32 bits).

**modify** copies bits from one register, under control of a mask, into another register. Only unmasked bits in the destination register are modified. **modify** is equivalent to a bit field move.

An application that uses little-endian memory regions may need to access 32-bit big-endian data. The i960 Cx processors do not have a byte swap instruction; however, a byte swap can be performed in five clocks by use of the **modify** and **rotate** instructions. Example 4-1 shows assembly language instructions that can be used in assembly language programs or in programs written in high level languages that support in-line assembly code, such as the GNU960 and Intel C-tools C compilers.

**Example 4-1. Byte Swap**

```

/* Assume g0 contains value to swap; result written to r3. */
rotate    16,g0,r3
ldconst   0xff00ff00,r4
modify    r4,g0,r3
rotate    8,r3,r3
    
```

For example, if register g0 contains 0x12345678, the final result in r3 should be 0x78563412 after the byte swap. The following shows how each instruction works in this example.

|         | Instruction   | g0         | r3         |
|---------|---------------|------------|------------|
| rotate  | 16,g0,r3      | 0x12345678 | 0x56781234 |
| ldconst | 0xff00ff00,r4 | 0x12345678 | 0x56781234 |
| modify  | r4,g0,r3      | 0x12345678 | 0x12785634 |
| rotate  | 8,r3,r3       | 0x12345678 | 0x78563412 |



## INSTRUCTION SET SUMMARY

**4.2.5 Byte Operations**

**scanbyte** performs a byte-by-byte comparison of two ordinals to determine if any two corresponding bytes are equal. The condition code is set based on the results of the comparison. **scanbyte** uses the REG format and can specify literals or local, global or special function registers.

**4.2.6 Comparison**

The processor provides several types of instructions for comparing two operands, as described in the following subsections.

**4.2.6.1 Compare and Conditional Compare**

These instructions compare two operands then set the condition code bits in the AC register according to the results of the comparison:

|                |                             |
|----------------|-----------------------------|
| <b>cmpi</b>    | compare integer             |
| <b>cmpo</b>    | compare ordinal             |
| <b>concmpi</b> | conditional compare integer |
| <b>concmpo</b> | conditional compare ordinal |
| <b>chkbit</b>  | check bit                   |

These all use the REG format and can specify literals or local, global or special function registers. The condition code bits are set to indicate whether one operand is less than, equal to or greater than the other operand. See section 2.6.2, “Arithmetic Controls (AC) Register” (pg. 2-15) for a description of the condition codes for conditional operations.

**cmpi** and **cmpo** simply compare the two operands and set the condition code bits accordingly. **concmpi** and **concmpo** first check the status of condition code bit 2:

- If not set, the operands are compared as with **cmpi** and **cmpo**.
- If set, no comparison is performed and the condition code flags are not changed.

The conditional-compare instructions are provided specifically to optimize two-sided range comparisons to check if A is between B and C (i.e.,  $B \leq A \leq C$ ). Here, a compare instruction (**cmpi** or **cmpo**) checks one side of the range (e.g.,  $A \geq B$ ) and a conditional compare instruction (**concmpi** or **concmpo**) checks the other side (e.g.,  $A \leq C$ ) according to the result of the first comparison. The condition codes following the conditional comparison directly reflect the results of both comparison operations. Therefore, only one conditional branch instruction is required to act upon the range check; otherwise, two branches would be needed.

**chkbit** checks a specified bit in a register and sets the condition code flags according to the bit state. The condition code is set to  $010_2$  if the bit is set and  $000_2$  otherwise.



#### 4.2.6.2 Compare and Increment or Decrement

These instructions compare two operands, set the condition code bits according to the results, then increment or decrement one of the operands:

|                |                               |
|----------------|-------------------------------|
| <b>cmpinci</b> | compare and increment integer |
| <b>cmpinco</b> | compare and increment ordinal |
| <b>cmpdeci</b> | compare and decrement integer |
| <b>cmpdeco</b> | compare and decrement ordinal |

4

These all use the REG format and can specify literals or local, global or special function registers. They are an architectural performance optimization which allows two register operations (e.g., compare and add) to execute in a single cycle. These are intended for use at the end of iterative loops.

#### 4.2.6.3 Test Condition Codes

These test instructions allow the state of the condition code flags to be tested:

|               |                           |
|---------------|---------------------------|
| <b>teste</b>  | test for equal            |
| <b>testne</b> | test for not equal        |
| <b>testl</b>  | test for less             |
| <b>testle</b> | test for less or equal    |
| <b>testg</b>  | test for greater          |
| <b>testge</b> | test for greater or equal |
| <b>testo</b>  | test for ordered          |
| <b>testno</b> | test for unordered        |

If the condition code matches the instruction-specified condition, these cause a TRUE (01H) to be stored in a destination register; otherwise, a FALSE (00H) is stored. All use the COBR format and can operate on local, global and special function registers.

Since test instruction actions depend on a comparison, the architecture allows a programmer to predict the likely result of the operation for higher performance. The programmer's prediction is encoded in one bit of the opword. Intel 80960 assemblers encode the prediction with a mnemonic suffix of .t for true and .f for false. Refer to section A.2.7.7, "Branch Prediction" (pg. A-53).

#### 4.2.7 Branch

Branch instructions allow program flow direction to be changed by explicitly modifying the IP. The processor provides three branch instruction types:

- unconditional branch
- conditional branch
- compare and branch

## INSTRUCTION SET SUMMARY

Most branch instructions specify the target IP by specifying a signed displacement to be added to the current IP. Other branch instructions specify the target IP's memory address, using one of the processor's addressing modes. This latter group of instructions is called extended addressing instructions (e.g., branch extended, branch-and-link extended).

Since branch instruction actions depend on the result of a previous comparison, the architecture allows a programmer to predict the likely result of the branch operation for higher performance. The programmer's prediction is encoded in one bit of the opword. The Intel 80960 assembler encodes the prediction with a mnemonic suffix of .t for true and .f for false.

### 4.2.7.1 Unconditional Branch

These instructions are used for unconditional branching:

|             |                          |
|-------------|--------------------------|
| <b>b</b>    | Branch                   |
| <b>bx</b>   | Branch Extended          |
| <b>bal</b>  | Branch and Link          |
| <b>balx</b> | Branch and Link Extended |

**b** and **bal** use the CTRL format. **bx** and **balx** use the MEM format and can specify local or global registers as operands. **b** and **bx** cause program execution to jump to the specified target IP. These two instructions perform the same function; however, their determination of the target IP differs. The target IP of a **b** instruction is specified at link time as a relative displacement from the current IP. The target IP of the **bx** instruction is the absolute address resulting from the instruction's use of a memory addressing mode during execution.

**bal** and **balx** store the next instruction's address in a specified register, then jump to the specified target IP. (For **bal**, the RIP is automatically stored in register g14; for **balx**, the RIP location is specified with an instruction operand.) As described in section 5.9, "BRANCH-AND-LINK" (pg. 5-18), branch and link instructions provide a method of performing procedure calls that do not use the processor's integrated call/return mechanism. Here, the saved instruction address is used as a return IP. Branch and link is generally used to call leaf procedures (that is, procedures that do not call other procedures).

**bx** and **balx** can make use of any memory addressing mode.



#### 4.2.7.2 Conditional Branch

With conditional branch (**BRANCH IF**) instructions, the processor checks the AC register condition code flags. If these flags match the value specified with the instruction, the processor jumps to the target IP. These instructions use the displacement-plus-IP method of specifying the target IP:

|                    |                            |
|--------------------|----------------------------|
| <b>be</b> {.t .f}  | branch if equal/true       |
| <b>bne</b> {.t .f} | branch if not equal        |
| <b>bl</b> {.t .f}  | branch if less             |
| <b>ble</b> {.t .f} | branch if less or equal    |
| <b>bg</b> {.t .f}  | branch if greater          |
| <b>bge</b> {.t .f} | branch if greater or equal |
| <b>bo</b> {.t .f}  | branch if ordered          |
| <b>bno</b> {.t .f} | branch if unordered/false  |

4

All use the CTRL format. **bo** and **bno** are used with real numbers. Refer to section 2.6.2.2, “Condition Code” (pg. 2-16) for a discussion of the condition code for conditional operations.

#### 4.2.7.3 Compare and Branch

These instructions compare two operands then branch according to the comparison result. Three instruction subtypes are compare integer, compare ordinal and branch on bit:

|                          |  |
|--------------------------|--|
| <b>cmpibe</b> {.t   .f}  | compare integer and branch if equal            |
| <b>cmpibne</b> {.t   .f} | compare integer and branch if not equal        |
| <b>cmpibl</b> {.t   .f}  | compare integer and branch if less             |
| <b>cmpible</b> {.t   .f} | compare integer and branch if less or equal    |
| <b>cmpibg</b> {.t   .f}  | compare integer and branch if greater          |
| <b>cmpibge</b> {.t   .f} | compare integer and branch if greater or equal |
| <b>cmpibo</b> {.t   .f}  | compare integer and branch if ordered          |
| <b>cmpibno</b> {.t   .f} | compare integer and branch if unordered        |
| <b>cmpobe</b> {.t   .f}  | compare ordinal and branch if equal            |
| <b>cmpobne</b> {.t .f}   | compare ordinal and branch if not equal        |
| <b>cmpobl</b> {.t   .f}  | compare ordinal and branch if less             |
| <b>cmpoble</b> {.t   .f} | compare ordinal and branch if less or equal    |
| <b>cmpobg</b> {.t   .f}  | compare ordinal and branch if greater          |
| <b>cmpobge</b> {.t   .f} | compare ordinal and branch if greater or equal |
| <b>bbs</b> {.t   .f}     | check bit and branch if set                    |
| <b>bbc</b> {.t   .f}     | check bit and branch if clear                  |

## INSTRUCTION SET SUMMARY

All use the COBR machine instruction format and can specify literals, local, global and special function registers as operands. With compare ordinal and branch and compare integer and branch instructions, two operands are compared and the condition code bits are set as described in section 4.2.6, “Comparison” (pg. 4-12). A conditional branch is then executed as with the conditional branch (**BRANCH IF**) instructions.

With check bit and branch instructions, one operand specifies a bit to be checked in the other operand. The condition code flags are set according to the state of the specified bit: 010 (true) if the bit is set and 000 (false) if the bit is clear. A conditional branch is then executed according to condition code bit settings.

These instructions optimize execution performance time. When it is not possible to separate adjacent compare and branch instructions with other unrelated instructions, replacing two instructions with a single compare and branch instruction increases performance.

#### 4.2.8 Call and Return

The processor offers an on-chip call/return mechanism for making procedure calls. Refer to section 5.2, “CALL AND RETURN MECHANISM” (pg. 5-2). These instructions support this mechanism:

|              |               |
|--------------|---------------|
| <b>call</b>  | call          |
| <b>callx</b> | call extended |
| <b>calls</b> | call system   |
| <b>ret</b>   | return        |

**call** and **ret** use the CTRL machine-instruction format. **callx** uses the MEM format and can specify local or global registers. **calls** uses the REG format and can specify local, global or special function registers.

**call** and **callx** make local calls to procedures. A local call is a call that does not require a switch to another stack. **call** and **callx** differ only in the method of specifying the target procedure’s address. The target procedure of a call is determined at link time and is encoded in the opword as a signed displacement relative to the call IP. **callx** specifies the target procedure as an absolute 32-bit address calculated at run time using any one of the addressing modes. For both instructions, a new set of local registers and a new stack frame are allocated for the called procedure.

**calls** is used to make calls to system procedures — procedures that provide a kernel or system-executive services. This instruction operates similarly to **call** and **callx**, except that it gets its target-procedure address from the system procedure table. An index number included as an operand in the instruction provides an entry point into the procedure table.



Depending on the type of entry being pointed to in the system procedure table, **calls** can cause either a system-supervisor call or a system-local call to be executed. A system-supervisor call is a call to a system procedure that also switches the processor to supervisor mode and the supervisor stack. A system-local call is a call to a system procedure that does not cause an execution mode or stack change. Supervisor mode is described throughout CHAPTER 5, PROCEDURE CALLS.

**ret** performs a return from a called procedure to the calling procedure (the procedure that made the call). **ret** obtains its target IP (return IP) from linkage information that was saved for the calling procedure. **ret** is used to return from all calls — including local and supervisor calls — and from implicit calls to interrupt and fault handlers.

#### 4.2.9 Conditional Faults

Generally, the processor generates faults automatically as the result of certain operations. Fault handling procedures are then invoked to handle various fault types without explicit intervention by the currently running program. These conditional fault instructions permit a program to explicitly generate a fault according to the state of the condition code flags.

|                       |                           |
|-----------------------|---------------------------|
| <b>faulte{.t .f}</b>  | fault if equal            |
| <b>faultne{.t .f}</b> | fault if not equal        |
| <b>faultl{.t .f}</b>  | fault if less             |
| <b>faultle{.t .f}</b> | fault if less or equal    |
| <b>faultg{.t .f}</b>  | fault if greater          |
| <b>faultge{.t .f}</b> | fault if greater or equal |
| <b>faulto{.t .f}</b>  | fault if ordered          |
| <b>faultno{.t .f}</b> | fault if unordered        |

All use the CTRL format. Since the actions of these instructions are dependent upon the result of a previous comparison, the architecture allows a programmer to predict the likely result of the conditional fault instructions for higher performance. The programmer's prediction is encoded in one bit of the opword. The Intel 80960 assembler encodes the prediction with a mnemonic suffix of .t for true and .f for false.

#### 4.2.10 Debug

The processor supports debugging and monitoring of program activity through the use of trace events. These instructions support these debugging and monitoring tools:

|              |                         |
|--------------|-------------------------|
| <b>modpc</b> | modify process controls |
| <b>modtc</b> | modify trace controls   |
| <b>mark</b>  | mark                    |
| <b>fmark</b> | force mark              |

## INSTRUCTION SET SUMMARY

These all use the REG format. Trace functions are controlled with bits in the Trace Control (TC) register which enable or disable various types of tracing. Other TC register flags indicate when an enabled trace event is detected. Refer to CHAPTER 8, TRACING AND DEBUGGING.

**modpc** can enable/disable trace fault generation; **modtc** permits trace controls to be modified. **mark** causes a breakpoint trace event to be generated if breakpoint trace mode is enabled. **fmark** generates a breakpoint trace independent of the state of the breakpoint trace mode bits.

The i960 Cx processor-specific **sysctl** instruction, described in section 4.3, “SYSTEM CONTROL FUNCTIONS” (pg. 4-19), also provides control over breakpoint trace event generation. This instruction is used, in part, to load and control the i960 Cx microprocessors’ breakpoint registers.

### 4.2.11 Atomic Instructions

Atomic instructions perform read-modify-write operations on operands in memory. They allow a system to ensure that, when an atomic operation is performed on a specified memory location, the operation completes before another agent is allowed to perform an operation on the same memory. These instructions are required to enable synchronization between interrupt handlers and background tasks in any system. They are also particularly useful in systems where several agents — processors, coprocessors or external logic — have access to the same system memory for communication.

The atomic instructions are atomic add (**atadd**) and atomic modify (**atmod**). **atadd** causes an operand to be added to the value in the specified memory location. **atmod** causes bits in the specified memory location to be modified under control of a mask. Both instructions use the REG format and can specify literals or local, global or special function registers.

### 4.2.12 Processor Management

These instructions control processor-related functions:

|                 |  |
|-----------------|--|
| <b>modpc</b>    | modify the process controls register           |
| <b>flushreg</b> | flush cached local register sets to memory     |
| <b>modac</b>    | modify the AC register                         |
| <b>sysctl</b>   | perform system control function                |
| <b>sdma</b>     | set up a DMA controller channel                |
| <b>udma</b>     | copy current DMA pointers to internal data RAM |

All use the REG format and can specify literals or local, global or special function registers.

**modpc** provides a method of reading and modifying PC register contents. Only programs operating in supervisor mode may modify the PC register; however, any program may read it.





The processor provides a flush local registers instruction (**flushreg**) to save the contents of the cached local registers to the stack. The flush local registers instruction automatically stores the contents of all the local register sets — except the current set — in the register save area of their associated stack frames.

The modify arithmetic controls instruction (**modac**) allows the AC register contents to be copied to a register and/or modified under the control of a mask. The AC register cannot be explicitly addressed with any other instruction; however, it is implicitly accessed by instructions that use the condition codes or set the integer overflow flag.

4

**sysctl** is an i960 Cx processor-specific extension to the i960 family's instruction set which is used to configure the on-chip bus controller, interrupt controller, breakpoint registers and instruction cache. It also permits software to signal an interrupt or cause a processor reset and reinitialization. **sysctl** may only be executed by programs operating in supervisor mode.

**sdma** and **udma** are i960 Cx processor-specific extensions to the i960 family's instruction set which configure and monitor the on-chip DMA controller. These instructions may only be executed by programs operating in supervisor mode. Refer to CHAPTER 9, INSTRUCTION SET REFERENCE and CHAPTER 13, DMA CONTROLLER for a description of these instructions.

### 4.3 SYSTEM CONTROL FUNCTIONS

System control functions are a group of operations specific to the i960 Cx processor. These operations are performed by issuing the system control (**sysctl**) instruction. **sysctl** is a general-purpose instruction which performs a variety of functions. A message type field — an operand of the instruction — determines which function is performed. The system control functions include posting interrupts, configuring the instruction cache, invalidating the instruction cache, software reinitialization and loading control registers.

#### 4.3.1 **sysctl** Instruction Syntax

**sysctl** instruction syntax is generalized because the function of the operands differ, depending on message type selection. As shown in Figure 4-2, the instruction takes three source operands. The message type field is always the second byte of the source 1 operand. The instruction's generalized operand fields — designated as fields 1 through 4 — are interpreted differently or may not be used depending on the function selected in the message type field (see Table 4-3).

**sysctl** is a supervisor-only instruction. Executing this instruction while in user mode generates the type-mismatch fault.

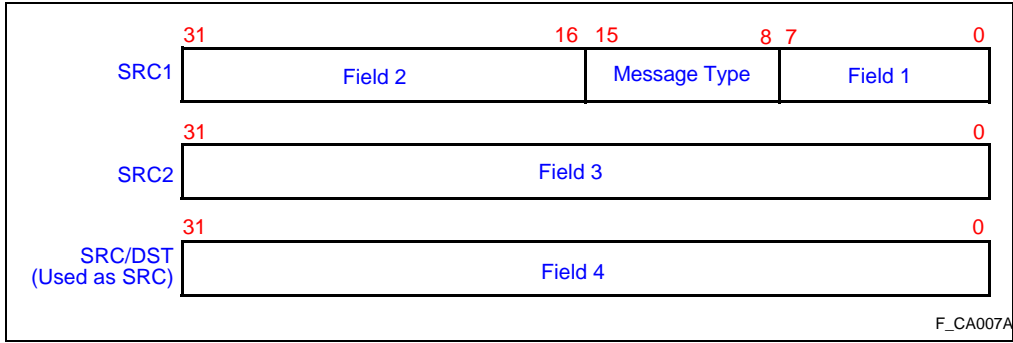


Figure 4-2. Source Operands for sysctl

Table 4-3. System Control Message Types and Operand Fields

| Message               | SRC1 |                         |         | SRC2                         | SRC3         |
|-----------------------|------|-------------------------|---------|------------------------------|--------------|
|                       | Type | Field 1                 | Field 2 | Field 3                      | Field 4      |
| Request Interrupt     | 00H  | vector #                | unused  | unused                       | unused       |
| Invalidate Cache      | 01H  | unused                  | unused  | unused                       | unused       |
| Configure Cache       | 02H  | Mode<br>(see Table 4-4) | unused  | Cache load<br>address        | unused       |
| Reinitialize          | 03H  | unused                  | unused  | first instruction<br>address | PRCB address |
| Load Control Register | 04H  | register group #        | unused  | unused                       | unused       |

**NOTE:** The processor ignores unused sources and fields.

### 4.3.2 System Control Messages

The five system control messages, defined in the following subsections, are:

- request interrupt: causes an interrupt to be serviced or posted.
- configure instruction cache: disables or locks instructions in a portion of the instruction cache.
- invalidate instruction cache: causes the contents of the instruction to be purged.
- reinitialize: restarts the processor.
- load control register: loads the on-chip control registers.



#### 4.3.2.1 Request Interrupt

Executing **sysctl** with a message type of 00H causes an interrupt to be requested. Field 1 of the instruction specifies the vector number of the interrupt requested. The remaining fields are not defined. Requesting an interrupt with **sysctl** causes the following actions to occur:

- The core performs an atomic write to the interrupt table and sets the bits in the pending interrupts and pending priorities fields that correspond to the requested interrupt. This action posts the software-requested interrupt.
- The core updates the software priority register with the value of the highest pending priority from the interrupt table. This may be the priority of the interrupt which was just posted. This action causes the interrupt to be serviced if its priority is greater than the current process priority or equal to 31.

4

Requesting an interrupt with a priority = 0 causes the interrupt table to be checked for posted interrupts. See section 6.5, “REQUESTING INTERRUPTS” (pg. 6-6) for information about software-requested interrupts.

#### 4.3.2.2 Invalidate Instruction Cache

Executing **sysctl** with a message type of 01H invalidates all cache entries. This mode clears all valid cache bits. After the operation, the cache is updated normally as misses occur. The mode is provided to allow a program to load or modify program space; it ensures that instructions are fetched from the modified space and not the cache.

#### 4.3.2.3 Configure Instruction Cache

The i960 CA processor contains an instruction cache which supports pre-load and lock of either none, half, or all of the instruction cache. However, only interrupt procedures can be locked into the cache. The i960 CF processor cache locking scheme has fewer restrictions: any section of code can be locked into half of the instruction cache — not just the interrupt procedures.

Executing **sysctl** with a message type of 02H selects cache mode. One of four cache modes are selected with the configure instruction cache message:

- normal cache
- load and lock half the cache
- load and lock entire cache
- cache disabled

The **sysctl** field 1 value determines which configure cache operation is performed (see Table 4-4). Field 3 is a word-aligned 32-bit address when a load and lock mode is selected; otherwise, this field is ignored. Text following the table further defines the modes.

Table 4-4. Cache Configuration Modes

| Mode Field       | Mode Description   | 80960CA              | 80960CF               |
|------------------|--|----------------------|-----------------------|
| 000 <sub>2</sub> | normal cache enabled   | 1 Kbyte              | 4 Kbytes              |
| XX1 <sub>2</sub> | full cache disabled  | 1 Kbyte              | 4 Kbytes              |
| 100 <sub>2</sub> | Load and lock full cache (execute off-chip)                        | 1 Kbyte <sup>1</sup> | 4 Kbytes <sup>2</sup> |
| 110 <sub>2</sub> | Load and lock half the cache;<br>remainder is normal cache enabled | 512 bytes            | 2 Kbytes              |
| 010 <sub>2</sub> | Reserved   | 1 Kbyte              | 4 Kbytes              |

**NOTES:**

1. On the CA, only interrupt procedures can execute in the locked portion of the cache.
2. On the CF, interrupt procedures and other code can operate in the locked portion of the cache.

Mode 000<sub>2</sub> configures the cache as two way set associative. Mode XX1<sub>2</sub> completely disables the cache. Either of these cache configurations can be specified when the processor initializes by programming the Cache Configuration Word in the PRCB. See section 14.2.6, “Process Control Block (PRCB)” (pg. 14-8). The modes allow the cache to be turned off temporarily to aid in debugging.

When the cache is disabled, the processor depends on a 16 word instruction buffer to provide decoding instructions. The instruction buffer operates as a small cache, organized as two sets of two way set associative cache, with a four word line size. When the main cache is disabled, small code loops may still execute entirely within the instruction buffer.

Modes 100<sub>2</sub> and 110<sub>2</sub> select cache load-and-lock options. These modes determine whether half or all of the cache is loaded with instructions and locked against further updates. The **sysctl** instruction’s field 3 must contain an address; this address points to a quad-word aligned block of memory in the external address space. Instructions starting at this address are loaded into the cache. These instructions can only be accessed by selected interrupts which vector to these instructions’ addresses. The load-and-lock mechanism selectively optimizes latency and throughput for interrupts.

#### 4.3.2.4 Reinitialize Processor

Executing **sysctl** with message type 03H reinitializes the processor. **sysctl** fields 3 and 4 must contain, respectively, the First Instruction Pointer and the PRCB Pointer. Reinitialization bypasses the i960 Cx processors’ built-in self-test. The PRCB is processed and the processor branches to the first instruction. See section 14.2, “INITIALIZATION” (pg. 14-2) for a complete description of the processor reinitialization steps.



The reinitialize message is useful for changing the Initial Memory Image. For example, at initialization, the interrupt table is moved to RAM so the interrupts may be posted in the table's pending interrupts and priorities fields. In this case, the reinitialize message specifies a new PRCB which contains a pointer to the new interrupt table in RAM. See section 14.3.1, "Reinitializing and Relocating Data Structures" (pg. 14-11).

#### 4.3.2.5 Load Control Registers

Executing **sysctl** with message type 04H causes the on-chip control registers to be loaded with data from external memory. Each **sysctl** invocation causes four words from the Control Register Table in external memory to be read and then placed in their respective internal control registers. Field 1 must contain the number of the register group to be loaded. Table 4-5 shows the register group number and the registers represented in the Control Register Table.

At initialization, or when the processor is reinitialized, all groups in the control table are automatically loaded into the on-chip control registers.

Table 4-5. Control Register Table and Register Group Numbers

| Group | Byte Offset in Table | Control Register Loaded                 |
|-------|----------------------|---|
| 00H   | 00H                  | Data Address Breakpoint 0 (DAB0)        |
|       | 04H                  | IP Breakpoint Register 0 (IPB0)         |
|       | 08H                  | IP Breakpoint Register 1 (IPB1)         |
| 01H   | 0CH                  | Data Address Breakpoint 1 (DAB1)        |
|       | 10H                  | Interrupt Map Register 0 (IMAP0)        |
|       | 14H                  | Interrupt Map Register 1 (IMAP1)        |
|       | 18H                  | Interrupt Map Register 2 (IMAP2)        |
|       | 1CH                  | Interrupt Control Register (ICON)       |
| 02H   | 20H                  | Memory Region 0 Configuration (MCON0)   |
|       | 24H                  | Memory Region 1 Configuration (MCON1)   |
|       | 28H                  | Memory Region 2 Configuration (MCON2)   |
|       | 2CH                  | Memory Region 3 Configuration (MCON3)   |
| 03H   | 30H                  | Memory Region 4 Configuration (MCON4)   |
|       | 34H                  | Memory Region 5 Configuration (MCON5)   |
|       | 38H                  | Memory Region 6 Configuration (MCON6)   |
|       | 3CH                  | Memory Region 7 Configuration (MCON7)   |
| 04H   | 40H                  | Memory Region 8 Configuration (MCON8)   |
|       | 44H                  | Memory Region 9 Configuration (MCON9)   |
|       | 48H                  | Memory Region 10 Configuration (MCON10) |
|       | 4CH                  | Memory Region 11 Configuration (MCON11) |
| 05H   | 50H                  | Memory Region 12 Configuration (MCON12) |
|       | 54H                  | Memory Region 13 Configuration (MCON13) |
|       | 58H                  | Memory Region 14 Configuration (MCON14) |
|       | 5CH                  | Memory Region 15 Configuration (MCON15) |
| 06H   | 60H                  | Reserved                                |
|       | 64H                  | Breakpoint Control Register (BPCON)     |
|       | 68H                  | Trace Controls Register (TC)            |
|       | 6CH                  | Bus Configuration Control (BCON)        |

# PROCEDURE CALLS





## CHAPTER 5 PROCEDURE CALLS

This chapter describes mechanisms for making procedure calls, which include branch-and-link instructions, built-in call and return mechanism, call instructions (**call**, **callx**, **calls**), return instruction (**ret**) and call actions caused by interrupts and faults.

### 5.1 OVERVIEW

**5**

The i960<sup>®</sup> architecture supports two methods for making procedure calls:

- A RISC-style branch-and-link: a fast call best suited for calling procedures that do not call other procedures.
- An integrated call and return mechanism: a more versatile method for making procedure calls, providing a highly efficient means for managing a large number of registers and the program stack.

On a branch-and-link (**bal**, **balx**), the processor branches and saves a return IP in a register. The called procedure uses the same set of registers and the same stack as the calling procedure. On a call (**call**, **callx**, **calls**) or when an interrupt or fault occurs, the processor also branches to a target instruction and saves a return IP. Additionally, the processor saves the local registers and allocates a new set of local registers and a new stack for the called procedure. The saved context is restored when the return instruction (**ret**) executes.

In many RISC architectures, a branch-and-link instruction is used as the base instruction for coding a procedure call. The user program then handles register and stack management for the call. Since the i960 architecture provides a fully integrated call and return mechanism, coding calls with branch-and-link is not necessary. Additionally, the integrated call is much faster than typical RISC-coded calls.

The branch-and-link instruction in the i960 processor family, therefore, is used primarily for calling leaf procedures. Leaf procedures call no other procedures. They are called “leaf procedures” because they reside at the “leaves” of the call tree.

In the i960 architecture the integrated call and return mechanism is used in two ways:

- explicit calls to procedures in a user’s program
- implicit calls to interrupt and fault handlers

The remainder of this chapter explains the generalized call mechanism used for explicit and implicit calls and call and return instructions.

## PROCEDURE CALLS

The processor performs two call actions:

|                   |  |
|-------------------|--|
| <i>local</i>      | When a local call is made, execution mode remains unchanged and the stack frame for the called procedure is placed on the <i>local stack</i> . The local stack refers to the stack of the calling procedure. |
| <i>supervisor</i> | When a supervisor call is made, execution mode is switched to supervisor and the stack frame for the called procedure is placed on the <i>supervisor stack</i> .   |

Explicit procedure calls can be made using several instructions. Local call instructions **call** and **callx** perform a local call action. With **call** and **callx**, the called procedure's IP is included as an operand in the instruction.

A system call is made with **calls**. This instruction is similar to **call** and **callx**, except that the processor obtains the called procedure's IP from the *system procedure table*. A system call, when executed, is directed to perform either the local or supervisor call action. These calls are referred to as system-local and system-supervisor calls, respectively. A system-supervisor call is also referred to as a supervisor call.

## 5.2 CALL AND RETURN MECHANISM

At any point in a program, the i960 processor has access to the global registers, a local register set and the procedure stack. A subset of the stack allocated to the procedure is called the stack frame.

- When a call executes, a new stack frame is allocated for the called procedure. The processor also saves the current local register set, freeing these registers for use by the newly called procedure. In this way, every procedure has a unique stack and a unique set of local registers.
- When a return executes, the current local register set and current stack frame are deallocated. The previous local register set and previous stack frame are restored.

### 5.2.1 Local Registers and the Procedure Stack

The processor automatically allocates a set of 16 local registers for each procedure. Since local registers are on-chip, they provide fast access storage for local variables. Of the 16 local registers, 13 are available for general use; r0, r1 and r2 are reserved for linkage information to tie procedures together.

#### NOTE:

The processor does not always clear or initialize the set of local registers assigned to a new procedure. Therefore, initial register contents are unpredictable. Also, because the processor does not initialize the local register save area in the newly created stack frame for the procedure, its contents are equally unpredictable.



The procedure stack can be located anywhere in the address space and grows from low addresses to high addresses. It consists of contiguous frames, one frame for each active procedure. Local registers for a procedure are assigned a save area in each stack frame (Figure 5-1). The procedure stack, available to the user, begins after this save area.

To increase procedure call speed, the architecture allows an implementation to cache the saved local register sets on-chip. Thus, when a procedure call is made, the contents of the current set of local registers often does not have to be written out to the save area in the stack frame in memory. Refer to section 5.2.4, “Caching of Local Register Sets” (pg. 5-6) and section 5.2.5, “Mapping Local Registers to the Procedure Stack” (pg. 5-9) for more about local registers and procedure stack interrelations.

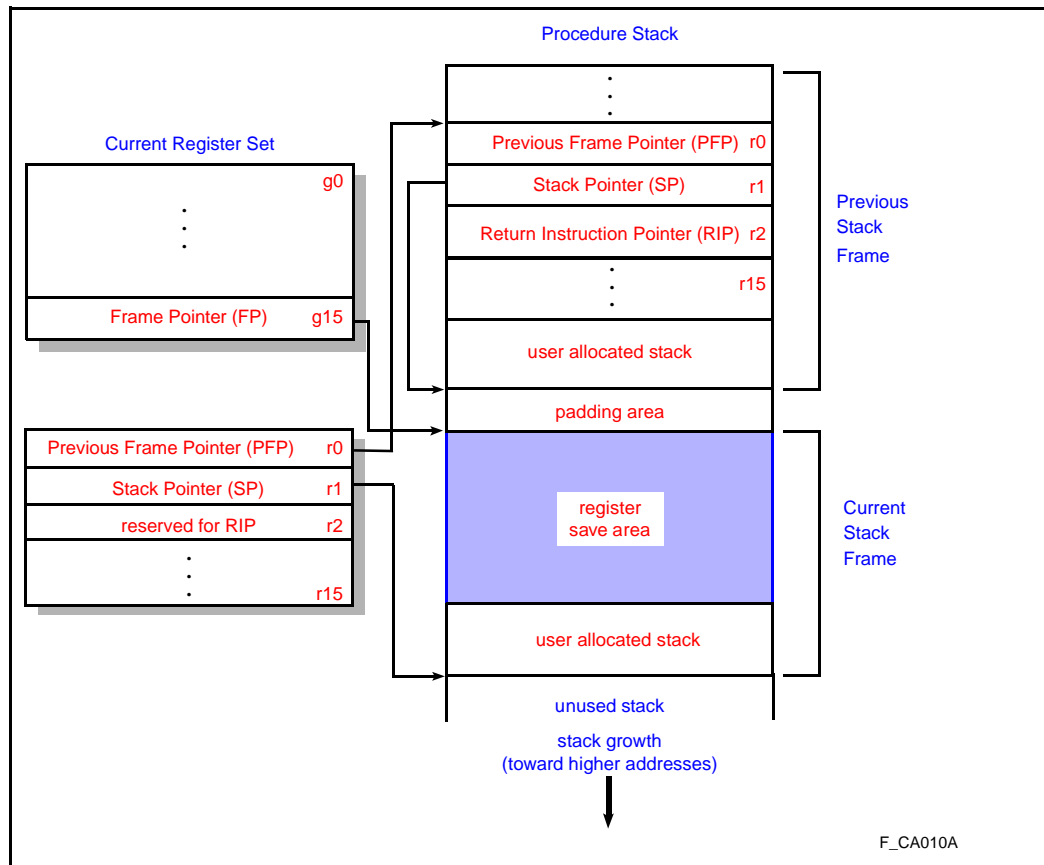


Figure 5-1. Procedure Stack Structure and Local Registers

## PROCEDURE CALLS

### 5.2.2 Local Register and Stack Management

Global register g15 (FP) and local registers r0 (PFP), r1 (SP) and r2 (RIP) contain information to link procedures together and link local registers to the procedure stack (Figure 5-1). The following subsections describe this linkage information.

#### 5.2.2.1 Frame Pointer

The frame pointer is the current stack frame's first byte address. It is stored in global register g15, the frame pointer (FP) register. The FP register is always reserved for the frame pointer; do not use g15 for general storage. In the i960 Cx processors, frames are aligned on 16-byte boundaries (Figure 5-1). When the processor creates a new frame on a procedure call — if necessary — it adds a padding area to the stack so that the new frame starts on a 16-byte alignment boundary.

Stack frame alignment is defined for each implementation of the i960 processor family. This alignment boundary is calculated from the relationship  $SALIGN * 16$ . For the i960 Cx processors,  $SALIGN = 1$  and stacks are aligned on 16-byte boundaries.

#### 5.2.2.2 Stack Pointer

The stack pointer is the byte-aligned address of the stack frame's next unused byte. The stack pointer value is stored in local register r1, the stack pointer (SP) register. The procedure stack grows upward (i.e., toward higher addresses). When a stack frame is created, the processor automatically adds 64 to the frame pointer value and stores the result in the SP register. This action creates the register save area in the stack frame for the local registers.

The user must modify the SP register value when data is stored or removed from the stack. The i960 architecture does not provide an explicit push or pop instruction to perform this action. This is typically done by adding the size of all pushes to the stack in one operation.

#### 5.2.2.3 Previous Frame Pointer

The previous frame pointer is the previous stack frame's first byte address. This address' upper 28 bits are stored in local register r0, the previous frame pointer (PFP) register. The four least-significant bits of the PFP are used to store the return-type field.

#### 5.2.2.4 Return Type Field

PFP register bits 0 through 3 contain return type information for the calling procedure. When a procedure call is made — either explicit or implicit — the processor records the call type in the return type field. The processor then uses this information to select the proper return mechanism when returning to the calling procedure. The use of this information is described section 5.8, "RETURNS" (pg. 5-16).



### 5.2.2.5 Return Instruction Pointer

When a call is made, the processor saves the address of the instruction after the call, providing a re-entry point when the return instruction is executed. This address is automatically stored in local register r2 of the calling frame. Register r2 is referred to as the return instruction pointer (RIP) register. The RIP register is a special register; do not use r2 to hold operand values. Since interrupts and faults trigger an implicit call action, the RIP register may be written at any time with the return pointer associated with the interrupt or fault event.

### 5.2.3 Call and Return Action

5

To clarify how procedures are linked and how the local register and stack are managed, the following sections describe a general call and return operation and the operations performed with the FP, SP, PFP and RIP registers described in the preceding sections.

The events for call and return operations are given in a logical order of operation. The i960 Cx processors can execute independent operations in parallel; therefore, many of these events execute simultaneously. For example, to improve performance, the processors often begin prefetch of the target instruction for the call or return before the operation is complete.

#### 5.2.3.1 Call Operation

When a **call** instruction is executed or an implicit call is triggered:

1. The processor stores the instruction pointer for the instruction following the call in the current stack's RIP register (r2).
2. The current local registers — including the PFP, SP and RIP registers — are saved, freeing these for use by the called procedure. Because saved local registers are cached on the i960 Cx processors, the registers are always saved in the on-chip local register cache at this time.
3. The frame pointer (g15) for the calling procedure is stored in the current stack's PFP register (r0). The return type field in the PFP register is set according to the call type which is performed. See section 5.8, "RETURNS" (pg. 5-16).
4. A new stack frame is allocated by using the stack pointer value saved in step 3. This value is first rounded to the next 16-byte boundary to create a new frame pointer, then stored in the FP register. Next, 64 bytes are added to create the new frame's register save area. This value is stored in the SP register.
5. The instruction pointer is loaded with the address of the first instruction in the called procedure. The processor gets the new instruction pointer from the **call**, the system procedure table, the interrupt table or the fault table, depending on the type of call executed.

Upon completion of these steps, the processor begins executing the called procedure.

## PROCEDURE CALLS

### 5.2.3.2 Return Operation

A return from any call type — explicit or implicit — is always initiated with a return (**ret**) instruction. On a return, the processor performs these operations:

1. The current stack frame and local registers are deallocated by loading the FP register with the value of the PFP register.
2. The local registers for the return target procedure are retrieved. The registers are usually read from the local register cache; however, in some cases, these registers have been flushed from register cache to memory and must be read directly from the save area in the stack frame.
3. The processor sets the instruction pointer to the value of the RIP register.

Upon completion of these steps, the processor executes the procedure to which it returns.

### 5.2.4 Caching of Local Register Sets

The i960 architecture provides a local register cache to improve call and return performance. Local registers are typically saved and restored from the local register cache when calls and returns are executed. For the i960 Cx microprocessors, movement of a local register set between local registers and cache takes only four clock cycles. Other overhead associated with a call or return is performed in parallel with this data movement.

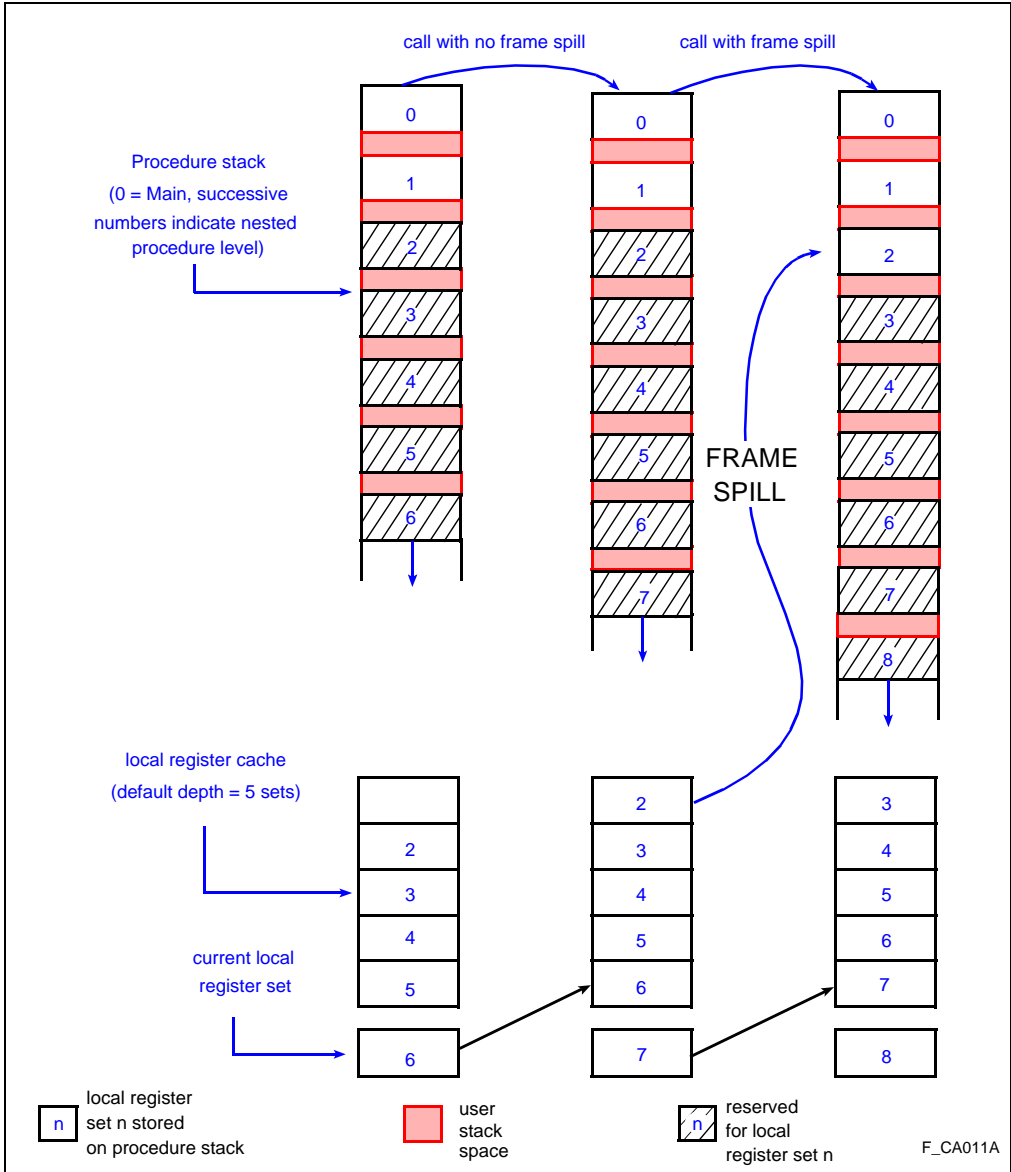
When the number of nested procedures exceeds local register cache size, local register sets must at times be saved or restored to their associated save areas in the procedure stack. Because these operations require access to external memory, this local cache miss impacts call and return performance.

When a call is made and the register cache is full, a register set in the cache must be saved to external memory to make room for the current set of local registers in the cache. This action is referred to as a frame spill. The oldest set of local registers stored in the cache is spilled to the associated local register save area in the procedure stack. Figure 5-2 illustrates a call operation with and without a frame spill.

Similarly, when a return is made and the local register set for the target procedure is not available in the cache, these local registers must be retrieved from the procedure stack in memory. This operation is referred to as a frame fill. Figure 5-3 illustrates a return operation with and without a frame fill.

Register cache size is specified at initialization by the register cache configuration word value in the PRCB. The i960 Cx register cache size is adjustable to hold from 1 to 14 sets of local registers. See section 14.2.6, “Process Control Block (PRCB)” (pg. 14-8) for more information about initialization and the PRCB.





5

Figure 5-2. Frame Spill

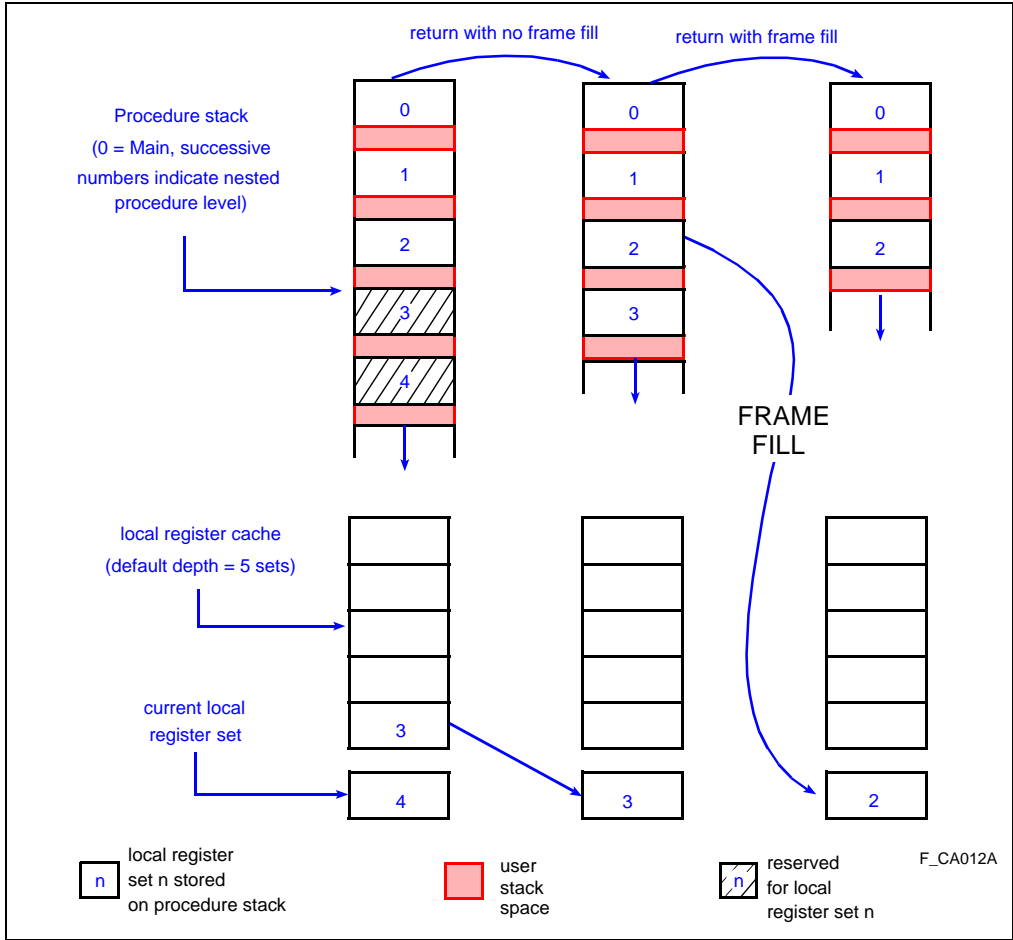


Figure 5-3. Frame Fill

Up to five local register sets are cached by default with no impact to the processor’s available resources. When the cache is configured for 6 to 14 sets, part of the internal data RAM is used to expand the cache. Data RAM usage begins at the highest address of internal RAM (03FFH) and grows downward.

As indicated in Table 5-1, the programmed value of the cache configuration word (CCW) in the PRCB determines the number of register sets cached and the amount of internal data RAM used.





**Table 5-1. PRCB Cache Configuration Word and Internal Data RAM**

| CCW Value                   | # of Cached Sets | Internal Data RAM Used (in bytes) |
|-----------------------------|------------------|-----------------------------------|
| 0                           | 1                | 0                                 |
| $1 \leq \text{CCW} \leq 5$  | CCW              | 0                                 |
| $6 \leq \text{CCW} \leq 15$ | CCW - 1          | $(\text{CCW} - 5) * 16$           |

Register cache cannot be disabled. Register cache size equals 1 when the cache configuration word is programmed to a value of 0. Also, a value of 5 or 6 produces the same cache number of cache sets; however, when programmed to 6, 16 bytes of internal data RAM is used; when programmed to 5, no internal data RAM is used.

5

The user program is responsible for preventing any corruption to the areas of internal RAM which are used for the register cache. In a typical program, most procedure calls and returns cause procedure depth to oscillate a few levels around a median call depth. The cache tends to be partially filled at the median call depth. Cache flushes occur when oscillations around the median depth are larger than the cache size can accommodate. Configuring local register cache to hold five sets of local registers avoids numerous cache fills and spills for most applications and does not use any of the data RAM which is available for general data storage. It is recommended to configure the cache for a minimum of five register sets.

### 5.2.5 Mapping Local Registers to the Procedure Stack

Each local register set is mapped to a register save area of its respective frame in the procedure stack (Figure 5-1). Saved local register sets are frequently cached on-chip rather than saved to memory. This caching is performed non-transparently. Local register set contents are not saved automatically to the save area in memory when the register set is cached. This would cause a significant performance loss for call operations.

Also, no automatic update policy is implemented for register cache. If the register save area in memory for a cached register set is modified, there is no guarantee that the modification will be reflected when the register set is restored. The set must be written (or flushed) to memory because of a frame spill prior to the modification for the modification to be valid.

**flushreg** causes the contents of all cached local register sets to be written (flushed) to their associated stack frames in memory. The register cache is then invalidated, meaning that all flushed register sets are restored from their save areas in memory. The current set of local registers is not written to memory. **flushreg** is commonly used in debuggers or fault handlers to gain access to all saved local registers. In this way, call history may be traced back through nested procedures. **flushreg** is also used when implementing task switches in multitasking kernels. The procedure stack is changed as part of the task switch. To change the procedure stack, **flushreg** is executed to update the current procedure stack and invalidate all entries in the local register cache. Next, the



## PROCEDURE CALLS

procedure stack is changed by directly modifying the FP and SP registers and executing a call operation. After **flushreg** executes, the procedure stack may also be changed by modifying the previous frame in memory and executing a return operation.

### NOTE:

When a set of local registers is assigned to a new procedure, the processor may or may not clear or initialize these registers. Therefore, initial register contents are unpredictable. Also, the processor does not initialize the local register save area in the newly created stack frame for the procedure; its contents are equally unpredictable.

### 5.3 PARAMETER PASSING

Parameters are passed between procedures in two ways:

|                  |   |
|------------------|---|
| <i>value</i>     | Parameters are passed directly to the calling procedure as part of the call and return mechanism. This is the fastest method of passing parameters. |
| <i>reference</i> | Parameters are stored in an argument list in memory and a pointer to the argument list is passed in a global register.                              |

When passing parameters by value, the calling procedure stores the parameters to be passed in global registers. Since the calling procedure and the called procedure share the global registers, the called procedure has direct access to the parameters after the call.

When a procedure needs to pass more parameters than will fit in the global registers, they can be passed by reference. Here, parameters are placed in an argument list and a pointer to the argument list is placed in a global register.

The argument list can be stored anywhere in memory; however, a convenient place to store an argument list is in the stack for a calling procedure. Space for the argument list is created by incrementing the SP register value. If the argument list is stored in the current stack, the argument list is automatically deallocated when no longer needed.

A procedure receives parameters from — and returns values to — other calling procedures. To do this successfully and consistently, all procedures must agree on the use of the global registers.

Parameter registers pass values into a function. Up to 12 parameters can be passed by value using the global registers. If the number of parameters exceeds 12, additional parameters are passed using the calling procedure's stack; a pointer to the argument list is passed in a pre-designated register. Similarly, several registers are set aside for return arguments and a return argument block pointer is defined to point to additional parameters. If the number of return arguments exceeds the



available number of return argument registers, the calling procedure passes a pointer to an argument list on its stack where the remaining return values will be placed. Example 5-1 illustrates parameter passing by value and reference.

Local registers are automatically saved when a call is made. Because of the local register cache, they are saved quickly and with no external bus traffic. The efficiency of the local register mechanism plays an important role in two cases when calls are made:

1. When a procedure is called which contains other calls, global parameter registers are moved to working local registers at the beginning of the procedure. In this way, parameter registers are freed and nested calls are easily managed. The register move instruction necessary to perform this action is very fast; the working parameters — now in local registers — are saved efficiently when nested calls are made.
2. When other procedures are nested within an interrupt or fault procedure, the procedure must preserve all normally non-preserved parameter registers. This is necessary because the interrupt or fault occurs at any point in the user's program and a return from an interrupt or fault must restore the exact processor state. The interrupt or fault procedure can move non-preserved global registers to local registers before the nested call.

5

#### Example 5-1. Parameter Passing Code Example

```
# Example of parameter passing . . .
# C-source:   int a,b[10];
#             a = procl(a,1,'x",&b[0]);
#             assembles to ...
      mov     r3,g0          # value of a
      ldconst 1,g1          # value of 1
      ldconst 120,g2       # value of "x"
      lda     0x40(fp),g3   # reference to b[10]
      call   _procl
      mov     g0,r3        #save return value in "a"
      :
      :
_procl:
      movq    g0,r4        # save parameters
      :
      :                  # other instructions in
procedure
      :                  # and nested calls
      mov     r3,g0       # load return parameter
      ret
```

## PROCEDURE CALLS

### 5.4 LOCAL CALLS

A local call does not cause a stack switch. A local call can be made two ways:

- with the **call** and **callx** instructions; or
- with a system-local call as described in section 5.5, “SYSTEM CALLS” (pg. 5-12).

**call** specifies the address of the called procedures as the IP plus a signed, 24-bit displacement (i.e.,  $-2^{23}$  to  $2^{23} - 4$ ). **callx** allows any of the addressing modes to be used to specify the procedure address. The IP-with-displacement addressing mode allows full 32-bit IP-relative addressing.

When a local call is made with a **call** or **callx**, the processor performs the same operation as described in section 5.2.3.1, “Call Operation” (pg. 5-5). The target IP for the call is derived from the instruction’s operands and the new stack frame is allocated on the current stack.

### 5.5 SYSTEM CALLS

A system call is a call made via the system procedure table. It can be used to make a system-local call — similar to a local call made with **call** and **callx** — or a system supervisor call.

A system call is initiated with **calls**, which requires a procedure number operand. The procedure number provides an index into the system procedure table, where the processor finds IPs for specific procedures.

Using an i960 processor language assembler, a system procedure is directly declared using the `.sysproc` directive. At link time, the optimized call directive, `callj`, is replaced with a **calls** when a system procedure target is specified. (Refer to current i960 processor assembler documents for a description of the `.sysproc` and `callj` directives.)

The system call mechanism offers two benefits. First, it supports application software portability. System calls are commonly used to call kernel services. By calling these services with a procedure number rather than a specific IP, applications software does not need to be changed each time the implementation of the kernel services is modified. Only the entries in the system procedure table must be changed.

Second, the ability to switch to a different execution mode and stack with a system supervisor call allows kernel procedures and data to be insulated from applications code. This benefit is further described in section 2.7, “USER SUPERVISOR PROTECTION MODEL” (pg. 2-20).



5.5.1 System Procedure Table

The system procedure table is a data structure for storing IPs to system procedures. These can be procedures which software can access through (1) a system call or (2) fault handling procedures, which the processor can access through its fault handling mechanism. Using the system procedure table to store IPs for fault handling is described in section 7.1, “FAULT HANDLING FACILITIES OVERVIEW” (pg. 7-1).

Figure 5-4 shows the system procedure table structure. It is 1088 bytes in length and can have up to 260 procedure entries. At initialization, the processor caches a pointer to the system procedure table. This pointer is located in the PRCB. The following subsections describe this table’s fields.

5

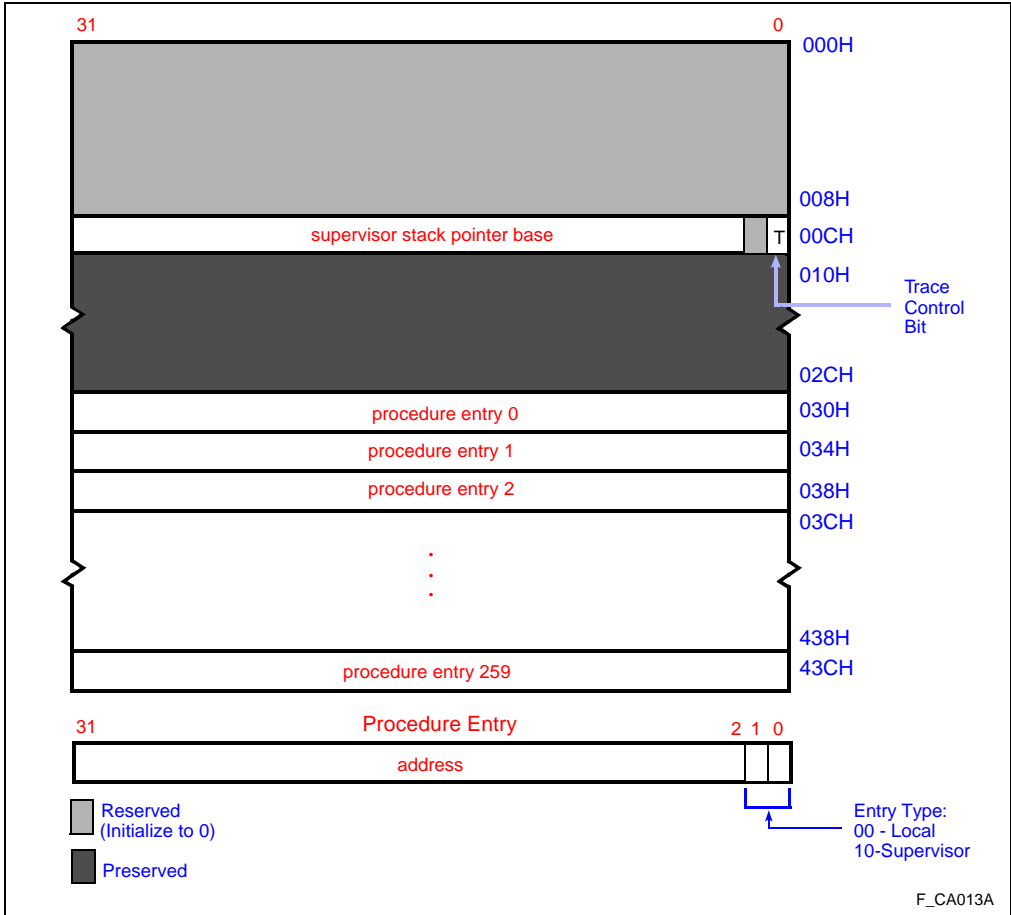


Figure 5-4. System Procedure Table

## PROCEDURE CALLS

### 5.5.1.1 Procedure Entries

A procedure entry in the system procedure table specifies a procedure's location and type. Each entry is one word in length and consists of an address (or IP) field and a type field. The address field gives the address of the first instruction of the target procedure. Since all instructions are word aligned, only the entry's 30 most significant bits are used for the address. The entry's two least-significant bits specify entry type. The procedure entry type field indicates call type: system-local call or system-supervisor call (Table 5-2). On a system call, the processor performs different actions depending on the type of call selected.

**Table 5-2. Encodings of Entry Type Field in System Procedure Table**

| Encoding | Call Type              |
|----------|------------------------|
| 000      | System-Local Call      |
| 001      | Reserved               |
| 010      | System-Supervisor Call |
| 011      | Reserved               |

### 5.5.1.2 Supervisor Stack Pointer

When a system-supervisor call is made, the processor switches to a new stack called the *supervisor stack*, if not already in supervisor mode. The processor gets a pointer to this stack from the supervisor stack pointer field in the system procedure table (Figure 5-4) during the reset initialization sequence and caches the pointer internally. Only the 30 most significant bits of the supervisor stack pointer are given. The processor aligns this value to the next 16 byte boundary to determine the first byte of the new stack frame.

### 5.5.1.3 Trace Control Bit

The trace control bit (byte 12, bit 0) specifies the new value of the trace enable bit in the PC register (PC.te) when a system-supervisor call causes a switch from user mode to supervisor mode. Setting this bit to 1 enables tracing in the supervisor mode; setting it to 0 disables tracing. The use of this bit is described in section 8.1.2, "Trace Enable Bit and Trace-Fault-Pending Flag" (pg. 8-3).



### 5.5.2 System Call to a Local Procedure

When a **calls** instruction references an entry in the system procedure table with an entry type of 00, the processor executes a system-local call to the selected procedure. The action that the processor performs is the same as described in section 5.2.3.1, “Call Operation” (pg. 5-5). The call’s target IP is taken from the system procedure table and the new stack frame is allocated on the current stack. The calls algorithm is described in section 9.3.12, “calls” (pg. 9-22).

### 5.5.3 System Call to a Supervisor Procedure

When a **calls** instruction references an entry in the system procedure table with an entry type of 010, the processor executes a system-supervisor call to the selected procedure. The call’s target IP is taken from the system procedure table.

5

The processor performs the same action as described in section 5.2.3.1, “Call Operation” (pg. 5-5), with the following exceptions:

- If the processor is in user mode, it switches to supervisor mode.
- The new frame for the called procedure is placed on the supervisor stack.
- If a mode switch occurs, the state of the trace enable bit in the PC register is saved in the return type field in the PFP register. The trace enable bit is then loaded from the trace control bit in the system procedure table.

When the processor switches to supervisor mode, it remains in that mode and creates new frames on the supervisor stack until a return is performed from the procedure that caused the original switch to supervisor mode. While in supervisor mode, either the local call instructions (**call** and **callx**) or **calls** can be used to call procedures.

The user-supervisor protection model and its relationship to the supervisor call are described in section 2.7, “USER SUPERVISOR PROTECTION MODEL” (pg. 2-20).

## 5.6 USER AND SUPERVISOR STACKS

When using the user-supervisor protection mechanism, the processor maintains separate stacks in the address space. One of these stacks—the user stack—is for procedures executed in user mode; the other stack—the supervisor stack—is for procedures executed in supervisor mode.

The user and supervisor stacks are identical in structure (Figure 5-1). The base stack pointer for the supervisor stack is automatically read from the system procedure table and cached internally at initialization or when the processor is reinitialized with **sysctl**. Each time a user-to-supervisor mode switch occurs, the cached supervisor stack pointer base is used for the starting point of the new supervisor stack. The base stack pointer for the user stack is usually created in the initial-

# PROCEDURE CALLS

ization code. See section 14.2, "INITIALIZATION" (pg. 14-2). The base stack pointers must be aligned to a 16-byte boundary; otherwise, the first frame pointer in the stack is rounded up to the next 16-byte boundary.

## 5.7 INTERRUPT AND FAULT CALLS

The architecture defines two types of implicit calls that make use of the call and return mechanism: interrupt handling procedure calls and fault handling procedure calls. A call to an interrupt procedure is similar to a system-supervisor call. Here, the processor obtains pointers to the interrupt procedures through the interrupt table. The processor always switches to supervisor mode on an interrupt procedure call.

A call to a fault procedure is similar to a system call. Fault procedure calls can be local calls or supervisor calls. The processor obtains pointers to fault procedures through the fault table and (optionally) through the system procedure table.

When a fault call or interrupt call is made, a fault record or interrupt record is placed in the newly generated stack frame for the call. These records hold the machine state and information to identify the fault or interrupt. When a return from an interrupt or fault is executed, machine state is restored from these records. See CHAPTER 7, FAULTS and CHAPTER 6, INTERRUPTS for more information on the structure of the fault and interrupt records.

## 5.8 RETURNS

The return (**ret**) instruction provides a generalized return mechanism that can be used to return from any procedure that was entered by **call**, **calls**, **callx**, an interrupt call or a fault call. When **ret** executes, the processor uses the information from the return-type field in the PFP register (Figure 5-5) to determine the type of return action to take.

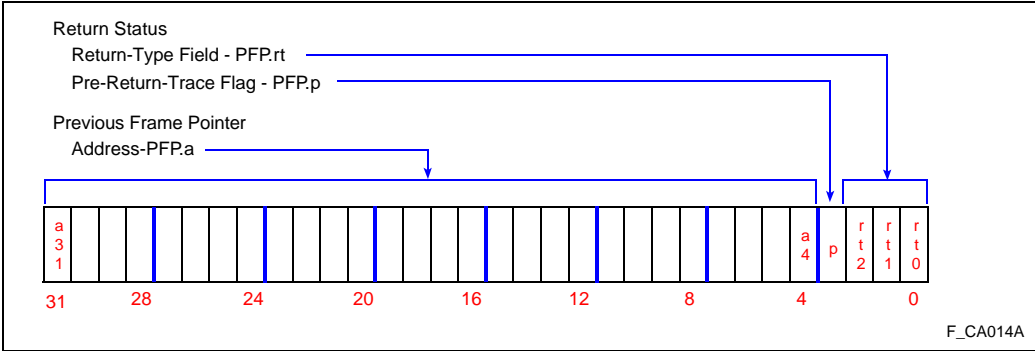


Figure 5-5. Previous Frame Pointer Register (PFP) (r0)





*return-type field* indicates the type of call which was made. Table 5-3 shows the return-type field encoding for the various calls: local, supervisor, interrupt and fault.

*trace-on-return flag* (PFP.rt0 or bit 0 of the return-type field) stores the trace enable bit value when a system-supervisor call is made from user mode. When the call is made, the PC register trace enable bit is saved as the trace-on-return flag and then replaced by the trace controls bit in the system procedure table. On a return, the trace enable bit's original value is restored. This mechanism allows instruction tracing to be turned on or off when a supervisor mode switch occurs.

*prereturn-trace flag* (PFP.p) is used in conjunction with call-trace and prereturn-trace modes. If call-trace mode is enabled when a call is made, the processor sets the prereturn-trace flag; otherwise it clears the flag. Then, if this flag is set and prereturn-trace mode is enabled, a prereturn trace event is generated on a return, before any actions associated with the return operation are performed. See section 8.2, "TRACE MODES" (pg. 8-4) for a discussion of interaction between call-trace and prereturn-trace modes with the prereturn-trace flag.

**Table 5-3. Encoding of Return Status Field**

| Return Status Field | Call Type   | Return Action   |
|---------------------|---|---|
| p000                | Local call<br>(system-local call or system-supervisor call made from supervisor mode) | Local return<br>(return to local stack; no mode switch)   |
| p001                | Fault call  | Fault return  |
| p01t                | System-supervisor from user mode  | Supervisor return<br>(return to user stack, mode switch to user mode, trace enable bit is replaced with the t bit stored in the PFP register on the call) |
| p100                | reserved  |   |
| p101                | reserved  |   |
| p110                | reserved  |   |
| p111                | Interrupt call  | Interrupt return  |

**NOTE:** "p" is PFP.p (prereturn trace flag).  
 "t" denotes the trace-on-return flag; used only for system supervisor calls which cause a user-to-supervisor mode switch.



## 5.9 BRANCH-AND-LINK

A branch-and-link is executed using either the branch-and-link instruction (**bal**) or branch-and-link-extended instruction (**balx**). When either instruction executes, the processor branches to the first instruction of the called procedure (the target instruction), while saving a return IP for the calling procedure in a register. The called procedure uses the same set of local registers and stack frame as the calling procedure. For **bal**, the return IP is automatically saved in global register g14; for **balx**, the return IP instruction is saved in a register specified by one of the instruction's operands.

A return from a branch-and-link is generally carried out with a **bx** (branch extended) instruction, where the branch target is the address saved with the branch-and-link instruction. The branch-and-link method of making procedure calls is recommended for calls to leaf procedures. Leaf procedures typically call no other procedures. Branch-and-link is the fastest way to make a call, providing the calling procedure does not require its own registers or stack frame.



# INTERRUPTS



This chapter describes how a programmer uses the processor's interrupt mechanism, defines data structures used for interrupt handling and describes actions that the processor takes when handling an interrupt.

CHAPTER 12, INTERRUPT CONTROLLER describes the mechanism for signaling and posting interrupts; it is best suited for a system implementor.

## 6.1 OVERVIEW

**6**

An interrupt is an event that causes a temporary break in program execution so the processor can handle another chore. Interrupts commonly request I/O services or synchronize the processor with some external hardware activity. For interrupt handler portability across the i960® processor family implementations, the architecture defines a consistent interrupt state and interrupt-priority-handling mechanism. To manage and prioritize interrupt requests in parallel with processor execution, the i960 Cx processors provide an on-chip programmable interrupt controller.

Requests for interrupt service come from many sources. These requests are prioritized so that instruction execution is redirected only if an interrupt request is of higher priority than that of the executing task.

When the processor is redirected to service an interrupt, it uses a vector number that accompanies the interrupt request to locate the vector entry in the interrupt table. From that entry, it gets an address to the first instruction of the selected interrupt procedure. The processor then makes an implicit call to that procedure.

When the interrupt call is made, the processor uses a dedicated interrupt stack. A new frame is created for the interrupt on this stack and a new set of local registers is allocated to the interrupt procedure. The interrupted program's current state is also saved.

Upon return from the interrupt procedure, the processor restores the interrupted program's state, switches back to the stack that the processor was using prior to the interrupt and resumes program execution.

Since interrupts are handled based on priority, requested interrupts are often saved for later service rather than being handled immediately. The mechanism for saving the interrupt is referred to as interrupt posting. The mechanism the i960 Cx processors use for posting interrupts is described in section 12.2, "MANAGING INTERRUPT REQUESTS" (pg. 12-2).

On the i960 Cx processors, interrupt requests may originate from external hardware sources, internal DMA sources or from software. External interrupts are detected with the chip's 8-bit interrupt port and with a dedicated  $\overline{\text{NMI}}$  input. Interrupt requests originate from software by the **sysctl** instruction which signals interrupts. To manage and prioritize all possible interrupts, the microprocessor integrates an on-chip programmable interrupt controller. Integrated interrupt controller configuration and operation is described in CHAPTER 12, INTERRUPT CONTROLLER.

The i960 architecture defines two data structures to support interrupt processing (see Figure 6-1): the interrupt table and interrupt stack. The interrupt table contains 248 vectors for interrupt handling procedures and an area for posting software requested interrupts. The interrupt stack prevents interrupt handling procedures from overwriting the stack in use by the application program. It also allows the interrupt stack to be located in a different area of memory than the user and supervisor stack (e.g., fast SRAM).

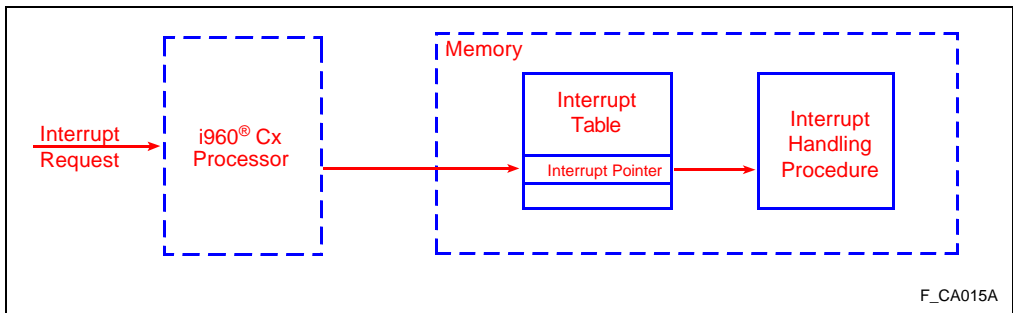


Figure 6-1. Interrupt Handling Data Structures

## 6.2 SOFTWARE REQUIREMENTS FOR INTERRUPT HANDLING

To use the processor's interrupt handling facilities, software must provide the following items in memory:

- Interrupt Table
- Interrupt Handler Routines
- Interrupt Stack

These items are generally established in memory as part of the initialization procedure. Once these items are present in memory and pointers to them have been entered in the appropriate system data structures, the processor handles interrupts automatically and independently from software.



### 6.3 INTERRUPT PRIORITY

Each interrupt procedure pointer is eight bits in length, which allows up to 256 unique procedure pointers to be defined. Each procedure pointer's priority is defined by dividing the procedure pointer number by eight. Thus, at each priority level, there are eight possible procedure pointers (e.g., procedure pointers 8 through 15 have a priority of 1 and procedure pointers 246 through 255 have a priority of 31). Procedure pointers 0 through 7 cannot be used. Since 0 priority is the lowest priority, a priority-0 interrupt will never successfully stop execution of a program of any priority.

The processor compares its current priority with the interrupt request priority to determine whether to service the interrupt immediately or to delay service. The interrupt is serviced immediately if the interrupt request priority is higher than the processor's current priority (the priority of the program or interrupt the processor is executing). If the interrupt priority is less than or equal to the processor's current priority, the processor does not service the request. When multiple interrupt requests are pending at the same priority level, the request with the highest vector number is serviced first.

Priority-31 interrupts are handled as a special case. Even when the processor is executing at priority level 31, a priority-31 interrupt will interrupt the processor. On the i960 Cx processor implementations, the non-maskable interrupt ( $\overline{\text{NMI}}$ ) interrupts priority-31 execution; no interrupt can interrupt an  $\overline{\text{NMI}}$  handler.

The processor may post requests for later servicing. Interrupts waiting to be serviced — called pending interrupts — are discussed in section 6.4.2, "Pending Interrupts" (pg. 6-5).

### 6.4 INTERRUPT TABLE

The interrupt table (Figure 6-2), 1028 bytes in length, can be located anywhere in the non-reserved address space. It must be aligned on a word boundary. The processor reads a pointer to interrupt table byte 0 during initialization. The interrupt table must be located in RAM since the processor must be able to read and write the table's pending interrupt section.

The interrupt table is divided into two sections: vector entries and pending interrupts. Each are described in the subsections that follow.

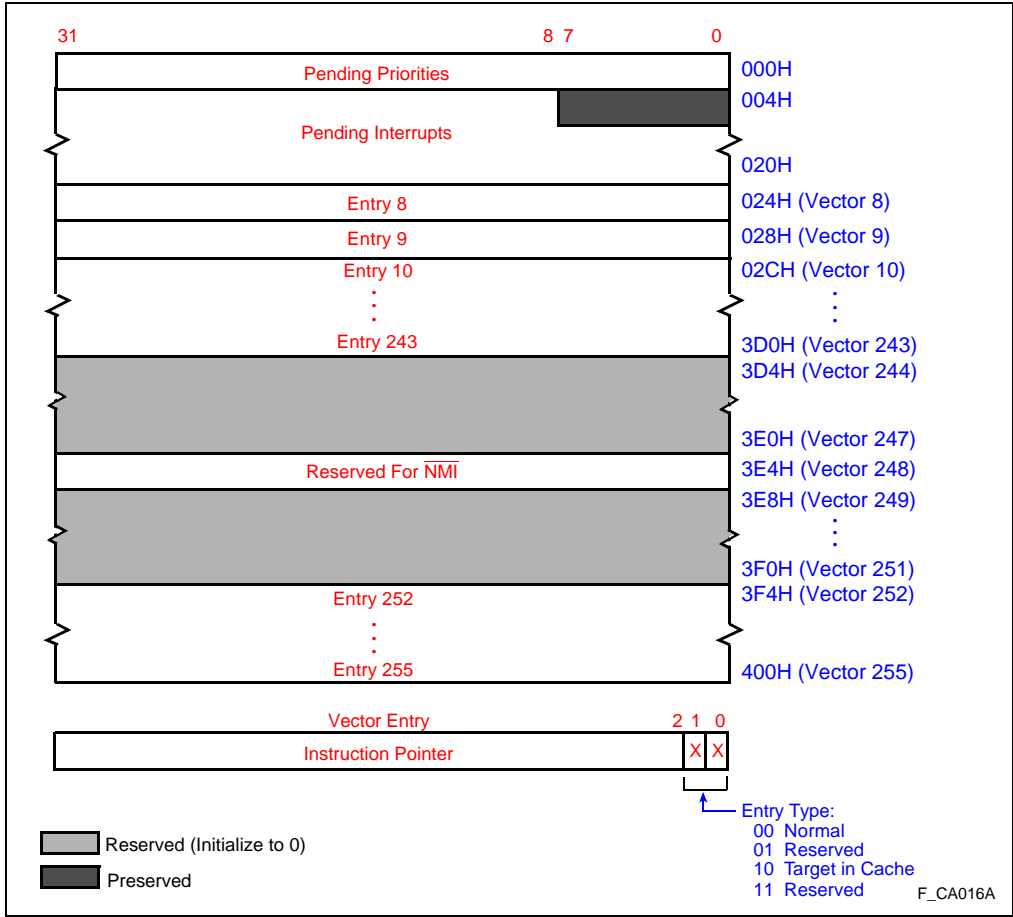


Figure 6-2. Interrupt Table

### 6.4.1 Vector Entries

A vector entry contains a specific interrupt handler’s address. When an interrupt is serviced, the processor branches to the address specified by the vector entry.

Each interrupt is associated with an 8-bit vector number which points to a vector entry in the interrupt table. The vector entry section contains 248 one-word entries. Vector numbers 8 through 243 and 252 through 255 and their associated vector entries are used for conventional interrupts. Vector number 244 through 247 and 249 through 251 are reserved. Vector number 248 and its associated vector entry is used for the non-maskable interrupt ( $\overline{\text{NMI}}$ ).



Vector entry 248 contains the  $\overline{\text{NMI}}$  handler address. When the processor is initialized, the  $\overline{\text{NMI}}$  vector located in the interrupt table is automatically read and stored in location 0H of internal data RAM. The NMI vector is subsequently fetched from internal data RAM to improve this interrupt's performance.

Vector entry structure is given at the bottom of Figure 6-2. Each interrupt procedure must begin on a word boundary, so the processor assumes that the vector's two least significant bits are 0. Bits 0 and 1 of an entry indicate entry type: type 000 indicates that the interrupt procedure should be fetched normally; type 010 indicates that the interrupt procedure should be fetched from the locked partition of the instruction cache. Refer to section 12.3.14, "Caching Interrupt-Handling Procedures" (pg. 12-21). The other possible entry types are reserved and must not be used.

#### 6.4.2 Pending Interrupts

6

The pending interrupts section comprises the interrupt table's first 36 bytes, divided into two fields: pending priorities (byte offset 0 through 3) and pending interrupts (4 through 35).

Each of the 32 bits in the pending priorities field indicate an interrupt priority. When the processor posts a pending interrupt in the interrupt table, the bit corresponding to the interrupt's priority is set. For example, if an interrupt with a priority of 10 is posted in the interrupt table, bit 10 is set.

Each of the pending interrupts field's 256 bits represent an interrupt procedure pointer. Byte offset 5 is for vectors 8 through 15, byte offset 6 is for vectors 16 through 23, and so on. Byte offset 4, the first byte of the pending interrupts field, is reserved. When an interrupt is posted, its corresponding bit in the pending interrupt field is set.

This encoding of the pending priority and pending interrupt fields permits the processor to first check if there are any pending interrupts with a priority greater than the current program and then determine the vector number of the interrupt with the highest priority.

#### 6.4.3 Caching Portions of the Interrupt Table

The architecture allows all or part of the interrupt table to be cached internally to the processor. The purpose of caching these fields is to reduce interrupt latency by allowing the processor access to certain interrupt procedure pointers and to the pending interrupt information without having to make memory accesses. The microprocessor caches the following:

- The value of the highest priority posted in the pending priorities field.
- A predefined subset of interrupt procedure pointers (entries from the interrupt table).
- Pending interrupts received from external interrupt pins and on-chip DMA controller (hardware requested interrupts).

## INTERRUPTS

This caching mechanism is non-transparent; in other words, the processor may modify fields in a cached interrupt table without modifying the same fields in the interrupt table itself. Vector caching is described in section 12.3.12, “Vector Caching Option” (pg. 12-20).

### 6.5 REQUESTING INTERRUPTS

On the i960 Cx microprocessors, interrupt requests may originate from external hardware sources, internal DMA sources or from software. External interrupts are detected with the chip’s 8-bit interrupt port and with a dedicated  $\overline{\text{NMI}}$  input. Interrupt requests originate from software by the **sysctl** instruction which signals interrupts. To manage and prioritize all possible interrupts, the microprocessor integrates an on-chip programmable interrupt controller. The configuration and operation of the integrated interrupt controller is described in section 12.2, “MANAGING INTERRUPT REQUESTS” (pg. 12-2).

Interrupts may be requested directly by a user’s program. This mechanism is often useful for requesting and prioritizing low-level tasks in a real time application.

Software can request interrupts in the following two ways: with the **sysctl** instruction or by posting an interrupt in the interrupt table’s pending-interrupts and pending-priorities fields.

#### 6.5.1 Posting Interrupts

For the i960 Cx processors, only software-requested interrupts are posted in the interrupt table; hardware-requested interrupts are posted in the interrupt pending (IPND) register. This register and the mechanism for requesting and posting hardware interrupts is described in section 12.3.6, “Interrupt Mask and Pending Registers (IMSK, IPND)” (pg. 12-14). Software posting of interrupts in the interrupt table can assist an application in prioritizing processing demands as follows:

- By posting interrupt requests in the interrupt table, the application can delay the servicing of low priority tasks which were signaled by a higher priority interrupt.
- In systems with more than one processor, both processors can post and service interrupts from a shared interrupt table. This interrupt table sharing allows processors to share the interrupt handling load or provide a communication mechanism between the processors.

To post a pending interrupt in the memory-resident interrupt table, the processor performs the atomic read/write operation that locks the interrupt table until the posting operation has completed (see Example 6-1).



**Example 6-1. Atomic Read/Write Operation**

```

# x and z are temporary registers
x ← atomic_read(pending_priorities);      # assert  $\overline{\text{LOCK}}$  pin
z ← read(pending_interrupts(vector_number/8));
x(vector_number/8) ← 1;
z(vector_number mod 8) ← 1;
write(pending_interrupts(vector_number/8)) ← z;
atomic_write(pending_priorities) ← x;     # deassert  $\overline{\text{LOCK}}$ 

```

The  $\overline{\text{LOCK}}$  pin can be used to prevent other agents on the bus from accessing the interrupt table during the posting operation. On the i960 Cx microprocessor, posting software interrupts is performed by **sysctl**.

6

**6.5.2 Posting Interrupts Directly to the Interrupt Table**

The i960 Cx processors — or external agent that is sharing memory with the microprocessor (such as an I/O processor or another i960 Cx processor) — can post pending interrupts directly in the interrupt table by setting the appropriate bits in the pending priorities and pending interrupts fields. This action, however, does not ensure that the core will handle the interrupt immediately, nor does it cause the core to update the value in the software priority register. To do this, the **sysctl** instruction should be used as described in the preceding sections.

**sysctl** can be used at any time to explicitly force the core to check the interrupt table for pending interrupts. This is done by specifying an invalid vector number in the range of 0 to 7. For example, when an external agent is posting interrupts to a shared interrupt table, **sysctl** could be executed periodically to guarantee recognition of pending interrupts which were posted in the table by the external agent.

An external I/O agent or a coprocessor posts interrupts to a processor's interrupt table in memory in the same manner described above, providing it has the capability to perform atomic operations on memory. When interrupts are posted in this manner, pending interrupts and pending priorities must be modified in specific order and not allow access by the processor or other external agents during the atomic modify operations.

The processor automatically checks the memory-based interrupt table when the processor posts an interrupt using **sysctl** with a post interrupt message type.

When the processor finds a pending interrupt, it handles it as if it had just received the interrupt. If the processor finds two pending interrupts at the same priority, it services the interrupt with the highest vector number first.

**Example 6-2. Modifying Pending Interrupts**

```
#set pending interrupt bit
atomic_modify(pending_interrupts(vector_number/8));
#set pending priority bit
atomic_modify(pending_priorities);
```

**6.6 SYSTEM CONTROL INSTRUCTION (sysctl)**

**sysctl** is typically used to request an interrupt in a program (see Example 6-3). The request interrupt message type (00H) is selected and the interrupt procedure pointer number is specified in the least significant byte of the instruction operand. See section 4.3, “SYSTEM CONTROL FUNCTIONS” (pg. 4-19) for a complete discussion of **sysctl**.

**Example 6-3. Using sysctl to Request an Interrupt**

```
ldconst      0x53,g5      # Vector number 53H is loaded
                                     # into byte 0 of register g5 and
                                     # the value is zero extended into
                                     # byte 1 of the register
sysctl       g5, g5, g5   # Vector number 53H is posted
```

A literal can be used to post an interrupt with a vector number from 8 to 31. Here, the required value of 00H in the second byte of a register operand is implied.

The action of the core when it executes the **sysctl** instruction is as follows:

1. The core performs an atomic write to the interrupt table and sets bits in the pending-interrupts and pending-priorities fields that correspond to the requested interrupt.
2. The core updates the internal software priority register with the value of the highest pending priority from the interrupt table. This may be the priority of the interrupt that was just posted.

The interrupt controller continuously compares the following three values: software priority register, current process priority, priority of the highest pending hardware-generated interrupt. When the software priority register value is the highest of the three, the following actions occur:

1. The interrupt controller signals the core that a software-generated interrupt is to be serviced.



2. The core checks the interrupt table in memory, determines the vector number of the highest priority pending interrupt and clears the pending-interrupts and pending-priorities bits in the table that correspond to that interrupt.
3. The core detects the interrupt with the next highest priority which is posted in the interrupt table (if any) and writes that value into the software priority register.
4. The core services the highest priority interrupt.

If more than one pending interrupt is posted in the interrupt table at the same interrupt priority, the core handles the interrupt with the highest vector number first. The software priority register is an internal register and, as such, is not visible to the user. The core only updates this register's value when **sysctl** requests an interrupt or when a software-generated interrupt is serviced.

6

## 6.7 INTERRUPT STACK AND INTERRUPT RECORD

The interrupt stack can be located anywhere in the non-reserved address space. The processor obtains a pointer to the base of the stack during initialization. The interrupt stack has the same structure as the local procedure stack described in section 5.2.1, “Local Registers and the Procedure Stack” (pg. 5-2). As with the local stack, the interrupt stack grows from lower addresses to higher addresses.

The processor saves the state of an interrupted program — or an interrupted interrupt procedure — in a record on the interrupt stack. Figure 6-3 shows the structure of this interrupt record.

The interrupt record is always stored on the interrupt stack adjacent to the new frame that is created for the interrupt handling procedure. It includes the state of the AC and PC registers at the time the interrupt was received and the interrupt procedure pointer number used. Referenced to the new frame pointer address (designated NFP), the saved AC register is located at address NFP-12; the saved PC register is located at address NFP-16.

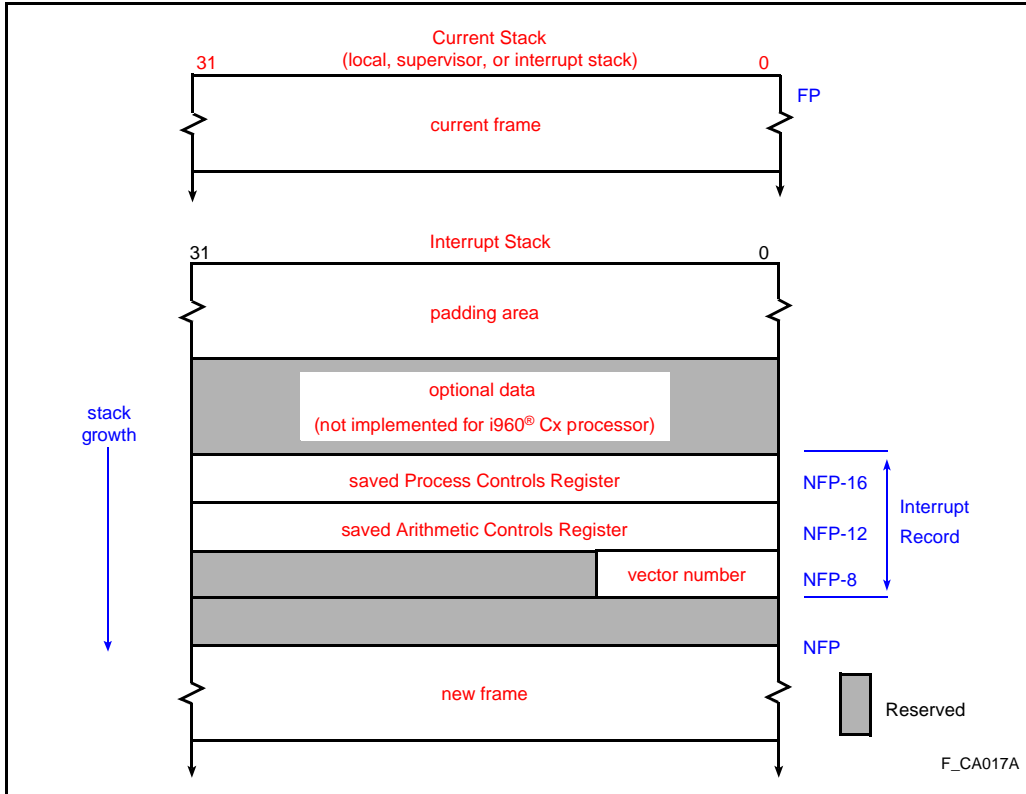


Figure 6-3. Storage of an Interrupt Record on the Interrupt Stack

### 6.8 INTERRUPT SERVICE ROUTINES

An interrupt handling procedure performs a specific action that is associated with a particular interrupt procedure pointer. For example, one interrupt handler task might be to initiate a DMA transfer. The interrupt handler procedures can be located anywhere in the non-reserved address space. Since instructions in the i960 processor family architecture must be word aligned, each procedure must begin on a word boundary.

When an interrupt handling procedure is called, the processor allocates a new frame on the interrupt stack and a set of local registers for the procedure. If not already in supervisor mode, the processor always switches to supervisor mode while an interrupt is being handled. It also saves the states of the AC and PC registers for the interrupted program. The interrupt procedure shares the



remainder of the execution environment resources (namely the global registers, special function registers and the address space) with the interrupted program. Thus, interrupt procedures must preserve and restore the state of any resources shared with a non-cooperating program.

### CAUTION!

Interrupt procedures must preserve and restore the state of any resources shared with a non-cooperating program. For example, an interrupt procedure which uses a global register which is not permanently allocated to it should save the register's contents before it uses the register and restore the contents before returning from the interrupt handler.

To reduce interrupt latency to critical interrupt routines, interrupt handlers may be locked into the instruction cache. See section 12.3.14, "Caching Interrupt-Handling Procedures" (pg. 12-21) for a complete description.

**6**

## 6.9 INTERRUPT CONTEXT SWITCH

When the processor services an interrupt, it automatically saves the interrupted program state or interrupt procedure and calls the interrupt handling procedure associated with the new interrupt request. When the interrupt handler completes, the processor automatically restores the interrupted program state.

The method that the processor uses to service an interrupt depends on the processor state when the interrupt is received. If the processor is executing a background task when an interrupt request is to be serviced, the interrupt context switch must change stacks to the interrupt stack. This is called an executing-state interrupt. If the processor is already executing an interrupt handler, no stack switch is required since the interrupt stack will already be in use. This is called an interrupted-state interrupt.

The following subsections describe interrupt handling actions for executing-state and interrupted-state interrupts. In both cases, it is assumed that the interrupt priority is higher than that of the processor and thus is serviced immediately when the processor receives it.

## INTERRUPTS

### 6.9.1 Executing-State Interrupt

When the processor receives an interrupt while in the executing state (i.e., executing a program), it performs the following actions to service the interrupt. This procedure is the same regardless of whether the processor is in user or supervisor mode when the interrupt occurs. The processor:

1. switches to the interrupt stack (as shown in Figure 6-3). The interrupt stack pointer becomes the new stack pointer for the processor.
2. saves the current state of process controls and arithmetic controls in an interrupt record on the interrupt stack. The processor also saves the interrupt procedure pointer number.
3. allocates a new frame on the interrupt stack and loads the new frame pointer (NFP) in global register g15.
4. switches to the interrupted state.
5. sets the state flag in its internal process controls to interrupted, its execution mode to supervisor and its priority to the priority of the interrupt. Setting the processor's priority to that of the interrupt ensures that lower priority interrupts cannot interrupt the servicing of the current interrupt.
6. clears the trace-fault-pending and trace-enable flags in its internal process controls. Clearing these flags allows the interrupt to be handled without trace faults being raised.
7. sets the frame return status field (associated with the PFP in register r0) to  $111_2$ .
8. performs a call operation as described in CHAPTER 5, PROCEDURE CALLS. The address for the called procedure is specified in the interrupt table for the specified interrupt procedure pointer.

Once the processor completes the interrupt procedure, it performs the following return actions:

1. copies the arithmetic controls field and the process controls field from the interrupt record into the arithmetic controls register and process controls, respectively. It also returns the trace-fault-pending flags and trace-enable bit to their values before the interrupt occurred.
2. deallocates the current stack frame and interrupt record from the interrupt stack and switches to the local stack or the supervisor stack (the one it was using when it was interrupted).
3. performs a return operation as described in CHAPTER 5, PROCEDURE CALLS. This causes the processor to switch back to the local or supervisor stack (whichever it was using before the interrupt).
4. switches to the executing state and resumes work on the program, if there are no pending interrupts to be serviced or trace faults to be handled.





### 6.9.2 Interrupted-State Interrupt

If the processor receives an interrupt while it is servicing another interrupt, and the new interrupt has a higher priority than the interrupt currently being serviced, the current interrupt-handler routine is interrupted. Here, the processor performs the same interrupt-servicing action as is described in section 6.9.1, “Executing-State Interrupt” (pg. 6-12) to save the state of the interrupted interrupt-handler routine. The interrupt record is saved on the top of the interrupt stack prior to the new frame that is created for use in servicing the new interrupt.

On the return from the current interrupt handler to the previous interrupt handler, the processor deallocates the current stack frame and interrupt record, and stays on the interrupt stack.

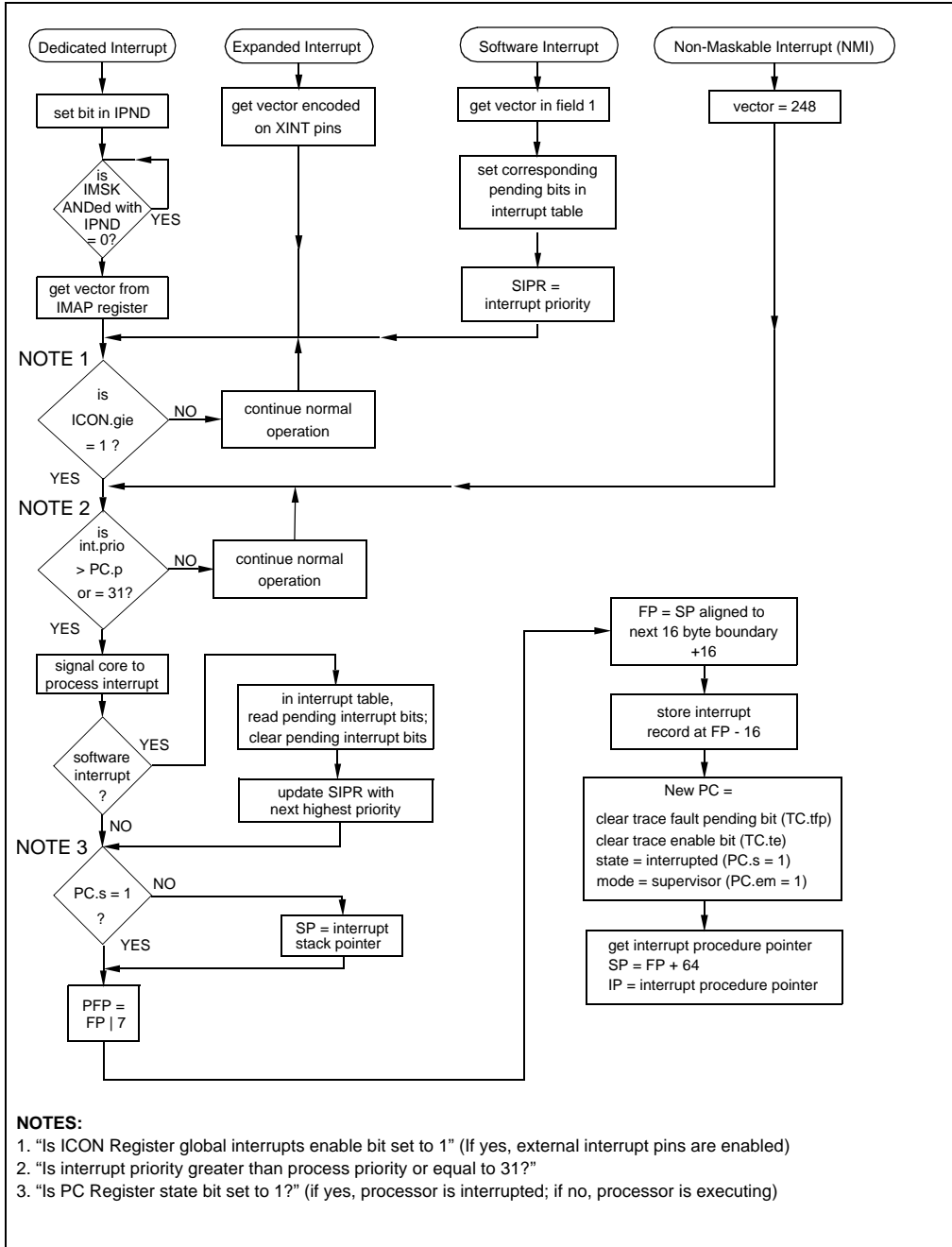


Figure 6-4. Flowchart for Worst Case Interrupt Latency

FAULTS



This chapter describes the i960® Cx processors' fault handling facilities. Subjects covered include the fault handling data structures and fault handling mechanism. See section 7.10, "FAULT REFERENCE" (pg. 7-20) for detailed information on each fault type.

7.1 FAULT HANDLING FACILITIES OVERVIEW

The i960 processor architecture defines various conditions in code and/or the processor's internal state that could cause the processor to deliver incorrect or inappropriate results or that could cause it to head down an undesirable control path. These are called *fault conditions*. For example: for inappropriate operand values and for invalid opcodes and addressing modes, the architecture defines faults for divide-by-zero and overflow conditions on integer calculations.



As shown in Figure 7-1, the architecture defines a fault table, a system procedure table, a set of fault handling procedures and a stack (user stack, supervisor stack or both) to handle processor-generated faults.

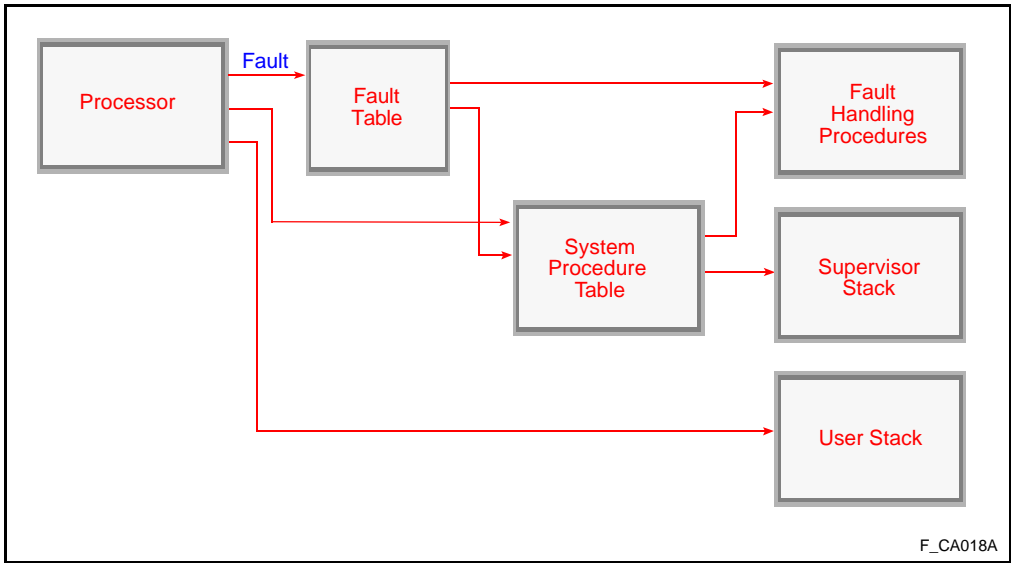


Figure 7-1. Fault-Handling Data Structures



## FAULTS

The fault table contains pointers to fault handling procedures. The system procedure table optionally provides an interface to any fault handling procedure and allows faults to be handled in supervisor mode. Stack frames for fault handling procedures are created on either the user or supervisor stack, depending on the mode in which the fault is handled.

Once these data structures and the code for the fault procedures are established in memory, the processor handles faults automatically and independently from application software.

The processor can detect a fault at any time while executing instructions: whether from a program, interrupt handling procedure or fault handling procedure. If a fault occurs during program execution, the processor determines the fault type and selects a corresponding fault handling procedure from the fault table. It then invokes the fault handling procedure by means of an implicit call. As described later in this chapter, the fault handler call can be:

- a local call (call-extended operation)
- a system-local call (local call through the system procedure table)
- a system-supervisor call (also through the system procedure table)

As part of the implicit call to the fault handling procedure, the processor creates a fault record on the stack that the fault handling procedure is using. This record includes information on the fault and the processor's state when the fault was generated.

After the fault record is created, the processor executes the selected fault handling procedure. If the fault handling procedure recovers from the fault, the processor then restores itself to its state prior to the fault and resumes program execution with no break in program control flow. If the fault handling procedure cannot recover from the fault, the fault handler can call a debug monitor or perform an action such as resetting the processor.

This procedure call mechanism handles faults that occur:

- while the processor is servicing an interrupt
- while the processor is working on another fault handling procedure

## 7.2 FAULT TYPES

The i960 architecture defines a basic set of faults which are categorized by type and subtype. Each fault has a unique type and subtype number. When the processor detects a fault, it records the fault type and subtype numbers in a fault record. It then uses the type number to select a fault handling procedure.



The fault handling procedure can optionally use the subtype number to select a specific fault handling action. The i960 Cx processor recognizes i960 architecture-defined faults and a new fault subtype for detecting unaligned memory accesses. Table 7-1 lists all faults that the i960 Cx processor detects, arranged by type and subtype. Text that follows the table gives column definitions.

**Table 7-1. i960<sup>®</sup> Cx Processor Fault Types and Subtypes**

| Fault Type |                           | Fault Subtype          |                        | Fault Record |
|------------|---------------------------|------------------------|------------------------|--------------|
| Number     | Name                      | Number or Bit Position | Name                   |              |
| 1H         | Trace                     | Bit 1                  | Instruction Trace      | XX01 XX02H   |
|            |                           | Bit 2                  | Branch Trace           | XX01 XX04H   |
|            |                           | Bit 3                  | Call Trace             | XX01 XX08H   |
|            |                           | Bit 4                  | Return Trace           | XX01 XX10H   |
|            |                           | Bit 5                  | Prereturn Trace        | XX01 XX20H   |
|            |                           | Bit 6                  | Supervisor Trace       | XX01 XX40H   |
|            |                           | Bit 7                  | Breakpoint Trace       | XX01 XX80H   |
| 2H         | Operation                 | 1H                     | Invalid Opcode         | XX02 XX01H   |
|            |                           | 2H                     | Unimplemented          | XX02 XX02H   |
|            |                           | 3H                     | Unaligned <sup>1</sup> | XX02 XX03H   |
|            |                           | 4H                     | Invalid Operand        | XX02 XX04H   |
| 3H         | Arithmetic                | 1H                     | Integer Overflow       | XX03 XX01H   |
|            |                           | 2H                     | Arithmetic Zero-Divide | XX03 XX02H   |
| 4H         | Reserved (Floating Point) |                        |                        |              |
| 5H         | Constraint                | 1H                     | Constraint Range       | XX05 XX01H   |
|            |                           | 2H                     | Privileged             | XX05 XX02H   |
| 6H         | Reserved                  |                        |                        |              |
| 7H         | Protection                | Bit 1                  | Length                 | XX07 XX01H   |
| 8H         | Reserved                  |                        |                        |              |
| 9H         | Reserved                  |                        |                        |              |
| AH         | Type                      | 1H                     | Type Mismatch          | XX0A XX01H   |
| BH - FH    | Reserved                  |                        |                        |              |

7

**NOTE:**

1. The operation-unaligned fault is an i960 Cx processor-specific extension.



## FAULTS

In Table 7-1:

- The first (left-most) column contains the fault type numbers in hexadecimal.
- The second column shows the fault type name.
- The third column gives the fault subtype number as either: (1) a hexadecimal number or (2) as a bit position in the fault record's 8-bit fault subtype field. The bit position method of indicating a fault subtype is used for certain faults — such as trace faults — in which two or more fault subtypes may occur simultaneously.
- The fourth column gives the fault subtype name. For convenience, individual faults are referred to in this manual by their fault-subtype name. Thus an operation-invalid-operand fault is referred to as simply an invalid-operand fault; an arithmetic-integer-overflow fault is referred to as an integer-overflow fault.
- The fifth column shows the encoding of the word in the fault record that contains the fault type and fault subtype numbers.

Other i960 processor family members may provide extensions that recognize additional fault conditions. Fault type and subtype encoding allows all faults to be included in the fault table: those which are common to all i960 processors and those which are specific to one or more family members. The fault types are used consistently for all family members. For example, Fault Type 4 is reserved for floating point faults. Any i960 processor with floating point operations uses Entry 4 to store the pointer to the floating point fault handling procedure.

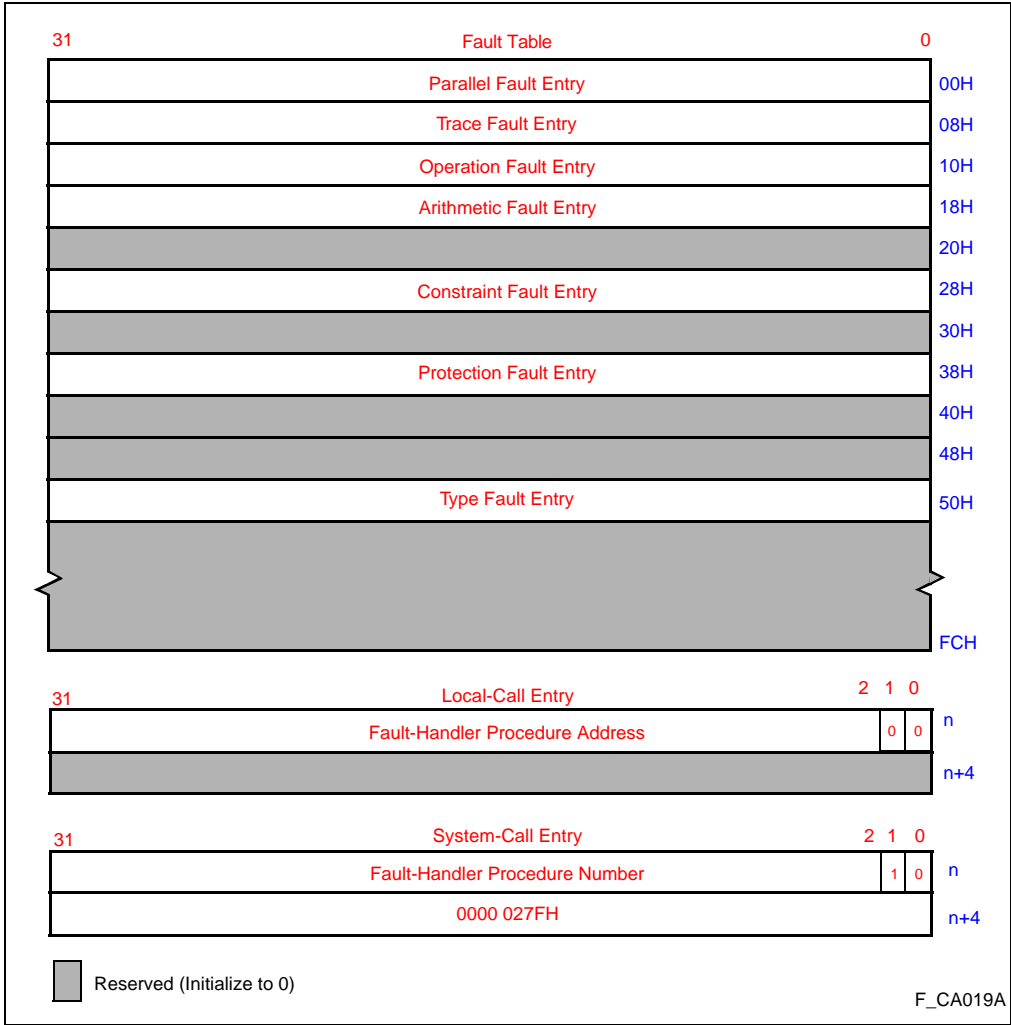
### 7.3 FAULT TABLE

The fault table (Figure 7-2) is the processor's pathway to the fault handling procedures. It can be located anywhere in the address space. The processor obtains a pointer to the fault table during initialization.

The fault table contains one entry for each fault type. When a fault occurs, the processor uses the fault type to select an entry in the fault table. From this entry, the processor obtains a pointer to the fault handling procedure for the type of fault that occurred. Once called, a fault handling procedure has the option of reading the fault subtype or subtypes from the fault record when determining the appropriate fault recovery action.







7

Figure 7-2. Fault Table and Fault Table Entries

## FAULTS

As indicated in Figure 7-2, two fault table entry types are allowed: local-call entry and system-call entry. Each is two words in length. The entry type field (bits 0 and 1 of the entry's first word) and the value in the entry's second word determine the entry type.

|  |   |
|--|---|
| <i>local-call entry</i><br>(type 000)  | Provides an instruction pointer for the fault handling procedure. The processor uses this entry to invoke the specified procedure by means of an implicit local-call operation. The second word of a local procedure entry is reserved; it must be set to zero when the fault table is created and not accessed after that.   |
| <i>system-call entry</i><br>(type 010) | Provides a procedure number in the system procedure table. This entry must have an entry type of 010 and a value in the second word of 0000 027FH. Using this entry, the processor invokes the specified fault handling procedure by means of an implicit call-system operation similar to that performed for the <b>calls</b> instruction. A fault handling procedure in the system procedure table can be called with a system-local call or a system-supervisor call, depending on the entry type in the system-procedure table. |

To summarize, a fault handling procedure can be invoked through the fault table in any of three ways: a local call, a system-local call or a system-supervisor call.

### 7.4 STACK USED IN FAULT HANDLING

The architecture does not define a dedicated fault handling stack. Instead, to handle a fault, the processor uses either the user, interrupt or supervisor stack — whichever is active when the fault is generated — with one exception: if the user stack is active when a fault is generated and the fault handling procedure is called with an implicit supervisor call, the processor switches to the supervisor stack to handle the fault.

### 7.5 FAULT RECORD

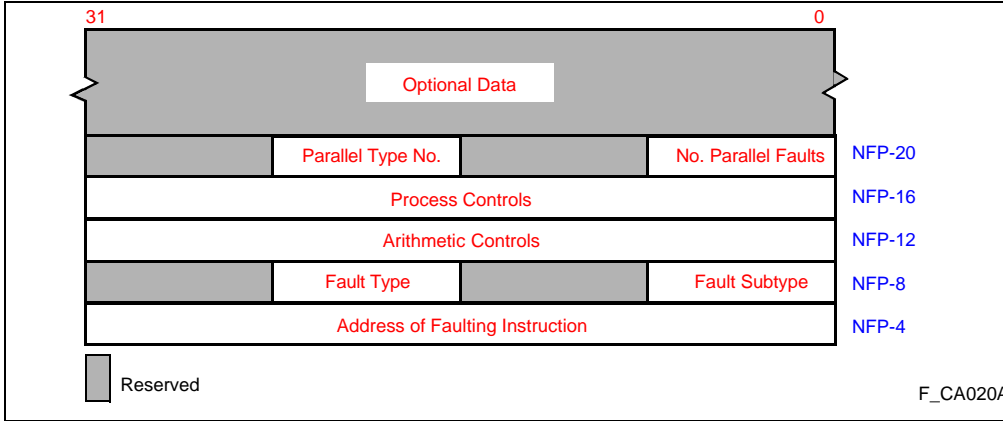
When a fault occurs, the processor records information about the fault in a fault record in memory. The fault handling procedure uses the information in the fault record to correct or recover from the fault condition and, if possible, resume program execution. The fault record is stored on the stack that the fault handling procedure will use to handle the fault.

#### 7.5.1 Fault Record Data

Figure 7-3 shows the fault record's structure. In this record, the fault's type number is stored in the fault type field and the fault's subtype number (or bit positions for multiple subtypes) is stored in the fault subtype field. The address-of-faulting-instruction field contains the IP of the instruction which caused the processor to fault.



When a fault is generated, the existing PC and AC register contents are stored in their respective fault record fields. The processor uses this information to resume program execution after the fault is handled. In the case of parallel instruction execution, these fields contain register states that were pending when the processor completed execution of all parallel and out-of-order instructions.



**Figure 7-3. Fault Record**

Optional data fields are defined for certain faults. These fields contain additional information about the faulting conditions, usually to assist resumption. The i960 Cx processor uses these optional data fields for two fault types only: parallel faults and operation-unaligned faults. The processor can generate parallel faults when instructions are executed in parallel. section 7.6.1, “Multiple Faults” (pg. 7-9), describes optional data field usage for parallel faults; section 7.10.3, “Operation Faults” (pg. 7-23), describes optional data field usage for operation-unaligned faults. All unused bytes in the fault record are reserved.

**7.5.2 Return Instruction Pointer (RIP)**

When a fault handling procedure is called, a return instruction pointer (RIP) is saved in the RIP register (r2). The RIP points to an instruction where program execution can be resumed with no break in the program’s control flow. It generally points to the faulting instruction or to the next instruction to be executed. In some instances, however, the RIP is undefined. section 7.10, “FAULT REFERENCE” (pg. 7-20), defines the RIP content for each fault.



### 7.5.3 Fault Record Location

The fault record is stored in the stack that the processor uses to execute the fault handling procedure. As shown in Figure 7-4, this stack can be the user stack, supervisor stack or interrupt stack. The fault record begins at byte address NFP-1. NFP refers to the new frame pointer which is computed by adding the memory size allocated for padding and the fault record to the new stack pointer (NSP).

The processor automatically determines the number of bytes required for the fault record and increments the FP by that amount, rounding it off to the next highest 16-byte boundary. Fault record size is variable, based on the size of the optional fault-data portion of the fault record.

Stack frame alignment is defined for each implementation of the i960 architecture. This alignment boundary is calculated from the relationship  $SALIGN * 16$ . For example, if SALIGN is selected to be 4, stack frames are aligned on 64-byte boundaries. In the i960 Cx processors,  $SALIGN=1$ .

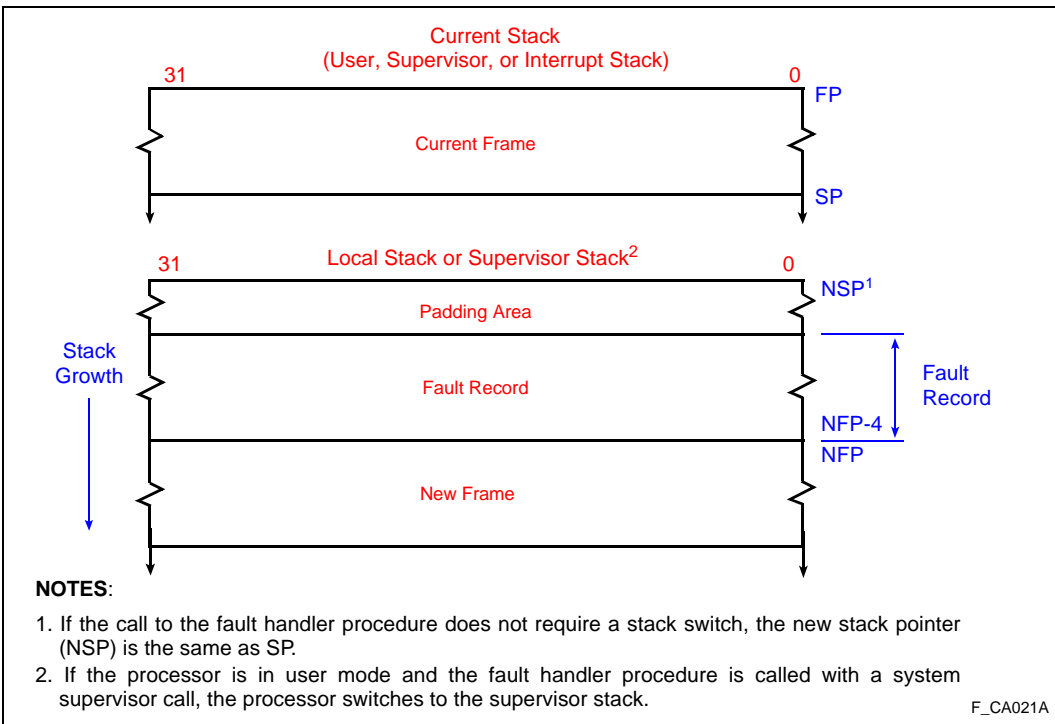


Figure 7-4. Storage of the Fault Record on the Stack



## 7.6 MULTIPLE AND PARALLEL FAULTS

Multiple fault conditions can occur during a single instruction execution and during multiple instruction execution when the instructions are executed by parallel execution units within the processor. The following sections describe how faults are handled under these conditions.

### 7.6.1 Multiple Faults

Multiple fault conditions can occur during a single instruction execution. For example, an instruction can have an invalid operand and unaligned address. When this situation occurs, the processor is required to recognize and generate at least one of the fault conditions. The processor may not detect all fault conditions and may not report all detected faults.

In a multiple fault situation, the reported fault condition is left to the implementation. The architecture, however, does define the criteria for determining which fault to report when trace fault conditions are one or more of the fault conditions.

### 7.6.2 Multiple Trace Fault Conditions Only

7

Multiple trace fault conditions that single instruction executions generate are reported in a single trace fault. To support this multiple fault reporting, the trace fault uses bit positions in the fault-subtype field to indicate occurrences of multiple faults of the same type (Table 7-1).

For example, when instruction tracing is enabled, an instruction trace fault condition is detected on each instruction that is executed, along with other trace fault conditions that are enabled (e.g., a call trace fault or a branch trace fault.) The processor generates a trace fault after each instruction and sets the appropriate bit or bits in the fault-subtype field to indicate the instruction trace fault and any other trace fault subtypes that occurred.

### 7.6.3 Multiple Trace Fault Conditions with Other Fault Conditions

The execution of a single instruction can create one or more trace fault conditions in addition to multiple non-trace fault conditions. When this occurs, the processor generates at least two faults: a non-trace fault and a trace fault.

The non-trace fault is handled first and the trace fault is triggered immediately after executing the return instruction (**ret**) at the end of the non-trace fault handler.

### 7.6.4 Parallel Faults

The i960 Cx processors exploit the architecture's tolerance of parallel and out-of-order instruction execution by issuing instructions to multiple, independent execution units on the chip. The following sub-sections describe how the processor handles faults in this environment.

## FAULTS

### 7.6.5 Faults in One Parallel Instruction

When a fault occurs during the execution of a particular instruction, it is not possible to suspend other instructions that are already executing in other execution units. To handle the fault, the processor continues executing instructions until each execution unit instruction and all out-of-order instructions are executed. For example, if an integer overflow occurs during the addition in the following code example, the fault is detected before the multiply has completed execution. Before invoking the integer-overflow fault handling procedure, the processor waits for the multiply to complete.

```
multi  g2, g4, g6;
addi   g8, g9, g10;      # results in integer overflow
```

### 7.6.6 Faults in Multiple Parallel Instructions

When executing instructions in parallel, it is possible for faults to occur in more than one currently executing instruction. In the code sequence above, for example, an integer overflow fault could occur for both the **multi** and **addi** instructions, with the fault from the **addi** instruction being recognized by the processor first. To report multiple parallel faults, the architecture provides the parallel fault type.

In these parallel fault situations, the processor saves the fault type and subtype of the second and subsequent faults detected in the optional data field of the fault record. The fault handling procedure for parallel faults can then analyze the fault record and handle the faults. The fault record for parallel faults is described in the next section.

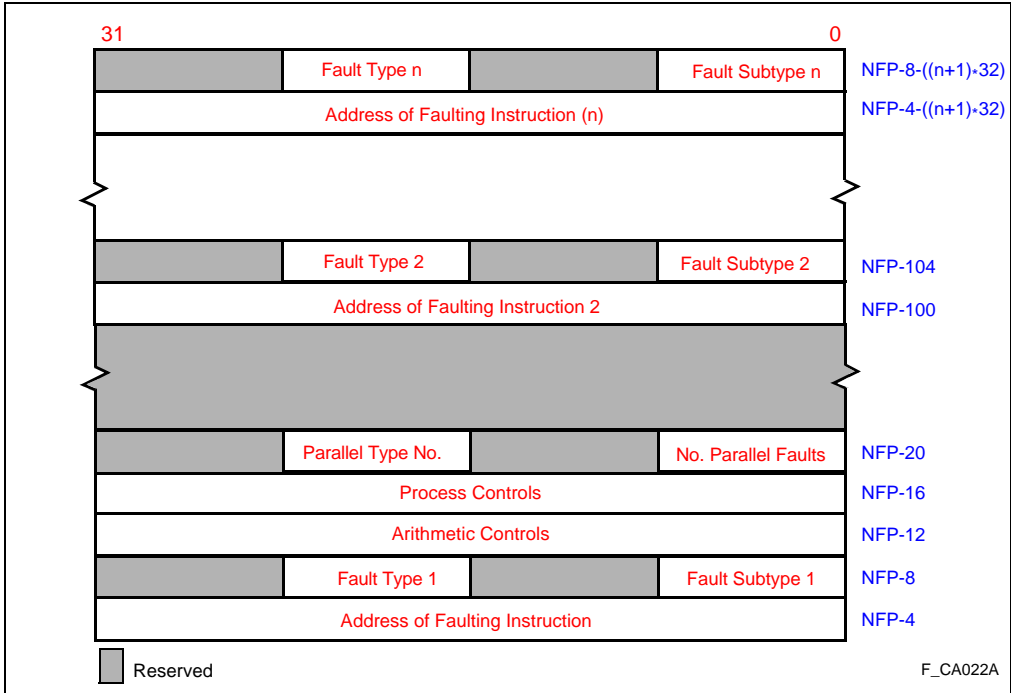
The existence of multiple parallel faults is often catastrophic. Multiple parallel faults are generated as imprecise faults, which means that recovery from the faults is normally not possible. Imprecise faults are described in section 7.9, “PRECISE AND IMPRECISE FAULTS” (pg. 7-17). Unless imprecise faults are disallowed, a parallel-fault-handling procedure generally does not attempt to recover from the faults, but instead calls a debug monitor to analyze the faults. If recovery from every parallel fault is possible, the RIP allows the processor to resume executing the program when the fault handling has completed.

Even though multiple faults can be generated by multiple instructions executing in parallel, only one fault is ordinarily generated per instruction, as described in section 7.6.1, “Multiple Faults” (pg. 7-9).

### 7.6.7 Fault Record for Parallel Faults

Figure 7-5 shows the structure of the fault record for parallel faults.





7

**Figure 7-5. Fault Record for Parallel Faults**

To calculate byte offsets, “n” indicates fault number. Thus, for the second fault recorded (n=2), the relationship  $(NFP - 4 - ((n+1) * 32))$  reduces to NFP-100. For the i960 Cx processors, number of parallel faults allowed is 2 or 3.

When multiple parallel faults occur, the processor selects one of the faults and records it in the first 16 bytes of the fault record as described in section 7.5.1, “Fault Record Data” (pg. 7-6) for the remaining parallel faults is then written to the fault record’s optional data field and the fault handling procedure for parallel faults is invoked.

The first word in the fault record’s optional data field (NFP-20) contains information about the parallel faults. The byte at offset NFP-18 contains 00H (encoding for the parallel fault type); the byte at NFP-20 contains the number of parallel faults. The optional data field also contains a 32-byte parallel fault record for each additional fault. These parallel fault records are stored incrementally in the fault record starting at byte offset NFP-97. The fault record for each additional fault contains only the fault type, fault subtype and address-of-faulting-instruction field. (AC and PC register values are not given for these faults; these are given in the fault record for the first fault.)



## FAULTS

### 7.7 FAULT HANDLING PROCEDURES

The fault handling procedures can be located anywhere in the address space. Each procedure must begin on a word boundary. The processor can execute the procedure in user mode or supervisor mode, depending on the type of fault table entry.

To resume work on a program at the point where a fault occurred (following the recovery action of the fault handling procedure), the fault handling procedure must be executed in supervisor mode. The reason for this requirement is described in section 7.7.3, “Returning to the Point in the Program Where the Fault Occurred” (pg. 7-13).

#### 7.7.1 Possible Fault Handling Procedure Actions

The processor allows easy recovery from many faults that occur. When fault recovery is possible, the processor’s fault handling mechanism allows the processor to automatically resume work on the program or interrupt pending when the fault occurred. Resumption is initiated with a **ret** instruction in the fault handling procedure.

If recovery from the fault is not possible or not desirable, the fault handling procedure can take one of the following actions, depending on the nature and severity of the fault condition (or conditions, in the case of multiple faults):

- Return to a point in the program or interrupt code other than the point of the fault.
- Call a debug monitor.
- Explicitly write the processor state and fault record into memory and perform processor or system shutdown.
- Perform processor or system shutdown without explicitly saving the processor state or fault information.

When working with the processor at the development level, a common fault handling procedure action is to save the fault and processor state information and make a call to a debugging device such as a debugging monitor. This device can then be used to analyze the fault information.

#### 7.7.2 Program Resumption Following a Fault

Because of the i960 Cx processors’ multi-stage execution pipeline, faults can occur:

- before execution of the faulting instruction (i.e., the instruction that causes the fault)
- during instruction execution
- immediately following execution

When the fault occurs before the faulting instruction is executed, the faulting instruction may be re-executed upon return from the fault handling procedure.





When a fault occurs during or after execution of the faulting instruction, the fault may be accompanied by a program state change such that program execution cannot be resumed after the fault is handled. For example, when an integer overflow fault occurs, the overflow value is stored in the destination. If the destination register is the same as one of the source registers, the source value is lost, making it impossible to re-execute the faulting instruction.

In general, resumption of program execution with no changes in the program's control flow is possible with the following fault types or subtypes:

- All Operation Subtypes
- All Constraint Subtypes
- Length
- Arithmetic Zero Divide
- All Trace Subtypes

Resumption of the program may or may not be possible with the following fault subtype:

- Integer Overflow

The effect of specific fault types on a program is defined in section 7.10, "FAULT REFERENCE" (pg. 7-20) under the heading *Program State Changes*.

7

### 7.7.3 Returning to the Point in the Program Where the Fault Occurred

As described in section 7.7.2, "Program Resumption Following a Fault" (pg. 7-12), most faults can be handled such that program control flow is not affected. In this case, the processor allows work on a program to be resumed at the point where the fault occurred, following a return from a fault handling procedure (initiated with a **ret** instruction). The resumption mechanism used here is similar to that provided for returning from an interrupt handler.

To use this mechanism, the fault handling procedure must be invoked using a supervisor call. This method is required because — to resume work on the program at the point where the fault occurred — the saved process controls in the fault record must be copied back into the PC register upon return from the fault handling procedure. The processor only performs this action if the processor is in supervisor mode when the return is executed.

### 7.7.4 Returning to a Point in the Program Other Than Where the Fault Occurred

A fault handling procedure can also return to a point in the program other than where the fault occurred. To do this, the fault procedure must alter the RIP.

## FAULTS

To predictably perform a return from a fault handling procedure to an alternate point in the program, the fault handling procedure should perform the following four steps:

1. Flush the local register sets to the stack with a **flushreg** instruction,
2. Modify the RIP in the previous frame,
3. Clear the trace-fault-pending flag in the fault record's process controls field before the return,
4. Execute a return with the **ret** instruction.

Use this technique carefully and only in situations where the fault handling procedure is closely coupled with the application program. Also, a return of this type can only be performed if the processor is in supervisor mode prior to the return.

### 7.7.5 Fault Controls

Certain fault types and subtypes employ mask bits or flags that determine whether or not a fault is generated when a fault condition occurs. Table 7-2 summarizes these flags and masks, data structures in which they are located, fault subtypes they affect and where more information about each can be found.

The integer overflow mask bit inhibits the generation of integer overflow faults. The use of this mask is discussed in section 7.10, "FAULT REFERENCE" (pg. 7-20).

The no-imprecise-faults (NIF) bit controls the synchronizing of faults for a category of faults called imprecise faults. The function of this bit is described in section 7.9, "PRECISE AND IMPRECISE FAULTS" (pg. 7-17).

TC register trace mode bits and PC register trace enable bit support trace faults. Trace mode bits enable trace modes; the trace enable bit enables trace fault generation. The use of these bits is described in the trace faults description in section 7.10, "FAULT REFERENCE" (pg. 7-20). Further discussion of these flags is provided in CHAPTER 8, TRACING AND DEBUGGING.

The unaligned fault mask bit is located in the process control block (PRCB), which is read during initialization. It controls whether unaligned memory accesses are handled by the processor or generate a fault. See section 10.4, "DATA ALIGNMENT" (pg. 10-9).

## 7.8 FAULT HANDLING ACTION

Once a fault occurs the processor saves the program state, calls the fault handling procedure and — when the fault recovery action completes — restores the program state (if possible). No software other than the fault handling procedures is required to support this activity.



Table 7-2. Fault Flags or Masks

| Flag or Mask Name         | Location                          | Faults Affected      |
|---------------------------|-----------------------------------|----------------------|
| Integer Overflow Mask Bit | Arithmetic Controls (AC) Register | Integer Overflow     |
| No Imprecise Faults Bit   | Arithmetic Controls (AC) Register | All Imprecise Faults |
| Trace Enable Bit          | Process Controls (PC) Register    | All Trace Faults     |
| Trace Mode Flags          | Trace Controls (TC) Register      | All Trace Faults     |
| Unaligned Fault Mask      | Process Control Block (PRCB)      | Unaligned Fault      |

**NOTE:**

The unaligned fault, unaligned fault mask and the processor control block are i960 Cx processor extensions to the i960 architecture.

Three different types of implicit procedure calls can be used to invoke the fault handling procedure according to the information in the selected fault table entry: a local call, a system-local call and a system-supervisor call.

The following sections describe actions the processor takes while handling faults. It is not necessary to read these sections to use the fault handling mechanism or to write a fault handling procedure. This discussion is provided for those readers who wish to know the details of the fault handling mechanism.

7

### 7.8.1 Local Fault Call

When the selected fault handler entry in the fault table is an entry type 000 (local procedure), the processor operates as described in section 5.2.3.1, “Call Operation” (pg. 5-5), with the following exceptions:

- A new frame is created on the stack that the processor is currently using. The stack can be the user stack, supervisor stack or interrupt stack.
- The fault record is copied into the area allocated for it in the stack, beginning at NFP-1. (See Figure 7-4.)
- The processor gets the IP for the first instruction in the called fault handling procedure from the fault table.
- The processor stores the fault return code (001<sub>2</sub>) in the PFP return type field.

If the fault handling procedure is not able to perform a recovery action, it performs one of the actions described in section 7.7.2, “Program Resumption Following a Fault” (pg. 7-12).

## FAULTS

If the handler action results in recovery from the fault, a **ret** instruction in the fault handling procedure allows processor control to return to the program that was pending when the fault occurred. Upon return, the processor performs the action described in section 5.2.3.2, “Return Operation” (pg. 5-6), except that the arithmetic controls field from the fault record is copied into the AC register. Since the call made is local, the process controls field from the fault record is not copied back to the PC register.

### 7.8.2 System-Local Fault Call

When the fault handler selects an entry for a local procedure in the system procedure table (entry type 10<sub>2</sub>), the processor performs the same action as is described in the previous section for a local fault call or return. The only difference is that the processor gets the fault handling procedure's address from the system procedure table rather than from the fault table.

### 7.8.3 System-Supervisor Fault Call

When the fault handler selects an entry for a supervisor procedure in the system procedure table, the processor performs the same action described in section 5.2.3.1, “Call Operation” (pg. 5-5), with the following exceptions:

- If in user mode when the fault occurs: the processor switches to supervisor mode, reads the supervisor stack pointer from the system procedure table and switches to the supervisor stack. A new frame is then created on the supervisor stack.
- If in supervisor mode when the fault occurs: the processor creates a new frame on the current stack. If the processor is executing a supervisor procedure when the fault occurred, the current stack is the supervisor stack; if it is executing an interrupt handler procedure, the current stack is the interrupt stack. (The processor switches to supervisor mode when handling interrupts.)
- The fault record is copied into the area allocated for it in the new stack frame, beginning at NFP-1. (See Figure 7-4.)
- The processor gets the IP for the first instruction of the fault handling procedure from the system procedure table (using the index provided in the fault table entry).
- The processor stores the fault return code (001<sub>2</sub>) in the PFP register return type field. If the fault is not a trace fault, it copies the state of the system procedure table trace control flag (byte 12, bit 0) into the PC register trace enable bit. If the fault is a trace fault, the trace enable bit is cleared.

On a return from the fault handling procedure, the processor performs the action described in section 5.2.3.2, “Return Operation” (pg. 5-6) with the following exceptions:



- The fault record arithmetic controls field is copied into the AC register.
  - If the processor is in supervisor mode prior to the return from the fault handling procedure (which it should be), the fault record process controls field is copied into the PC register.
  - If the PC register resume flag is set, the processor reads the resumption record from the stack. (Restoring the PC register restores the trace-fault-pending flag and trace enable bit values to their pre-fault values.)
  - If the processor was in user mode when the fault occurred, the mode is set back to user mode; otherwise, the processor remains in supervisor mode.
- The processor switches back to the stack it was using when the fault occurred. (If the processor was in user mode when the fault occurred, this operation causes a switch from the supervisor stack to the user stack.)
- If the trace-fault-pending flag and trace enable bit are set, the trace fault is also handled at this time.

PC register restoration causes any changes to the process controls caused by the fault handling procedure to be lost. In particular, if the **ret** instruction from the fault handling procedure caused the PC register trace-fault-pending flag to be set, this setting would be lost upon return.

7

#### 7.8.4 Faults and Interrupts

If an interrupt occurs during:

- an instruction that will fault; or
- an instruction that has already faulted; or
- fault handling procedure selection

the processor handles the interrupt in the following way: It completes the selection of the fault handling procedure, then services the interrupt just prior to executing the first instruction of the fault handling procedure. The fault is handled upon return from the interrupt. Handling the interrupt before the fault reduces interrupt latency.

#### 7.9 PRECISE AND IMPRECISE FAULTS

As described in section 7.6.4, “Parallel Faults” (pg. 7-9), the i960 architecture — to support parallel and out-of-order instruction execution — allows some faults to be generated together and not in sequence. When this situation occurs, it may be impossible to recover from some faults, because the state of the instructions surrounding the faulting instruction has changed or the RIP is unpredictable.

## FAULTS

The processor provides two mechanisms for controlling the circumstances under which faults are generated: the AC register no-imprecise-faults bit (NIF bit) and the synchronize-faults instruction (**syncf**). Faults are categorized as precise, imprecise and asynchronous. The following subsections describe each.

### 7.9.1 Precise Faults

Precise faults are those intended to be software recoverable. For any instruction that can generate a precise fault, the processor:

- does not execute the instruction if an unfinished prior instruction will fault, and
- does not execute subsequent out-of-order instructions that will fault.

Also, the RIP points to an instruction where the processor can resume program execution without breaking program control flow. Two faults are always precise: trace faults and protection faults.

### 7.9.2 Imprecise Faults

Imprecise faults are those where the architecture does not guarantee that sufficient information is saved in the fault record to allow recovery from the fault. For imprecise faults, the faulting instruction address is correct, but the state of execution of instructions surrounding the faulting instruction may be unpredictable. Also, the architecture allows imprecise faults to be generated out of order, which means that the RIP may not be of any value for recovery. Faults that the architecture allows to be imprecise include:

- operation
- arithmetic
- constraint
- type

Refer to section 7.10, “FAULT REFERENCE” (pg. 7-20) to determine which faults are precise.

### 7.9.3 Asynchronous Faults

Asynchronous faults are those whose occurrence has no direct relationship to the instruction pointer. The i960 architecture does not define any faults in this category.

### 7.9.4 No Imprecise Faults (NIF) Bit

The NIF bit controls imprecise fault generation. When this bit is set, all faults generated are precise. This means the following conditions hold true:

- All faults are generated in order.
- A precise fault record is provided for each fault: the faulting instruction address is correct and the RIP provides a valid re-entry point into the program.



When the NIF bit is clear, imprecise faults are allowed to be generated: in parallel, out of order and with an imprecise RIP. Here, the following conditions hold true:

- When an imprecise fault occurs, the faulting instruction address in the fault record is valid, but the saved IP is unpredictable.
- If instructions are executed out of order and parallel faults occur, recovery from some faults may not be possible because the faulting instruction's source operands may be modified when subsequent instructions are executed out of order.

### 7.9.5 Controlling Fault Precision

The **syncf** instruction forces the processor to complete execution of all instructions that occur prior to **syncf** and to generate all faults before it begins work on instructions that occur after **syncf**. This instruction has two uses:

- forces faults to be precise when the NIF bit is clear.
- ensures that all instructions are complete and all faults are generated in one block of code before executing another block of code.

Compiled code should execute with the NIF bit clear, using **syncf** where necessary to ensure that faults occur in order. In this mode, imprecise faults are considered as catastrophic errors from which recovery is not needed.

The NIF bit should be set if recovery from one or more imprecise faults is required. For example, the NIF bit should be set if a program needs to handle — and recover from — unmasked integer-overflow faults and the fault handling procedure cannot be closely coupled with the application to perform imprecise fault recovery.

**FAULTS****7.10 FAULT REFERENCE**

This section describes each fault type and subtype and gives detailed information about what is stored in the various fields of the fault record. The section is organized alphabetically by fault type. The following paragraphs describe the information that is provided for each fault type.

|                         |   |
|-------------------------|---|
| Fault Type and Subtype: | Gives the number which appears in the fault record fault-type field when the fault is generated. The fault-subtype section lists fault subtypes and number associated with each fault subtype.  |
| Function:               | Describes the purpose of fault type and fault subtype. It also describes how the processor handles each fault subtype.  |
| RIP:                    | Describes the value saved in the RIP register of the stack frame that the processor was using when the fault occurred. In the RIP definitions, “next instruction” refers to: (1) the instruction directly after the faulting instruction or (2) an instruction to which the processor can logically return when resuming program execution. |
| Program State Changes:  | Describes the effect(s) that a fault subtype causes in a program’s control flow.  |





**7.10.1 Arithmetic Faults**

Fault Type: 3H

|                |               |                        |
|----------------|---------------|------------------------|
| Fault Subtype: | <b>Number</b> | <b>Name</b>            |
|                | 0H            | Reserved               |
|                | 1H            | Integer Overflow       |
|                | 2H            | Arithmetic Zero Divide |
|                | 3H-FH         | Reserved               |

Function: Indicates a problem with an operand or the result of an arithmetic instruction. An integer overflow fault is generated when the result of an integer instruction overflows its destination and the AC register integer overflow mask is cleared. Here, the result's n least significant bits are stored in the destination, where n is destination size. Instructions that generate this fault are:

- addi      subi**
- stib      shli**
- muli      divi**



An arithmetic zero-divide fault is generated when the divisor operand of an ordinal- or integer-divide instruction is zero. Instructions that generate this fault are:

- divo      divi**
- ediv      remi**
- remo**

RIP: IP for next-executed instruction if a fault had not occurred.

Program State Changes: Faults may be imprecise when executing with the NIF bit cleared. An integer overflow fault may not be recoverable because the result is stored in the destination before the fault is generated; e.g., the faulting instruction cannot be re-executed if the destination register was also a source register for the instruction. An arithmetic zero-divide fault is generated before execution of the faulting instruction.



## FAULTS

### 7.10.2 Constraint Faults

Fault Type: 5H

|                |               |                  |
|----------------|---------------|------------------|
| Fault Subtype: | <b>Number</b> | <b>Name</b>      |
|                | 0H            | Reserved         |
|                | 1H            | Constraint Range |
|                | 2H            | Privileged       |
|                | 3H-FH         | Reserved         |

Function: Indicates the program or procedure violated an architectural constraint.

A constraint-range fault is generated when a fault-if instruction is executed and the AC register condition code field matches the condition required by the instruction.

A privileged fault is also generated when the program or procedure attempts to use a privileged (supervisor-mode only) instruction while the processor is in user mode. Privileged instructions for the i960 Cx processor are:

**sdma      sysctl**

RIP: No defined value.

Program State Changes: These faults may be imprecise when executing with the NIF bit cleared. No changes in the program's control flow accompany these faults. A constraint-range fault is generated after the fault-if instruction executes; the program state is not affected. A privileged fault is generated before the faulting instruction executes.



### 7.10.3 Operation Faults

Fault Type: 2H

| Fault Subtype: | <b>Number</b> | <b>Name</b>            |
|----------------|---------------|------------------------|
|                | 0H            | Reserved               |
|                | 1H            | Invalid Opcode         |
|                | 2H            | Unimplemented-Reserved |
|                | 3H            |                        |
|                | 4H            | Invalid Operand        |
|                | 5H - FH       | Reserved               |

Function: Indicates the processor cannot execute the current instruction because of invalid instruction syntax or operand semantics.

An invalid-opcode fault is generated when the processor attempts to execute an instruction containing an undefined opcode or addressing mode. An unimplemented fault is generated when processor attempts to execute an instruction fetched from on-chip data RAM.

An unaligned fault is generated when the following conditions are present: (1) the processor attempts to access an unaligned word or group of words in memory; and (2) a fault is enabled by the unaligned-fault mask bit in the PRCB fault configuration word.

The i960 Cx processors handle unaligned accesses to little endian regions of memory in microcode and carry out the access regardless of the unaligned-fault mask bit setting. The processors do not support unaligned accesses to big endian regions; such attempts result in incoherent data in memory. Enabling the unaligned fault when using big endian byte ordering provides a means of detecting unsupported unaligned accesses.

When an unaligned fault is signaled, the effective address of the unaligned access is placed in the fault record's optional data section, beginning at address NFP-24. This address is useful to debug a program that is making unintentional unaligned accesses.

An invalid-operand fault is generated when the processor attempts to execute an instruction that has one or more operands having special requirements which are not satisfied. A fault is caused by specifying a non-existent SFR or non-defined **sysctl** and/or references to an unaligned long-, triple- or quad-register group.

RIP: No defined value.

Program State Changes: Faults may be imprecise when executing with the NIF bit cleared. A change in the program's control flow does not accompany operation faults; faults occur before instruction execution.



**FAULTS****7.10.4 Parallel Faults**

|                        |   |
|------------------------|---|
| Fault Type:            | See section 7.6.4, “Parallel Faults” (pg. 7-9).   |
| Fault Subtype:         | None; see Figure 7-5., Fault Record for Parallel Faults (pg. 7-11).   |
| Function:              | <p>Indicates that one or more faults occurred when the processor was executing instructions in parallel in different execution units. This fault type can occur only when the AC register NIF bit is cleared.</p> <p>If parallel faults occur, the number-of-parallel-faults field in the fault record is a non-zero value which indicates the number of parallel faults recorded. This field is located in the fault record at location NFP-20.</p> <p>A fault record is saved for each parallel fault detected. Information contained in these records is the same as described in this section for specific fault types.</p> |
| RIP:                   | IP of instruction that would execute next if faults were not generated.   |
| Program State Changes: | Precision of faults recorded in a parallel fault record depends on the fault types detected. A change in the program’s control flow may or may not accompany parallel faults, depending on fault types detected.  |



**7.10.5 Protection Faults**

Fault Type: 7H

|                |               |                 |
|----------------|---------------|-----------------|
| Fault Subtype: | <b>Number</b> | <b>Name</b>     |
|                | 0H-1H         | Reserved        |
|                | 2H            | Length          |
|                | 3H            | Reserved        |
|                | 4H            | SRAM Protection |
|                | 5-FH          | Reserved        |

Function: Indicates a program or procedure is attempting to perform an illegal operation that the architecture protects against.

A length fault is generated when the index operand used in a **calls** instruction points to an entry beyond the extent of the system procedure table.

SRAM protection is generated when a write to the on-chip SRAM is attempted while in user mode.

RIP: Same as the address-of-faulting-instruction field.

Program State Changes: This fault type is always precise, regardless of the NIF bit value. A change in the program's control flow does not accompany a length fault; a fault is generated before the faulting instruction.



## FAULTS

### 7.10.6 Trace Faults

Fault Type: 1H

|                |               |                   |
|----------------|---------------|-------------------|
| Fault Subtype: | <b>Number</b> | <b>Name</b>       |
|                | Bit 0         | Reserved          |
|                | Bit 1         | Instruction Trace |
|                | Bit 2         | Branch Trace      |
|                | Bit 3         | Call Trace        |
|                | Bit 4         | Return Trace      |
|                | Bit 5         | Prereturn Trace   |
|                | Bit 6         | Supervisor Trace  |
|                | Bit 7         | Breakpoint Trace  |

Function: Indicates the processor detected one or more trace events. The event tracing mechanism is described in CHAPTER 8, TRACING AND DEBUGGING.

A trace event is the occurrence of a particular instruction or instruction type in the instruction stream. The processor recognizes seven different trace events: instruction, branch, call, return, prereturn, supervisor, breakpoint. It detects these events only if the TC register mode bit is set for the event. If the PC register trace enable bit is also set, the processor generates a fault when a trace event is detected.

A trace fault is generated following the instruction that causes a trace event (or prior to the instruction for the prereturn trace event). The following trace modes are available:

|                    |  |
|--------------------|--|
| <i>Instruction</i> | Generates a trace event following every instruction.   |
| <i>Branch</i>      | Generates a trace event following any branch instruction when the branch is taken (a branch trace event does not occur on branch-and-link or call instructions).                                   |
| <i>Call</i>        | Generates a trace event following any call or branch-and-link instruction or any implicit procedure call (i.e., fault- or interrupt-call).   |
| <i>Return</i>      | Generates a trace event following a <b>ret</b> .   |
| <i>Prereturn</i>   | Generates a trace event prior to any <b>ret</b> instruction, providing the PFP register prereturn trace flag is set (the processor sets the flag automatically when prereturn tracing is enabled). |



|                   |  |
|-------------------|--|
| <i>Supervisor</i> | Generates a trace event following any <b>calls</b> instruction that references a supervisor procedure entry in the system procedure table and on a return from a supervisor procedure where the return status type in the PFP register is 010 <sub>2</sub> or 011 <sub>2</sub> . |
| <i>Breakpoint</i> | Generates a trace event following any processor action that causes a breakpoint condition (such as a <b>mark</b> or <b>fmark</b> instruction or a match of the instruction-address breakpoint register or the data-address breakpoint register).                                 |

Trace fault subtype and fault subtype field bits are associated with each mode. Multiple fault subtypes can occur simultaneously; the fault subtype bit is set for each subtype that occurs.

When a fault type other than a trace fault is generated during execution of an instruction that causes a trace event, a non-trace fault is handled before a trace fault. An exception is the prereturn-trace fault, which occurs before the processor detects a non-trace fault and is handled first.

7

Similarly, if an interrupt occurs during an instruction that causes a trace event, the interrupt is serviced before the trace fault is handled. Again, the prereturn trace fault is an exception. Since it is generated before the instruction, it is handled before any interrupt that occurs during instruction execution.

The address of the faulting instruction field in the fault record contains the IP for the instruction that causes the trace event. For the prereturn trace fault, this field has no defined value.

RIP: IP for the instruction that would have executed next if the fault had not occurred.

Program State Changes: This fault type is always precise, regardless the NIF bit value. A change in the program's control flow accompanies all trace faults (except the prereturn trace fault), because events that can cause a trace fault to occur after the faulting instruction is completed. As a result, the faulting instruction cannot be re-executed upon returning from the fault handling procedure.

Since the prereturn trace fault is generated before **ret** executes, a change in the program's control flow does not accompany this fault; the faulting instruction can be executed upon returning from the fault handling procedure.

## FAULTS

### 7.10.7 Type Faults

Fault Type: AH

| Fault Subtype: | Number | Name          |
|----------------|--------|---------------|
|                | 0H     | Reserved      |
|                | 1H     | Type Mismatch |
|                | 2H-FH  | Reserved      |

Function: Indicates a program or procedure attempted to perform an illegal operation on an architecture-defined data type or a typed data structure. A type-mismatch fault is generated when attempts are made to:

- Modify the PC register with **modpc** while the processor is in user mode.
- Write to on-chip data RAM while the processor is in user mode.
- Access a special function register while the processor is in user mode.

RIP: No defined value.

Program State Changes: These faults may be imprecise when executing with the NIF bit cleared. A change in the program's control flow does not accompany the type-mismatch fault because the fault occurs before execution of the faulting instruction.





# TRACING AND DEBUGGING





## CHAPTER 8

# TRACING AND DEBUGGING

This chapter describes the i960<sup>®</sup> Cx processors' facilities for runtime activity monitoring.

The i960 architecture provides facilities for monitoring processor activity through trace event generation. A trace event indicates a condition where the processor has just completed executing a particular instruction or type of instruction or where the processor is about to execute a particular instruction. When the processor detects a trace event, it generates a trace fault and makes an implicit call to the fault handling procedure for trace faults. This procedure can, in turn, call debugging software to display or analyze the processor state when the trace event occurred. This analysis can be used to locate software or hardware bugs or for general system monitoring during program development.

Tracing is enabled by the process controls (PC) register trace enable bit and a set of trace mode bits in the trace controls (TC) register. Alternatively, the **mark** and **fmark** instructions can be used to generate trace events explicitly in the instruction stream.

The i960 Cx processors also provide four hardware breakpoint registers that generate trace events and trace faults. Two registers are dedicated to trapping on instruction execution addresses, while the remaining two registers can trap on the addresses of various types of data accesses.

8

### 8.1 TRACE CONTROLS

To use the architecture's tracing facilities, software must provide trace fault handling procedures, perhaps interfaced with a debugging monitor. Software must also manipulate the following registers and control bits to enable the various tracing modes and enable or disable tracing in general. These controls are described in the following sub-sections.

- TC register mode bits
- PC register trace fault pending flag
- System procedure table supervisor-stack-pointer field trace control bit
- IPB0-IPB1 registers' address field (in the control table)
- PC register trace enable bit
- PFP register return status field prereturn trace flag (bit 0)
- BPCON register breakpoint mode bits and enable bits (in the control table)
- DAB0-DAB1 registers' address field and enable bit (in the control table)

### 8.1.1 Trace Controls (TC) Register

The TC register (Figure 8-1) allows software to define conditions which generate trace events.

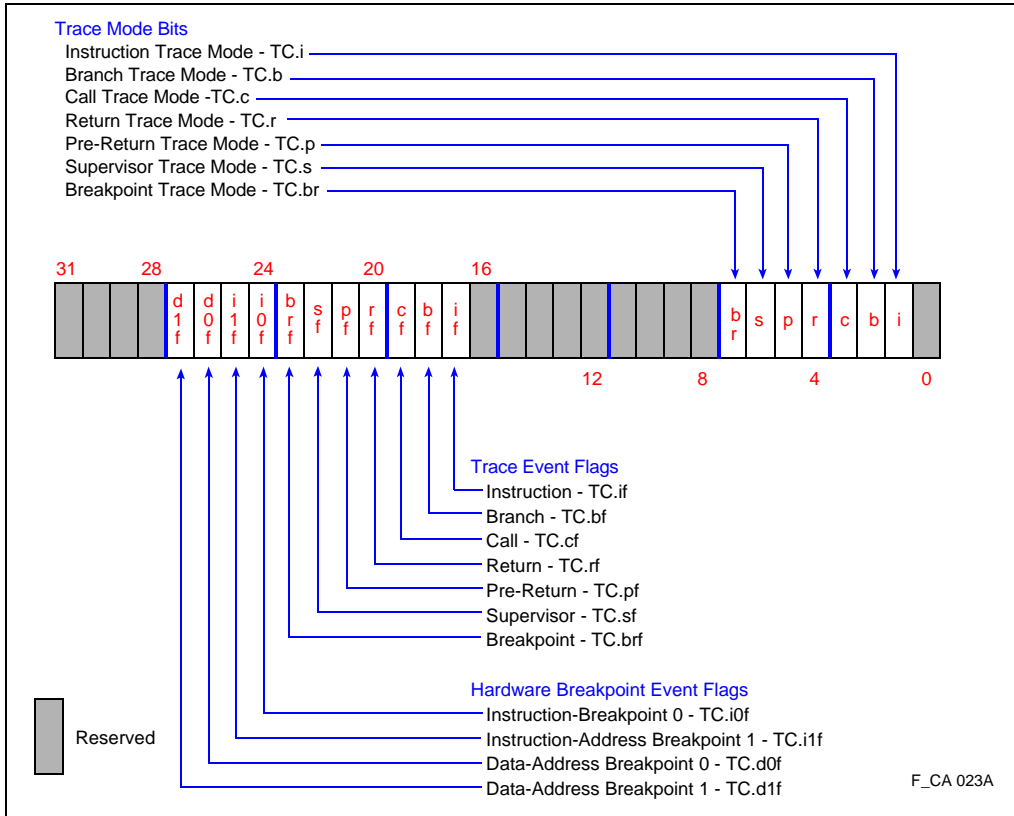


Figure 8-1. Trace Controls (TC) Register

The TC register contains mode bits and event flags. Mode bits define a set of tracing conditions that the processor can detect. For example, when the call-trace mode bit is set, the processor generates a trace event when a call or branch-and-link operation executes. See section 8.2 (pg. 8-4). The processor uses event flags to monitor which trace events are generated.

A special instruction, the modify-trace-controls (**modtc**) instruction, allows software to modify the TC register. On initialization, all TC register bits and flags are cleared. **modtc** can then be used to set or clear trace mode bits as required. Software can also access event flags using **modtc**; however, this is generally not necessary. The processor automatically sets and clears these flags as part of its trace handling mechanism. TC register bits 0, 8 through 16 and 28 through 31 are reserved. Software must initialize these bits to zero and not modify them afterwards.



### 8.1.2 Trace Enable Bit and Trace-Fault-Pending Flag

The PC register trace enable bit and the trace-fault-pending flag — located in the process controls register — control tracing. The trace enable bit enables the processor's tracing facilities; when set, the processor generates trace faults on all trace events.

Typically, software selects the trace modes to be used through the TC register. It then sets the trace enable bit to begin tracing. This bit is also altered as part of some call and return operations that the processor performs as described in section 8.6.3, "Tracing and Interrupt Procedures" (pg. 8-9).

The trace-fault-pending flag allows the processor to track when a trace event is detected for an enabled trace condition. The processor uses this flag as follows:

1. When the processor detects a trace event and tracing is enabled, it sets the flag.
2. Before executing an instruction, the processor checks the flag.
3. If the flag is set and tracing is enabled, it signals a trace fault.

By providing a means to record trace event occurrences, the trace-fault-pending flag allows the processor to service an interrupt or handle a fault other than a trace fault before handling the trace fault. Software should not modify this flag.

**8**

### 8.1.3 Trace Control on Supervisor Calls

The trace control bit allows tracing to be enabled or disabled when a call-system instruction (**calls**) executes, which results in a switch to supervisor mode. This action occurs independent of whether or not tracing is enabled prior to the call. A supervisor call is a calls instruction that references an entry in the system procedure table with an entry type 010<sub>2</sub>. When a supervisor call executes, the processor:

1. Saves current PC register trace enable bit status in the PFP register return-type field bit 0.
2. Sets the PC register trace enable bit to the value of the trace control bit. The processor gets the trace control bit from bit 0 of the supervisor stack pointer, which is cached during the reset initialization sequence.

When the trace control bit is set, tracing is enabled on supervisor calls; when cleared, tracing is disabled on supervisor calls. Upon return from the supervisor procedure, the PC register trace enable bit is restored to the value saved in the PFP register return-type field.

## 8.2 TRACE MODES

This section defines trace modes enabled through the TC register. These modes can be enabled individually or several modes can be enabled at once. Some modes overlap, such as call-trace mode and supervisor-trace mode. section 8.4, “HANDLING MULTIPLE TRACE EVENTS” (pg. 8-8) describes processor function when multiple trace events occur.

- Instruction trace
- Branch trace
- Breakpoint trace
- Prereturn trace
- Call trace
- Return trace
- Supervisor trace

### 8.2.1 Instruction Trace

When the instruction-trace mode is enabled, the processor generates an instruction-trace event each time an instruction executes. A debug monitor can use this mode to single-step the processor.

### 8.2.2 Branch Trace

When the branch-trace mode is enabled, the processor generates a branch-trace event when a branch instruction executes and the branch is taken. A branch-trace event is not generated for conditional-branch instructions that do not branch for branch-and-link, call or return instructions.

### 8.2.3 Call Trace

When the call-trace mode is enabled, the processor generates a call-trace event when a call instruction (**call**, **callx** or **calls**) or a branch-and-link instruction (**bal** or **balx**) executes. An implicit call — such as the action used to invoke a fault handling or an interrupt handling procedure — also causes a call-trace event to be generated.

When the processor detects a call-trace event, it sets the prereturn-trace flag (PFP register bit 3) in the new frame created by the call operation or — if a branch-and-link operation was performed — it sets this flag in the current frame. The processor uses this flag to determine when to signal a prereturn-trace event on a **ret** instruction.

### 8.2.4 Return Trace

When the return-trace mode is enabled, the processor generates a return-trace event any time a **ret** instruction executes.



### 8.2.5 Prereturn Trace

The prereturn-trace mode causes the processor to generate a prereturn-trace event prior to **ret** execution, providing the PFP register prereturn-trace flag is set. (Prereturn tracing cannot be used without enabling call tracing.) The processor sets the prereturn-trace flag whenever it detects a call-trace event as described above for call-trace mode. This flag performs a prereturn-trace-pending function.

If another trace event occurs at the same time as the prereturn-trace event, the processor generates a fault on the non-prereturn-trace event first. Then, on a return from that fault handler, it generates a fault on the prereturn-trace event. The prereturn trace is the only trace event that can cause two successive trace faults to be generated between instruction boundaries.

### 8.2.6 Supervisor Trace

When supervisor-trace mode is enabled, the processor generates a supervisor-trace event when:

- a call-system instruction (**calls**) executes, where the procedure table entry is for a system-supervisor call; or
- a **ret** instruction executes and the return-type field is set to 010<sub>2</sub> or 011<sub>2</sub> (i.e., return from supervisor mode).

When these procedures are called with supervisor calls, this trace mode allows a debugging program to determine kernel-procedure call boundaries within the instruction stream.

### 8.2.7 Breakpoint Trace

Breakpoint trace mode allows trace events to be generated at places other than those specified with the other trace modes. This mode is used in conjunction with **mark** and **fmark**.

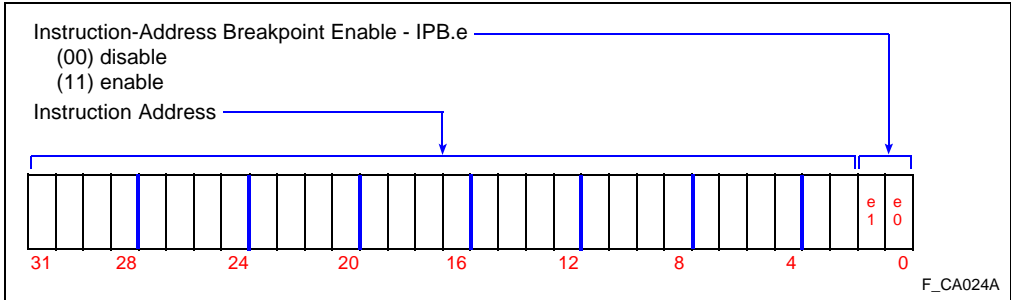
#### 8.2.7.1 Software Breakpoints

**mark** and **fmark** allow breakpoint trace events to be generated at specific points in the instruction stream. When breakpoint trace mode is enabled, the processor generates a breakpoint trace event any time it encounters a mark. **fmark** causes the processor to generate a breakpoint trace event regardless of whether or not breakpoint trace mode is enabled.

#### 8.2.7.2 Hardware Breakpoints

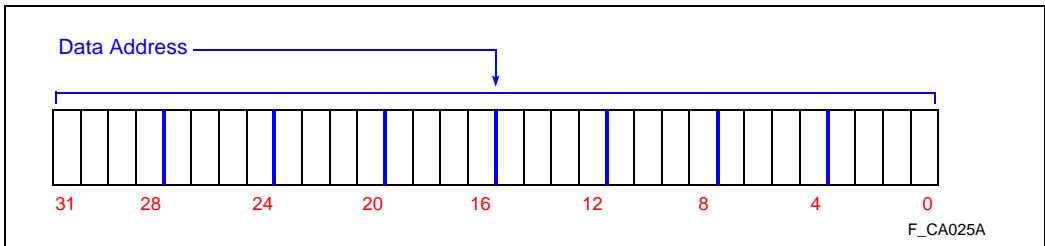
The hardware breakpoint registers are provided to enable generation of trace events and trace faults on instruction addresses and data access addresses.

Breakpoint trace events can be generated when the processor executes an instruction with an IP that matches one of the addresses programmed into the two instruction breakpoint registers (IPB0-IPB1). Each instruction address breakpoint may be enabled or disabled individually by programming the two least significant bits in IPB0 or IPB1. Figure 8-2 describes the instruction address breakpoint registers.



**Figure 8-2. Instruction Address Breakpoint Registers (IPB0 - IPB1)**

Breakpoint trace events may also be generated when a memory access is issued which matches conditions programmed in one of two data address breakpoint registers (DAB0 - DAB1, see Figure 8-3). Each breakpoint register is programmed to fault when the address of an access matches the breakpoint register and the access is one of four types: (1) any store, (2) any load or store, (3) any data load or store or any instruction fetch or (4) any memory access.



**Figure 8-3. Data Address Breakpoint Registers (DAB0 - DAB1)**

The programmer configures the BPCON register to set the data address breakpoint mode which corresponds to one of these access types (Figure 8-4). Each data address breakpoint may also be enabled or disabled individually by programming the BPCON enable bits.

The instruction-address breakpoint, data-address breakpoint and breakpoint control registers are on-chip control registers. These are loaded from the control table in memory at initialization or may be modified using **sysctl**. Control registers are described in section 2.3, “CONTROL REGISTERS” (pg. 2-6); **sysctl** is further described in section 4.3, “SYSTEM CONTROL FUNCTIONS” (pg. 4-19).





A breakpoint trace event is signalled when the processor attempts an access which is set for detection (instruction or data breakpoint). Breakpoint trace is enabled by setting the appropriate field in the IPB0, IPB1 and BPCON registers. If breakpoint trace is enabled, the appropriate TC register hardware breakpoint trace event flags are set. If tracing is enabled, a trace fault is generated after the faulting instruction completes execution.

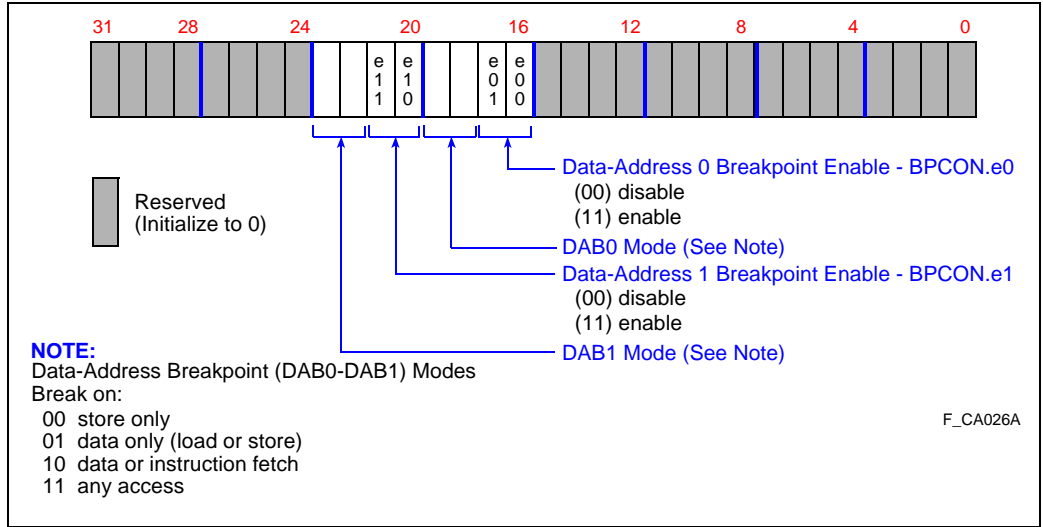


Figure 8-4. Hardware Breakpoint Control Register (BPCON)

### 8.3 SIGNALING A TRACE EVENT

To summarize the information presented in the previous sections, the processor signals a trace event when it detects any of the following conditions:

- An instruction included in a trace mode group executes or is about to execute (in the case of a prereturn trace event) and the trace mode for that instruction is enabled.
- An implicit call operation executed and the call-trace mode is enabled.
- A **mark** instruction executed and the breakpoint-trace mode is enabled.
- An **fmark** instruction executed.
- The processor is executing an instruction at an IP matching an enabled instruction address breakpoint register.
- The processor has issued a memory access matching the conditions of an enabled data address breakpoint register.



## TRACING AND DEBUGGING

When the processor detects a trace event and the PC register trace enable bit is set, the processor performs the following action:

1. The processor sets the appropriate TC register trace event flag. If a trace event meets the conditions of more than one of the enabled trace modes, a trace event flag is set for each trace mode condition that is met.
2. The processor sets the PC register trace-fault-pending flag. The processor may set a trace event flag and trace-fault-pending flag before completing execution of the instruction that caused the event. However, the processor only handles trace events between instruction executions.

If — when the processor detects a trace event — the PC register trace enable bit is clear, the processor sets the appropriate event flags but does not set the PC register trace-fault-pending flag.

### 8.4 HANDLING MULTIPLE TRACE EVENTS

If the processor detects multiple trace events, it records one or more of them based on the following precedence, where 1 is the highest precedence:

1. Supervisor-trace event
2. Breakpoint- (from **mark** or **fmark** instruction or from a breakpoint register), branch-, call- or return-trace event
3. Instruction-trace event

When multiple trace events are detected, the processor may not signal each event; however, it always signals the one with the highest precedence.

### 8.5 TRACE FAULT HANDLING PROCEDURE

The processor calls the trace fault handling procedure when it detects a trace event. See section 7.7, “FAULT HANDLING PROCEDURES” (pg. 7-12) for general requirements for fault handling procedures.

The trace fault handling procedure is involved in a specific way and is handled differently than other faults. A trace fault handler must be involved with an implicit system-supervisor call. When the call is made, the PC register trace enable bit is cleared. This disables trace faults when the trace fault handler is executing. Recall that, for all other implicit or explicit system-supervisor calls, the trace enable bit is replaced with the system procedure table trace control bit. The



exceptional handling of trace enable for trace faults ensures that tracing is turned off when a trace fault handling procedure is being executed. This is necessary to prevent an endless loop of trace fault handling calls.

## 8.6 TRACE HANDLING ACTION

Once a trace event is signaled, the processor determines how to handle the trace event, according to the PC register trace enable bit and trace fault pending flag settings and to other events that might occur simultaneously with the trace event, such as an interrupt or non-trace fault. Subsections that follow describe how the processor handles trace events for various situations.

### 8.6.1 Normal Handling of Trace Events

Before the processor executes an instruction:

1. The processor checks the state of the trace fault pending flag:
  - If clear, the processor begins execution of the next instruction.
  - If set, the processor performs the following actions.
2. The processor checks the PC register trace enable bit state:
  - If clear, the processor clears any trace event flags that are set prior executing the next instruction.
  - If set, the processor signals a trace fault and begins fault handling action as described in section 7.7, “FAULT HANDLING PROCEDURES” (pg. 7-12).

**8**

### 8.6.2 Prereturn Trace Handling

The processor handles a prereturn trace event the same as described above except when it occurs at the same time as a non-trace fault. In this case, the non-trace fault is handled first. On returning from the fault handler for the non-trace fault, the processor checks the PFP register prereturn trace flag. If set, the processor generates a prereturn trace event, then handles it as described in section 8.6.1, “Normal Handling of Trace Events” (pg. 8-9).

### 8.6.3 Tracing and Interrupt Procedures

When the processor invokes an interrupt handling procedure to service an interrupt, it disables tracing. It does this by saving the PC register’s current state, then clearing the PC register trace enable bit and trace fault pending flag.

## TRACING AND DEBUGGING

On returning from the interrupt handling procedure, the processor restores the PC register to the state it was in prior to handling the interrupt, which restores the trace enable bit and trace fault pending flag states. If these two flags were set prior to calling the interrupt procedure, a trace fault is signaled on return from the interrupt procedure.

### NOTE:

On a return from an interrupt handling procedure, the trace fault pending flag is restored. If this flag was set as a result of the interrupt procedure's **ret** instruction (i.e., indicating a return trace event), the detected trace event is lost. This is also true on a return from a fault handler, when the fault handler is called with an implicit supervisor call.





# 9

## INSTRUCTION SET REFERENCE





# CHAPTER 9

## INSTRUCTION SET REFERENCE

This chapter provides detailed information about each instruction available to the i960<sup>®</sup> Cx processors. Instructions are listed alphabetically by assembly language mnemonic. Format and notation used in this chapter are defined in section 9.2, “NOTATION” (pg. 9-1).

### 9.1 INTRODUCTION

Information in this chapter is oriented toward programmers who write assembly language code for the i960 Cx processors. The information provided for each instruction includes:

- Alphabetic listing of all instructions
- Description of the instruction’s operation
- Faults that can occur during execution
- Opcode and instruction encoding format
- Assembly language mnemonic, name and format
- Action (or algorithm) and other side effects of executing an instruction
- Assembly language example
- Related instructions

Additional information about the instruction set can be found in the following chapters and appendices in this manual:

- CHAPTER 4, INSTRUCTION SET SUMMARY - Summarizes the instruction set by group and describes the assembly language instruction format.
- APPENDIX D, MACHINE-LEVEL INSTRUCTION FORMATS - Describes instruction set opword encodings.
- APPENDIX E, MACHINE LANGUAGE INSTRUCTION REFERENCE - A quick-reference listing of instruction encodings assists debug with a logic analyzer.
- INSTRUCTION SET QUICK REFERENCE - (order #272220; included as an addendum to this manual) A tabular quick reference of each instruction’s operation.

### 9.2 NOTATION

In general, notation in this chapter is consistent with usage throughout the manual; however, there are a few exceptions. Read the following subsections to understand notations that are specific to this chapter.



## INSTRUCTION SET REFERENCE

## 9.2.1 Alphabetic Reference

Instructions are listed alphabetically by assembly language mnemonic. If several instructions are related and fall together alphabetically, they are described as a group on a single page.

The instruction's assembly language mnemonic is shown in bold at the top of the page (e.g., **subc**). Occasionally, it is not practical to list all mnemonics at the page top. In these cases, the name of the instruction group is shown in capital letters (e.g., **BRANCH IF** or **FAULT IF**).

The i960 Cx processor-specific extensions to the i960 microprocessor instruction set are indicated with a box around the instruction's alphabetic reference. The following i960 Cx processor's instructions are such extensions:

|               |             |
|---------------|-------------|
| <b>eshro</b>  | <b>sdma</b> |
| <b>sysctl</b> | <b>udma</b> |

Instruction set extensions are generally not portable to other i960 processor family implementations.

## 9.2.2 Mnemonic

The Mnemonic section gives the mnemonic (in boldface type) and instruction name for each instruction covered on the page, for example:

**subi**      Subtract Integer

CTRL and COBR format instructions also allow the programmer to specify optional .t or .f mnemonic suffixes for branch prediction:

- .t indicates to the processor that the condition the instruction is testing for is likely to be true.
- .f indicates that the condition is likely to be false.

The processor uses the programmer's prediction to prefetch and decode instructions along the most likely execution path when the actual path is not yet known. If the prediction was wrong, all actions along the incorrect path are undone and the correct path is taken. For further discussion, see section A.2.7.7, "Branch Prediction" (pg. A-53).

When the programmer provides no suffix with an instruction which supports a suffix, the assembler makes its own prediction.

When an instruction supports prediction, the mnemonic listing includes the notation {.t|.f} to indicate the option, for example:

**be{.t|.f}**      Branch If Equal





### 9.2.3 Format

The *Format* section gives the instruction's assembly language format and allowable operand types. Format is given in two or three lines. The following is a two line format example:

```

sub*      src1      src2      dst
           reg/lit/sfr  reg/lit/sfr  reg/sfr

```

The first line gives the assembly language mnemonic (boldface type) and operands (italics). When the format is used for two or more instructions, an abbreviated form of the mnemonic is used. An \* (asterisk) at the end of the mnemonic indicates a variable: in the above example, **sub\*** is either **subi** or **subo**.

Operand names are designed to describe operand function (e.g., *src*, *len*, *mask*).

The second line shows allowable entries for each operand. Notation is as follows:

|      |   |
|------|---|
| reg  | Global (g0 ... g15) or local (r0 ... r15) register        |
| lit  | Literal of the range 0 ... 31                             |
| sfr  | Special Function Register (sf0 ... sf2)                   |
| disp | Signed displacement of range $(-2^{22} \dots 2^{22} - 1)$ |
| mem  | Address defined with the full range of addressing modes   |

#### NOTE:

For future implementations, the i960 architecture will allow up to 32 Special Function Registers (SFRs). However, sf0, sf1 and sf2 are the only SFRs implemented on the i960 Cx processors.

In some cases, a third line is added to show register or memory location contents. For example, it may be useful to know that a register is to contain an address. The notation used in this line is as follows:

|      |                   |
|------|-------------------|
| addr | Address           |
| efa  | Effective Address |

### 9.2.4 Description

The *Description* section is a narrative description of the instruction's function and operands. It also gives programming hints when appropriate.

### 9.2.5 Action

The *Action* section gives an algorithm written in a pseudo-code that describes direct effects and possible side effects of executing an instruction. Algorithms document the instruction's net effect on the programming environment; they do not necessarily describe how the processor actually implements the instruction. For example, **shli** requires seven lines of pseudo-code to completely describe its function. Although it might appear from the algorithm that the instruction should take multiple clocks to execute, the i960 Cx processors execute the instruction in a single clock.

The following is an example of the action algorithm for the **alterbit** instruction:

```
if ((AC.cc1 = 0) = 0)
    dst ← src andnot ( $2^{(bitpos \bmod 32)}$ );
    else dst ← src or ( $2^{(bitpos \bmod 32)}$ );
```

$2^{(bitpos \bmod 32)}$  is equivalent to  $2^{(bitpos \bmod 32)}$ .

Table 9-1 defines each abbreviation used in the instruction reference pseudo-code. Table 9-2 explains the symbols used in the pseudo-code.

Since special function registers (*sfr*) may change independent of instruction execution, the following distinctions are important when interpreting the algorithm of any instruction which references a *sfr*:

1. When a source operand is a *sfr* and referenced more than once in an algorithm, the operand's value at every reference is the same as the first reference. In other words, the instruction operates as if the *sfr* was actually read only once, at the beginning of the instruction.
2. When the same *sfr* is specified as the source for multiple operands of the same instruction, the instruction operates as if the source *sfr* was actually read only once, at the beginning of the instruction. When either source operand appears in the action algorithm, the single operand value is used.
3. When a *sfr* is specified as a destination and the algorithm indicates more than one modification of the destination, the instruction operates as if the *sfr* were written only once, at the end of the instruction.



**Table 9-1. Abbreviations in Pseudo-code**

|          |  |
|----------|--|
| AC.xxx   | Arithmetic Controls Register fields<br>AC.cc                   Condition Code flags (AC.cc2:0)<br>AC.cc0                 Condition Code Bit 0<br>AC.cc1                 Condition Code Bit 1<br>AC.cc2                 Condition Code Bit 2<br>AC.nif                 No Imprecise Faults flag<br>AC.of                  Integer Overflow flag<br>AC.om                  Integer Overflow Mask Bit   |
| PC.xxx   | Process Controls Register fields<br>PC.em                 Execution Mode flag<br>PC.s                  State Flag<br>PC.tfp                 Trace Fault Pending flag<br>PC.p                  Priority Field (PC.p5:0)<br>PC.te                 Trace Enable Bit   |
| TC.xxx   | Trace Controls Register fields<br>TC.i                  Instruction Trace Mode Bit<br>TC.c                  Call Trace Mode Bit<br>TC.p                  Pre-return Trace Mode Bit<br>TC.br                 Breakpoint Trace Mode Bit<br>TC.b                  Branch Trace Mode Bit<br>TC.r                  Return Trace Mode Bit<br>TC.s                  Supervisor Trace Mode Bit<br>TC.if                 Instruction Trace Event flag<br>TC.cf                 Call Trace Event flag<br>TC.pf                 Pre-return Trace Event flag<br>TC.brf                Breakpoint Trace Event flag<br>TC.bf                 Branch Trace Event flag<br>TC.rf                 Return Trace Event flag<br>TC.sf                 Supervisor Trace Event flag |
| PF.P.xxx | Previous Frame Pointer (r0)<br>PF.P.add             Address (PF.P.add31:4)<br>PF.P.rt               Return Type Field (PF.P.rt2:0)<br>PF.P.p                Pre-return Trace flag  |
| sp       | Stack Pointer (r1)   |
| fp       | Frame Pointer (g15)  |
| rip      | Return Instruction Pointer (r2)  |
| SPT      | System Procedure Table<br>SPT.base            Supervisor Stack Base Address<br>SPT( <i>targ</i> )           Address of SPT Entry <i>targ</i>   |



**Table 9-2. Pseudo-code Symbol Definitions**

|                   |  |
|-------------------|--|
| ←                 | Assignment   |
| =, ≠              | Comparison: equal, not equal   |
| <, >              | less than, greater than  |
| ≤, ≥              | less than or equal to, greater than or equal to  |
| <<, >>            | Logical Shift  |
| ^                 | Exponentiation   |
| and, or, not, xor | Bitwise Logical Operations   |
| mod               | Modulo   |
| +, -              | Addition, Subtraction  |
| *                 | Multiplication (Integer or Ordinal)  |
| /                 | Division (Integer or Ordinal)  |
| # . .             | Comment delimiter  |
| memory()          | Memory access of specified width<br>memory_{byte short word long triple quad}()<br>memory() Width implied by context |

**9.2.6 Faults**

The *Faults* section lists faults that can be signaled as a direct result of instruction execution. Table 9-3 shows two possible faulting conditions that are common to the entire instruction set and could directly result from any instruction. These fault types are not included in the instruction reference. Table 9-4 shows three possible faulting conditions that are common to large subsets of the instruction set. Other instructions can generate faults in addition to those shown in the following tables. If an instruction can generate a fault, it is noted in that instruction’s *Faults* section.

**Table 9-3. Fault Types and Subtypes**

| Fault Type | Subtype              | Description  |
|------------|----------------------|--|
| Trace      | <i>Instruction</i>   | An Instruction Trace Event is signaled after instruction completion. A Trace fault is generated if both PC.te and TC.i=1.  |
|            | <i>Breakpoint</i>    | A Breakpoint Trace Event is signaled after completion of an instruction for which there is a hardware breakpoint condition match and TC.br is set. A Trace fault is generated if PC.te and TC.br are both=1. |
| Operation  | <i>Unimplemented</i> | An attempt to execute any instruction fetched from internal data RAM causes an operation unimplemented fault.  |



**Table 9-4. Common Possible Faulting Conditions**

| Fault Type | Subtype              | Description  |
|------------|----------------------|--|
| Type       | <i>Mismatch</i>      | Any instruction that references a special function register while not in supervisor mode causes a type mismatch fault.   |
|            | <i>Mismatch</i>      | Any instruction that attempts to write to internal data RAM while not in supervisor mode causes a type mismatch fault.   |
| Operation  | <i>Unimplemented</i> | Any instruction that causes an unaligned memory access causes an operation unimplemented fault if unaligned faults are not masked in the Processor Control Block (PRCB). |

**9.2.7 Example**

The *Example* section gives an assembly language example of an application of the instruction.

**9.2.8 Opcode and Instruction Format**

The *Opcode and Instruction Format* section gives the opcode and instruction encoding format for each instruction, for example:

```
subi    593H    REG
```

The opcode is given in hexadecimal format. The instruction encoding format is one of four possible formats: REG, COBR, CTRL and MEM. Refer to APPENDIX D, MACHINE-LEVEL INSTRUCTION FORMATS for more information on the formats.



**9.2.9 See Also**

The *See Also* section gives the mnemonics of related instructions which are also alphabetically listed in this chapter.

**9.3 INSTRUCTIONS**

This section contains reference information on the processor’s instructions. It is arranged alphabetically by instruction or instruction group.



### 9.3.1 **addc**

Mnemonic: **addc** Add Ordinal With Carry

Format: **addc** *src1*, *src2*, *dst*  
 reg/lit/sfr reg/lit/sfr reg/sfr

Description: Adds *src2* and *src1* values and condition code bit 1 (used here as a carry in) and stores the result in *dst*. If ordinal addition results in a carry, condition code bit 1 is set; otherwise, bit 1 is cleared. If integer addition results in an overflow, condition code bit 0 is set; otherwise, bit 0 is cleared. Regardless of addition results, condition code bit 2 is always set to 0.

**addc** can be used for ordinal or integer arithmetic. **addc** does not distinguish between ordinal and integer source operands. Instead, the processor evaluates the result for both data types and sets condition code bits 0 and 1 accordingly.

An integer overflow fault is never signaled with this instruction.

Action:  $dst \leftarrow src2 + src1 + AC.cc1;$   
 $AC.cc \leftarrow 0CV_2;$   
 # C is carry from ordinal addition  
 # V = 1 if integer addition would have generated an overflow.

Faults: Type *Mismatch*. Non-supervisor reference of a *sfr*.

Example: # Example of double-precision arithmetic  
 # Assume 64-bit source operands  
 # in g0,g1 and g2,g3  
 cmpo 1, 0 # clears Bit 1 (carry bit) of  
 # the AC.cc  
 addc g0, g2, g0 # add low-order 32 bits;  
 #  $g0 \leftarrow g2 + g0 + \text{Carry Bit}$   
 addc g1, g3, g1 # add high-order 32 bits;  
 #  $g1 \leftarrow g3 + g1 + \text{Carry Bit}$   
 # 64-bit result is in g0, g1

Opcode: **addc** 5B0H REG

See Also: **addi, addo, subc, subi, subo**



### 9.3.2 **addi, addo**

Mnemonic:     **addi**       Add Integer  
                   **addo**       Add Ordinal

Format:         **add\***       *src1*,           *src2*,           *dst*  
                                   reg/lit/sfr        reg/lit/sfr        reg/sfr

Description:    Adds *src2* and *src1* values and stores the result in *dst*. The binary results from these two instructions are identical. The only difference is that **addi** can signal an integer overflow.

Action:          $dst \leftarrow src2 + src1;$

Faults:         Type         *Mismatch*. Non-supervisor reference of a *sfr*.  
                   Arithmetic   *Integer Overflow*. Result too large for destination register (**addi** only). If overflow occurs and AC.om =1, fault is suppressed and AC.of is set to 1. Least significant 32-bits of the result are stored in *dst*.

Example:        **addi** r4, g5, r9   # r9 ← g5 + r4

Opcode:         **addi**       591H           REG  
                   **addo**       590H           REG

See Also:       **addc, subi, subo, subc**



### 9.3.3 alterbit

|              |  |  |                             |                       |
|--------------|--|--|-----------------------------|-----------------------|
| Mnemonic:    | <b>alterbit</b>  | Alter Bit  |                             |                       |
| Format:      | <b>alterbit</b>  | <i>bitpos</i> ,<br>reg/lit/sfr                               | <i>src</i> ,<br>reg/lit/sfr | <i>dst</i><br>reg/sfr |
| Description: | Copies <i>src</i> value to <i>dst</i> with one bit altered. <i>bitpos</i> operand specifies bit to be changed; condition code determines value to which the bit is set. If condition code is $X1X_2$ bit 1 = 1, selected bit is set; otherwise, it is cleared. |  |                             |                       |
| Action:      | <b>if</b> (AC.cc1= 0)<br>$dst \leftarrow src \text{ andnot } 2^{(bitpos \bmod 32)}$ ;<br><b>else</b><br>$dst \leftarrow src \text{ or } 2^{(bitpos \bmod 32)}$ ;   |  |                             |                       |
| Faults:      | Type   | <i>Mismatch</i> . Non-supervisor reference of a <i>sfr</i> . |                             |                       |
| Example:     | # assume AC.cc = $010_2$<br>alterbit 24, g4,g9 # g9 ← g4, with bit 24 set  |  |                             |                       |
| Opcode:      | <b>alterbit</b>  | 58FH   | REG                         |                       |
| See Also:    | <b>chkbit, clrbit, notbit, setbit</b>  |  |                             |                       |





### 9.3.4 and, andnot

Mnemonic:     **and**           And  
                  **andnot**       And Not

Format:         **and**           *src1*,           *src2*,           *dst*  
                                   reg/lit/sfr        reg/lit/sfr        reg/sfr  
                   **andnot**       *src1*,           *src2*,           *dst*  
                                   reg/lit/sfr        reg/lit/sfr        reg/sfr

Description:     Performs a bitwise AND (**and**) or AND NOT (**andnot**) operation on *src2* and *src1* values and stores result in *dst*. Note in the action expressions below, *src2* operand comes first, so that with **andnot** the expression is evaluated as:

{ *src2* **andnot** (*src1*) }  
 rather than  
                   { *src1* **andnot** (*src2*) }.

Action:         **and**:           *dst* ← *src2* **and** *src1*;  
                   **andnot**:       *dst* ← *src2* **andnot** (*src1*);

Faults:         Type           *Mismatch*. Non-supervisor reference of a *sfr*.

Example:        **and** 0x17, g8, g2        # g2 ← g8 AND 0x17  
                   **andnot** r3, r12, r9     # r9 ← r12 AND NOT r3

Opcode:         **and**           581H           REG  
                   **andnot**       582H           REG

See Also:       **nand, nor, not, notand, notor, or, ornot, xnor, xor**



### 9.3.5 **atadd**

|              |   |   |                             |                       |
|--------------|---|---|-----------------------------|-----------------------|
| Mnemonic:    | <b>atadd</b>  | Atomic Add  |                             |                       |
| Format:      | <b>atadd</b>  | <i>src/dst</i> ,<br>reg/sfr<br>addr   | <i>src</i> ,<br>reg/lit/sfr | <i>dst</i><br>reg/sfr |
| Description: | <p>Adds <i>src</i> value (full word) to value in the memory location specified with <i>src/dst</i> operand. Initial value from memory is stored in <i>dst</i>.</p> <p>Memory read and write are done atomically (i.e., other processors must be prevented from accessing the word of memory containing the word specified by <i>src/dst</i> operand until operation completes).</p> <p>Memory location in <i>src/dst</i> is the word's first byte (LSB) address. Address is automatically aligned to a word boundary. (Note that <i>src/dst</i> operand maps to <i>src1</i> operand of the REG format.)</p> |   |                             |                       |
| Action:      | <pre>tempa ← <i>src/dst</i> <b>andnot</b> (0x3);    # force alignment to word boundary temp ← memory_word (tempa);      # <math>\overline{\text{LOCK}}</math> asserted at begin of read memory_word (tempa) ← temp + <i>src</i>; # ordinal addition                                    # <math>\overline{\text{LOCK}}</math> deasserted after memory write dst ← temp;</pre>  |   |                             |                       |
| Faults:      | Type  | <i>Mismatch</i> . Non-supervisor reference of a <i>sfr</i> . And/or non-supervisor attempt to write to internal data RAM. |                             |                       |
| Example:     | <pre>atadd r8, r2, r11    # r8 ← r2 + address r8, where                     # r8 specifies the address of a                     # word in memory;                     # r11 ← initial value, stored                     # at address r8 in memory</pre>   |   |                             |                       |
| Opcode:      | <b>atadd</b>  | 612H  | REG                         |                       |
| See Also:    | <b>atmod</b>  |   |                             |                       |



### 9.3.6 **atmod**

Mnemonic: **atmod** Atomic Modify

Format: **atmod** *src* *mask* *src/dst*  
 reg/sfr reg/lit/sfr reg/sfr  
 addr

Description: Copies the selected bits of *src/dst* value into memory location specified in *src*. Bits set in *mask* operand select bits to be modified in memory. Initial value from memory is stored in *src/dst*.

Memory read and write are done atomically (i.e., other processors must be prevented from accessing the quad-word of memory containing the word specified with the *src/dst* operand until operation completes).

Memory location in *src* is the modified word's first byte (LSB) address. Address is automatically aligned to a word boundary.

Action:  $tempa \leftarrow src \text{ andnot } (0x3);$  # force alignment to word boundary

$temp \leftarrow memory\_word(tempa);$  #  $\overline{LOCK}$  asserted at  
 # beginning of memory read

$memory\_word(tempa) \leftarrow (src/dst \text{ and } mask) \text{ or } (temp \text{ and not}(mask));$   
 #  $\overline{LOCK}$  deasserted during memory write after the memory write completes  
 $src/dst \leftarrow temp;$

Faults: Type *Mismatch*. Non-supervisor reference of a *sfr* and/or non-supervisor attempt to write to internal data RAM.

Example: `atmod g5, g7, g10 # g5 ← g5 masked by g7, where g5  
 # specifies the address of a  
 # word in memory;  
 # g10 ← initial value, stored  
 # at address g5 in memory`

Opcode: **atmod** 610H REG

See Also: **atadd**

9.3.7 **b, bx**

Mnemonic:     **b**            Branch  
                  **bx**          Branch Extended

Format:       **b**            *targ*  
                                   disp  
                  **bx**          *targ*  
                                   mem

Description:    Branches to the specified target.

With the **b** instruction, IP specified with *targ* operand can be no farther than  $-2^{23}$  to  $(2^{23} - 4)$  bytes from current IP. When using the Intel i960 processor assembler, *targ* operand must be a label which specifies target instruction's IP.

**bx** performs the same operation as **b** except the target instruction can be farther than  $-2^{23}$  to  $(2^{23} - 4)$  bytes from current IP. Here, the target operand is an effective address, which allows the full range of addressing modes to be used to specify target instruction's IP. The "IP + displacement" addressing mode allows the instruction to be IP-relative. Indirect branching can be performed by placing target address in a register then using a register-indirect addressing mode.

Refer to section 3.3, "MEMORY ADDRESSING MODES" (pg. 3-5) for a complete discussion of the addressing modes.

Action:       **b:**            IP  $\leftarrow$  IP + *displacement*;     # resume execution at new IP  
                  **bx:**          IP  $\leftarrow$  *targ*;                    # resume execution at new IP

Faults:       Trace        *Instruction. Branch.*  
                                   Instruction and Branch Trace Events are signaled after instruction completion. Trace fault is generated if PC.te=1 and TC.i or TC.b=1.

Operation     *Unimplemented.* Execution from on-chip data RAM.  
                   *Operand.* Invalid operand value encountered. (**bx** only)  
                   *Opcode.* Invalid operand encoding encountered (**bx** only)

Example:      b xyz                            # IP  $\leftarrow$  xyz;  
                  bx 1332 (ip)                 # IP  $\leftarrow$  IP + 8 + 1332;  
                  # this example uses IP-relative addressing

Opcode:       **b**            08H            CTRL  
                  **bx**          84H            MEM

See Also:      **bal, balx, BRANCH IF, COMPARE AND BRANCH, bbc, bbs**



### 9.3.8 **bal, balx**

Mnemonic: **bal** Branch and Link  
**balx** Branch and Link Extended

Format: **bal** *targ*  
disp  
**balx** *targ*, *dst*  
mem reg

Description: Stores address of instruction following **bal** or **balx** in a register then branches to the instruction specified with the *targ* operand.

The **bal** and **balx** instructions are used to call leaf procedures (procedures that do not call other procedures). The IP saved in the register provides a return IP that the leaf procedure can branch to (using a **b** or **bx** instruction) to perform a return from the procedure. Note that these instructions do not use the processor’s call-and-return mechanism, so the calling procedure shares its local-register set with the called (leaf) procedure.

With **bal**, address of next instruction is stored in register g14. *targ* operand value can be no farther than  $-2^{23}$  to  $(2^{23} - 4)$  bytes from current IP. When using the Intel i960 processor assembler, *targ* must be a label which specifies the target instruction’s IP.

**balx** performs same operation as **bal** except next instruction address is stored in *dst* (allowing the return IP to be stored in any available register). With **balx**, target instruction can be farther than  $-2^{23}$  to  $(2^{23} - 4)$  bytes from current IP. Here, the target operand is a memory type, which allows full range of addressing modes to be used to specify target IP. “IP + displacement” addressing mode allows instruction to be IP-relative. Indirect branching can be performed by placing target address in a register and then using a register-indirect addressing mode.

Refer to section 3.3, “MEMORY ADDRESSING MODES” (pg. 3-5) for a complete discussion of addressing modes available with memory-type operands.

Action: **bal:** g14 ← IP + 4; # next IP destination is always g14  
IP ← IP + *displacement*; # resume execution at new IP  
**balx:** dst ← IP + inst length; # instruction length is 4 or 8 bytes  
IP ← *targ*; # resume execution at the new IP

Faults: Trace *Instruction. Branch.*  
Instruction and Branch Trace Events are signaled after instruction completion. Trace fault is generated if PC.te=1 and TC.i or TC.br=1.



Operation *Unimplemented*. Execution from on-chip data RAM.  
*Operand*. Invalid operand value encountered.  
*Opcode*. Invalid operand encoding encountered.

Example:      `bal xyz`                    # IP ← xyz;  
               `balx (g2), g4`       # IP ← (g2);  
                                       # address of return instruction  
                                       # is stored in g4;  
                                       # example of indirect addressing

Opcode:       **bal**            0BH            CTRL  
               **balx**          85H            MEM

See Also:     **b, bx, BRANCH IF, COMPARE AND BRANCH, bbc, bbs**



### 9.3.9 **bbc, bbs**

Mnemonic:     **bbc**{.t|.f}     Check Bit and Branch If Clear  
                  **bbs**{.t|.f}     Check Bit and Branch If Set

Format:       **bb**\*{.t|.f}     *bitpos*,            *src*,                *targ*  
                                   reg/lit                reg/sfr            disp

Description:     Checks bit in *src* (designated by *bitpos*) and sets AC register condition code according to *src* value. The processor then performs conditional branch to instruction specified with *targ*, based on condition code state.

Optional .t or .f suffix may be appended to mnemonic. Use .t to speed-up execution when these instructions usually take the branch; use .f to speed-up execution when these instructions usually do not take the branch. If suffix is not provided, assembler is free to provide one.

For **bbc**, if selected bit in *src* is clear, the processor sets condition code to  $000_2$  and branches to instruction specified with *targ*; otherwise, it sets condition code to  $010_2$  and goes to next instruction.

For **bbs**, if selected bit is set, the processor sets condition code to  $010_2$  and branches to *targ*; otherwise, it sets condition code to  $000_2$  and goes to next instruction.

*targ* can be no farther than  $-2^{12}$  to  $(2^{12} - 4)$  bytes from current IP. When using the Intel i960 processor assembler, *targ* must be a label which specifies target instruction's IP.

9

Action:

**bbc:**

```

if ((src and  $2^{(bitpos \bmod 32)}$ ) = 0)
    AC.cc ←  $000_2$ ;
    IP ← IP + displacement;
    # resume execution at new IP
else
    AC.cc ←  $010_2$ ;
    # resume execution at next IP

```

**bbs:**

```

if ((src and  $2^{(bitpos \bmod 32)}$ ) = 1)
    AC.cc ←  $010_2$ ;
    IP ← IP + displacement;
    # resume execution at new IP
else
    AC.cc ←  $000_2$ ;
    # resume execution at next IP

```

**INSTRUCTION SET REFERENCE**

Faults: Trace *Instruction. Branch* (if taken).  
Instruction and Branch Trace Events are signaled after instruction completion. Trace fault is generated if PC.te=1 and TC.i or TC.b=1.

Operation *Unimplemented*. Execution from on-chip data RAM.

Type *Mismatch*. Non-supervisor reference of a *sfr*.

Example: # assume bit 10 of r6 is clear  
bbc 10, r6, xyz # bit 10 of r6 is checked  
# and found clear;  
# AC.cc ← 000  
# IP ← xyz;

Opcode: **bbc** 30H COBR  
**bbs** 37H COBR

See Also: **chkbit, COMPARE AND BRANCH, BRANCH IF**





### 9.3.10 BRANCH IF

|           |                    |                            |
|-----------|--------------------|----------------------------|
| Mnemonic: | <b>be</b> {.t .f}  | Branch If Equal/True       |
|           | <b>bne</b> {.t .f} | Branch If Not Equal        |
|           | <b>bl</b> {.t .f}  | Branch If Less             |
|           | <b>ble</b> {.t .f} | Branch If Less Or Equal    |
|           | <b>bg</b> {.t .f}  | Branch If Greater          |
|           | <b>bge</b> {.t .f} | Branch If Greater Or Equal |
|           | <b>bo</b> {.t .f}  | Branch If Ordered          |
|           | <b>bno</b> {.t .f} | Branch If Unordered/False  |

Format: **b\***{.t|.f} *targ*  
disp

Description: Branches to instruction specified with *targ* operand according to AC register condition code state.

Optional .t or .f suffix may be appended to mnemonic. Use .t to speed-up execution when these instructions usually take the branch; use .f to speed-up execution when these instructions usually do not take the branch. If a suffix is not provided, assembler is free to provide one.

For all branch-if instructions except **bno**, the processor branches to instruction specified with *targ*, if the logical AND of condition code and mask-part of opcode is not zero. Otherwise, it goes to next instruction.

For **bno**, the processor branches to instruction specified with *targ* if the condition code is zero. Otherwise, it goes to next instruction.

For instance, **bno** (unordered) can be used as a branch-if false instruction when coupled with **chkbit**. For **bno**, branch is taken if condition code equals  $000_2$ . **be** can be used as branch-if true instruction.

#### NOTE:

**bo** and **bno** are used by implementations that include floating point coprocessor for branch operations involving real numbers. **bno** can be used as branch-if-false instruction when used after **chkbit**. **be** can be used as branch-if-true instruction when following **chkbit**.

The *targ* operand value can be no farther than  $-2^{23}$  to  $(2^{23} - 4)$  bytes from current IP.

The following table shows condition code mask for each instruction. The mask is in opcode bits 0-2.

| Instruction | Mask             | Condition        |
|-------------|------------------|------------------|
| bno         | 000 <sub>2</sub> | Unordered        |
| bg          | 001 <sub>2</sub> | Greater          |
| be          | 010 <sub>2</sub> | Equal            |
| bge         | 011 <sub>2</sub> | Greater or equal |
| bl          | 100 <sub>2</sub> | Less             |
| bne         | 101 <sub>2</sub> | Not equal        |
| ble         | 110 <sub>2</sub> | Less or equal    |
| bo          | 111 <sub>2</sub> | Ordered          |

Action: For all instructions except **bno**:

**if** ((mask **and** AC.cc) ≠ 000<sub>2</sub>) IP ← IP + displacement;  
# resume execution at new IP

**bno**:

**if** (AC.cc = 000<sub>2</sub>) IP ← IP + displacement;  
# resume execution at new IP  
**else** # resume execution at next IP

Faults: Trace *Instruction. Branch (if taken). Breakpoint*  
Instruction and Branch Trace Events are signaled after instruction completion. Trace fault is generated if PC.te=1 and TC.i or TC.b=1.

Operation *Unimplemented.* Execution from on-chip data RAM.

Example: # assume (AC.cc AND 100<sub>2</sub>) ≠ 0  
bl xyz # IP ← xyz;

Opcode: **be** 12H CTRL  
**bne** 15H CTRL  
**bl** 14H CTRL  
**ble** 16H CTRL  
**bg** 11H CTRL  
**bge** 13H CTRL  
**bo** 17H CTRL  
**bno** 10H CTRL

See Also: **b, bx, bbc, bbs, COMPARE AND BRANCH, bal, balx, BRANCH IF**



### 9.3.11 call

Mnemonic: **call** Call

Format: **call** *targ*  
disp

Description: Calls a new procedure. *targ* operand specifies the IP of called procedure's first instruction. When using the Intel i960 processor assembler, *targ* must be a label.

In executing this instruction, the processor performs a local call operation as described in section 5.4, "LOCAL CALLS" (pg. 5-12). As part of this operation, the processor saves the set of local registers associated with the calling procedure and allocates a new set of local registers and a new stack frame for the called procedure. Processor then goes to the instruction specified with *targ* and begins execution.

*targ* can be no farther than  $-2^{23}$  to  $(2^{23} - 4)$  bytes from current IP.

Action: wait for any uncompleted instructions to finish;  
 $temp \leftarrow (SP + 0xf \text{ andnot } (0xf));$  # round to next boundary,  
 $memory(FP) \leftarrow r0:15;$  # these accesses are cached in  
 $RIP \leftarrow next\ IP$  # local register cache  
 $PFP \leftarrow FP;$   
 $PFP.rt \leftarrow 000_2;$   
 $FP \leftarrow temp;$   
 $SP \leftarrow temp + 64;$   
 $IP \leftarrow IP + displacement;$

Faults: Trace *Instruction. Call. Breakpoint.*  
 Instruction and Call Trace Events are signaled after instruction completion. Trace fault is generated if PC.te=1 and TC.i or TC.c=1.

Operation *Unimplemented.* Execution from on-chip data RAM.

Example: `call xyz` # IP ← xyz

Opcode: **call** 09H CTRL

See Also: **bal, calls, callx**

### 9.3.12 **calls**

Mnemonic: **calls** Call System

Format: **calls** *targ*  
reg/lit

Description: Calls a system procedure. *targ* specifies called procedure's number. For **calls**, the processor performs system call operation described in section 5.5, "SYSTEM CALLS" (pg. 5-12). *targ* provides an index to a system procedure table entry from which the processor gets the called procedure's IP.

The called procedure can be a local or supervisor procedure, depending on system procedure table entry type. If it is a supervisor procedure, the processor switches to supervisor mode (if not already in this mode).

Processor also allocates a new set of local registers and new stack frame for called procedure. If the processor switches to supervisor mode, the new stack frame is created on the supervisor stack.

Action: **if** (*targ* > 259) Protection-length fault;  
wait for any uncompleted instructions to finish;  
temp\_entry ← memory\_word(SPT(*targ*));  
# SPT(*targ*) is the address of the system procedure table entry *targ*.  
RIP ← next IP;  
**if** ((temp\_entry.type = local) **or** (PC.em = supervisor))  
{  
# no stack switch required  
# round to next boundary,  
temp\_FP ← (SP + 0x10) **andnot**(0xf);  
temp\_rt ← 000<sub>2</sub>; # return type is local  
}  
**else**  
{  
# stack switch to supervisor stack  
# required; read supervisor  
temp\_FP ← memory\_word(cached(SPT));  
# stack pointer  
# set return type to supervisor  
**if** (PC.te = 0) temp\_rt ← 010<sub>2</sub>; # with trace disabled  
**else** temp\_rt ← 011<sub>2</sub>; # with trace enabled  
PC.em ← supervisor; # Trace enable bit of the supervisor  
PC.te ← temp\_FP.T; # stack pointer is written to PC.te  
}



Action: # These accesses are cached in the local register cache.  
 memory(FP) ← r0:15  
 PFP ← FP;  
 PFP.ft ← temp\_rt;  
 FP ← temp\_FP;  
 SP ← temp\_FP + 64;  
 IP ← temp\_entry **andnot** (0x3);

Faults: Trace *Instruction. Call. Supervisor. Breakpoint*  
 Instruction, Call and Supervisor Trace Events are signaled after instruction completion. Trace fault is generated if PC.te=1 and TC.i, TC.c or TC.s=1.  
 Operation *Unimplemented.* Execution from on-chip data RAM.  
 Type *Mismatch.* Non-supervisor reference of a *sfr*.  
 Protection *Length.* Specifies a system procedure number greater than 259.

Example: `calls r12` # IP ← value obtained from  
 # procedure table for procedure  
 # number given in r12

Opcode: **calls** 660H REG

See Also: **bal, call, callx**



### 9.3.13 **callx**

Mnemonic: **callx** Call Extended

Format: **callx** *targ*  
mem

Description: Calls new procedure. *targ* specifies IP of called procedure's first instruction.

In executing **callx**, the processor performs a local call as described in section 5.4, "LOCAL CALLS" (pg. 5-12). As part of this operation, the processor allocates a new set of local registers and a new stack frame for the called procedure. Processor then goes to the instruction specified with *targ* and begins execution of new procedure.

**callx** performs the same operation as call except the target instruction can be farther than  $-2^{23}$  to  $(2^{23} - 4)$  bytes from current IP.

The *targ* operand is a memory type, which allows the full range of addressing modes to be used to specify the IP of the target instruction. The "IP + displacement" addressing mode allows the instruction to be IP-relative. Indirect calls can be performed by placing the target address in a register and then using one of the register-indirect addressing modes.

Refer to CHAPTER 3, DATA TYPES AND MEMORY ADDRESSING MODES for a complete discussion of addressing modes.

Action: wait for any uncompleted instructions to finish;  
 $\text{temp} \leftarrow (\text{SP} + 0x10) \text{ andnot } (0xf); \quad \# \text{ round to next boundary}$   
 $\text{RIP} \leftarrow \text{next IP};$   
 $\text{memory}(\text{FP}) \leftarrow \text{r0:15} \quad \# \text{ these accesses are cached in}$   
 $\quad \quad \quad \quad \quad \quad \quad \quad \# \text{ local register cache}$   
 $\text{PFP} \leftarrow \text{FP};$   
 $\text{PFP.rt} \leftarrow 000_2$   
 $\text{FP} \leftarrow \text{temp};$   
 $\text{SP} \leftarrow \text{temp} + 64;$   
 $\text{IP} \leftarrow \text{targ};$

Faults: Trace *Instruction. Call.*  
 Instruction and Call Trace Events are signaled after instruction completion. Trace fault is generated if PC.te=1 and TC.i, or TC.c=1.

Operation *Unimplemented.* Execution from on-chip data RAM.

*Operand.* Invalid operand value encountered.

*Opcod.* Invalid operand encoding encountered.





### 9.3.14 **chkbit**

|              |  |  |
|--------------|--|--|
| Mnemonic:    | <b>chkbit</b>  | Check Bit  |
| Format:      | <b>chkbit</b>  | <i>bitpos</i> , <i>src</i><br>reg/lit/sfr reg/lit/sfr        |
| Description: | Checks bit in <i>src</i> designated by <i>bitpos</i> and sets condition code according to value found. If bit is set, condition code is set to 010 <sub>2</sub> ; if bit is clear, condition code is set to 000 <sub>2</sub> . |  |
| Action:      | <b>if</b> (( <i>src</i> <b>and</b> 2 <sup>(<i>bitpos</i> <b>mod</b> 32)) = 0)<br/>             AC.cc ← 000<sub>2</sub>;<br/> <b>else</b><br/>             AC.cc ← 010<sub>2</sub>;       </sup>                                |  |
| Faults:      | Type   | <i>Mismatch</i> . Non-supervisor reference of a <i>sfr</i> . |
| Example:     | <pre>chkbit 13, g8 # checks bit 13 in g8 and               # sets AC.cc according to the result</pre>  |  |
| Opcode:      | <b>chkbit</b>  | 5AEH REG   |
| See Also:    | <b>alterbit, clrbit, notbit, setbit, cmpi, cmpo</b>  |  |





### 9.3.15 **clrbt**

|              |  |  |
|--------------|--|--|
| Mnemonic:    | <b>clrbt</b>   | Clear Bit  |
| Format:      | <b>clrbt</b>   | <i>bitpos</i> , <i>src</i> , <i>dst</i><br>reg/lit/sfr reg/lit/sfr reg/sfr |
| Description: | Copies <i>src</i> value to <i>dst</i> with one bit cleared. <i>bitpos</i> operand specifies bit to be cleared. |  |
| Action:      | $dst \leftarrow src \text{ andnot}(2^{(bitpos \bmod 32)});$  |  |
| Faults:      | Type <i>Mismatch</i> . Non-supervisor reference of a <i>sfr</i> .  |  |
| Example:     | <code>clrbt 23, g3, g6 # g6 ← g3 with bit 23 cleared</code>  |  |
| Opcode:      | <b>clrbt</b>   | 58CH REG   |
| See Also:    | <b>alterbit, chkbit, notbit, setbit</b>  |  |

### 9.3.16 **cmpdeci, cmpdeco**

Mnemonic: **cmpdeci** Compare and Decrement Integer  
**cmpdeco** Compare and Decrement Ordinal

Format: **cmpdec\*** *src1*, *src2*, *dst*  
 reg/lit/sfr reg/lit/sfr reg/sfr

Description: Compares *src2* and *src1* values and sets condition code according to comparison results. *src2* is then decremented by one and result is stored in *dst*. The following table shows condition code setting for the three possible results of the comparison.

| Condition Code   | Comparison                |
|------------------|---------------------------|
| 100 <sub>2</sub> | <i>src1</i> < <i>src2</i> |
| 010 <sub>2</sub> | <i>src1</i> = <i>src2</i> |
| 001 <sub>2</sub> | <i>src1</i> > <i>src2</i> |

These instructions are intended for use in ending iterative loops. For **cmpdeci**, integer overflow is ignored to allow looping down through the minimum integer values.

Action: **if** (*src1* < *src2*) AC.cc ← 100<sub>2</sub>;  
**else if** (*src1* = *src2*) AC.cc ← 010<sub>2</sub>;  
                                   **else**  
   AC.cc ← 001<sub>2</sub>;  
*dst* ← *src2* - 1;                   #overflow suppressed for **cmpdeci** instruction

Faults: Type *Mismatch*. Non-supervisor reference of a *sfr*.

Example: `cmpdeci 12, g7, g1 # compares g7 with 12 and sets`  
                                   # AC.cc to indicate the result;  
                                   # g1 ← g7 - 1

Opcode: **cmpdeci** 5A7H REG  
**cmpdeco** 5A6H REG

See Also: **cmpinco, cmpo, cmpi, cmpinci, COMPARE AND BRANCH**



### 9.3.17 **cmpi, cmpo**

Mnemonic: **cmpi** Compare Integer  
**cmpo** Compare Ordinal

Format: **cmp\*** *src1*, *src2*  
reg/lit/sfr reg/lit/sfr

Description: Compares *src2* and *src1* values and sets condition code according to comparison results. The following table shows condition code settings for the three possible comparison results.

| Condition Code   | Comparison                |
|------------------|---------------------------|
| 100 <sub>2</sub> | <i>src1</i> < <i>src2</i> |
| 010 <sub>2</sub> | <i>src1</i> = <i>src2</i> |
| 001 <sub>2</sub> | <i>src1</i> > <i>src2</i> |

**cmpi** followed by a branch-if instruction is equivalent to a compare-integer-and-branch instruction. The latter method of comparing and branching produces more compact code; however, the former method can result in faster running code if used to take advantage of pipelining in the architecture. Same is true for **cmpo** and the compare-ordinal-and-branch instructions.

Action: **if** (*src1* < *src2*) AC.cc ← 100<sub>2</sub>;  
**else if** (*src1* = *src2*) AC.cc ← 010<sub>2</sub>;  
**else** AC.cc ← 001<sub>2</sub>;



Faults: Type *Mismatch*. Non-supervisor reference of a *sfr*.

Example: `cmpo r9, 0x10 # compares the value in r9 with 0x10`  
`# and sets AC.cc to indicate the`  
`# result`  
`bg xyz # branches to xyz if the value of r9`  
`# was greater than 0x10`

Opcode: **cmpi** 5A1H REG  
**cmpo** 5A0H REG

See Also: **COMPARE AND BRANCH, cmpdeci, cmpdeco, cmpinci, cmpinco, concmpi, concmpo**



### 9.3.18 **cmpinci, cmpinco**

Mnemonic:     **cmpinci**     Compare and Increment Integer  
                   **cmpinco**     Compare and Increment Ordinal

Format:         **cmpinc\***     *src1*,             *src2*,             *dst*  
                                   reg/lit/sfr         reg/lit/sfr         reg/sfr

Description:     Compares *src2* and *src1* values and sets condition code according to comparison results. *src2* is then incremented by one and result is stored in *dst*. The following table shows condition code settings for the three possible comparison results.

| Condition Code   | Comparison                |
|------------------|---------------------------|
| 100 <sub>2</sub> | <i>src1</i> < <i>src2</i> |
| 010 <sub>2</sub> | <i>src1</i> = <i>src2</i> |
| 001 <sub>2</sub> | <i>src1</i> > <i>src2</i> |

These instructions are intended for use in ending iterative loops. For **cmpinci**, integer overflow is ignored to allow looping up through the maximum integer values.

Action:         **if** (*src1* < *src2*) AC.cc ← 100<sub>2</sub>;  
                   **else if** (*src1* = *src2*) AC.cc ← 010<sub>2</sub>;  
   **else** AC.cc ← 001<sub>2</sub>;  
                   *dst* ← *src2* + 1;         # overflow suppressed for **cmpinci** instruction

Faults:         Type         Mismatch. Non-supervisor reference of a *sfr*.

Example:         cmpinco r8, g2, g9 # compares the values in g2  
   # and r8 and sets AC.cc to  
   # indicate the result;  
   # g9 ← g2 + 1

Opcode:         **cmpinci**     5A5H             REG  
                   **cmpinco**     5A4H             REG

See Also:       **cmpdeco, cmpo, cmpi, cmpdeci, COMPARE AND BRANCH**



## 9.3.19

## COMPARE AND BRANCH

|           |                       |  |
|-----------|-----------------------|--|
| Mnemonic: | <b>cmpibe{.t .f}</b>  | Compare Integer and Branch If Equal            |
|           | <b>cmpibne{.t .f}</b> | Compare Integer and Branch If Not Equal        |
|           | <b>cmpibl{.t .f}</b>  | Compare Integer and Branch If Less             |
|           | <b>cmpible{.t .f}</b> | Compare Integer and Branch If Less Or Equal    |
|           | <b>cmpibg{.t .f}</b>  | Compare Integer and Branch If Greater          |
|           | <b>cmpibge{.t .f}</b> | Compare Integer and Branch If Greater Or Equal |
|           | <b>cmpibo{.t .f}</b>  | Compare Integer and Branch If Ordered          |
|           | <b>cmpibno{.t .f}</b> | Compare Integer and Branch If Not Ordered      |
|           | <b>cmpobe{.t .f}</b>  | Compare Ordinal and Branch If Equal            |
|           | <b>cmpobne{.t .f}</b> | Compare Ordinal and Branch If Not Equal        |
|           | <b>cmpobl{.t .f}</b>  | Compare Ordinal and Branch If Less             |
|           | <b>cmpoble{.t .f}</b> | Compare Ordinal and Branch If Less Or Equal    |
|           | <b>cmpobg{.t .f}</b>  | Compare Ordinal and Branch If Greater          |
|           | <b>cmpobge{.t .f}</b> | Compare Ordinal and Branch If Greater Or Equal |

|         |                      |                          |                          |                     |
|---------|----------------------|--------------------------|--------------------------|---------------------|
| Format: | <b>cmpib*{.t .f}</b> | <i>src1</i> ,<br>reg/lit | <i>src2</i> ,<br>reg/sfr | <i>targ</i><br>disp |
|         | <b>cmpob*{.t .f}</b> | <i>src1</i> ,<br>reg/lit | <i>src2</i> ,<br>reg/sfr | <i>targ</i><br>disp |

Description: Compares *src2* and *src1* values and sets AC register condition code according to comparison results. If logical AND of condition code and mask part of opcode is not zero, the processor branches to instruction specified with *targ*; otherwise, the processor goes to next instruction.

Optional *.t* or *.f* suffix may be appended to mnemonic. Use *.t* to speed-up execution when these instructions usually take the branch. Use *.f* to speed-up execution when these instructions usually do not take the branch. If suffix is not provided, assembler is free to provide one.

*targ* can be no farther than  $-2^{12}$  to  $(2^{12} - 4)$  bytes from current IP. When using the Intel i960 processor assembler, *targ* must be a label which specifies target instruction's IP.

The following table shows the condition-code mask for each instruction. The mask is in bits 0-2 of the opcode.

Functions these instructions perform can be duplicated with a **cmpi** or **cmpo** followed by a branch-if instruction, as described in section 9.3.17, “cmpi, cmpo” (pg. 9-29).

| Instruction    | Mask             | Branch Condition |
|----------------|------------------|------------------|
| <b>cmpibno</b> | 000 <sub>2</sub> | No Condition     |
| <b>cmpibg</b>  | 001 <sub>2</sub> | $src1 > src2$    |
| <b>cmpibe</b>  | 010 <sub>2</sub> | $src1 = src2$    |
| <b>cmpibge</b> | 011 <sub>2</sub> | $src1 \geq src2$ |
| <b>cmpibl</b>  | 100 <sub>2</sub> | $src1 < src2$    |
| <b>cmpibne</b> | 101 <sub>2</sub> | $src1 \neq src2$ |
| <b>cmpible</b> | 110 <sub>2</sub> | $src1 \leq src2$ |
| <b>cmpibo</b>  | 111 <sub>2</sub> | Any Condition    |
| <b>cmpobg</b>  | 001 <sub>2</sub> | $src1 > src2$    |
| <b>cmpobe</b>  | 010 <sub>2</sub> | $src1 = src2$    |
| <b>cmpobge</b> | 011 <sub>2</sub> | $src1 \geq src2$ |
| <b>cmpobl</b>  | 100 <sub>2</sub> | $src1 < src2$    |
| <b>cmpobne</b> | 101 <sub>2</sub> | $src1 \neq src2$ |
| <b>cmpoble</b> | 110 <sub>2</sub> | $src1 \leq src2$ |

**NOTE:** **cmpibo** always branches; **cmpibno** never branches.

Action:       **if** ( $src1 < src2$ ) AC.cc  $\leftarrow$  100<sub>2</sub>;  
                   **else if** ( $src1 = src2$ ) AC.cc  $\leftarrow$  010<sub>2</sub>;  
                                   **else** AC.cc  $\leftarrow$  001<sub>2</sub>;  
                   **if** ( $(mask \text{ and } AC.cc) \neq 000_2$ ) IP  $\leftarrow$  IP + *displacement*;  
   # resume execution at the new IP  
                   **else** IP  $\leftarrow$  IP + 4;    # resume execution at the next IP

Faults:       Trace       *Instruction. Branch* (if taken).  
                                   Instruction and Branch Trace Events are signaled after  
                                   instruction completion. Trace fault is generated if PC.te=1 and  
                                   TC.i or TC.br=1.

Operation    *Unimplemented.* Execution from on-chip data RAM.

Type         *Mismatch.* Non-supervisor reference of a *sfr*.

Example:      # assume g3 < g9  
                   cmpibl g3, g9, xyz                    # g9 is compared with g3;  
   # IP  $\leftarrow$  xyz.  
  
                   # assume 19  $\geq$  r7  
                   cmpobge 19, r7, xyz                    # 19 is compared with r7  
   # IP  $\leftarrow$  xyz.



|         |                |     |      |
|---------|----------------|-----|------|
| Opcode: | <b>cmpibe</b>  | 3AH | COBR |
|         | <b>cmpibne</b> | 3DH | COBR |
|         | <b>cmpibl</b>  | 3CH | COBR |
|         | <b>cmpible</b> | 3EH | COBR |
|         | <b>cmpibg</b>  | 39H | COBR |
|         | <b>cmpibge</b> | 3BH | COBR |
|         | <b>cmpibo</b>  | 3FH | COBR |
|         | <b>cmpibno</b> | 38H | COBR |
|         | <b>cmpobe</b>  | 32H | COBR |
|         | <b>cmpobne</b> | 35H | COBR |
|         | <b>cmpobl</b>  | 34H | COBR |
|         | <b>cmpoble</b> | 36H | COBR |
|         | <b>cmpobg</b>  | 31H | COBR |
|         | <b>cmpobge</b> | 33H | COBR |

See Also: **BRANCH IF, cmpi, cmpo, bal, balx**

### 9.3.20 **concmpi, concmpo**

|              |  |  |
|--------------|--|--|
| Mnemonic:    | <b>concmpi</b>   | Conditional Compare Integer                                  |
|              | <b>concmpo</b>   | Conditional Compare Ordinal                                  |
| Format:      | <b>concmp*</b>   | <i>src1</i> , <i>src2</i><br>reg/lit/sfr reg/lit/sfr         |
| Description: | <p>Compares <i>src2</i> and <i>src1</i> values if condition code bit 2 is not set. If comparison is performed, condition code is set according to comparison results. Otherwise, condition codes are not altered.</p> <p>These instructions are provided to facilitate bounds checking by means of two-sided range comparisons (e.g., is A between B and C?). They are generally used after a compare instruction to test whether a value is inclusively between two other values.</p> <p>The example below illustrates this application by testing whether <i>g3</i> value is between <i>g5</i> and <i>g6</i> values, where <i>g5</i> is assumed to be less than <i>g6</i>. First a comparison (<b>cmpo</b>) of <i>g3</i> and <i>g6</i> is performed. If <i>g3</i> is less than or equal to <i>g6</i> (i.e., condition code is either 010<sub>2</sub> or 001<sub>2</sub>), a conditional comparison (<b>concmpo</b>) of <i>g3</i> and <i>g5</i> is then performed. If <i>g3</i> is greater than or equal to <i>g5</i> (indicating that <i>g3</i> is within the bounds of <i>g5</i> and <i>g6</i>), condition code is set to 010<sub>2</sub>; otherwise, it is set to 001<sub>2</sub>.</p> |  |
| Action:      | <b>if</b> (AC.cc2 = 0)<br><b>if</b> ( <i>src1</i> ≤ <i>src2</i> ) AC.cc ← 010 <sub>2</sub> ;<br><b>else</b> AC.cc ← 001 <sub>2</sub> ;   |  |
| Faults:      | Type   | <i>Mismatch</i> . Non-supervisor reference of a <i>sfr</i> . |
| Example:     | <pre> cmpo g6, g3          # compares g6 and g3 and                     # sets AC.cc concmpo g5, g3       # if AC.cc2 ≠ 1,                     # g5 is compared with g3 </pre>   |  |
| Opcode:      | <b>concmpi</b>   | 5A3H REG   |
|              | <b>concmpo</b>   | 5A2H REG   |
| See Also:    | <b>cmpo, cmpi, cmpdeci, cmpdeco, cmpinci, cmpinco, COMPARE AND BRANCH</b>  |  |





### 9.3.21 **divi, divo**

|              |   |   |                              |                       |
|--------------|---|---|------------------------------|-----------------------|
| Mnemonic:    | <b>divi</b>   | Divide Integer  |                              |                       |
|              | <b>divo</b>   | Divide Ordinal  |                              |                       |
| Format:      | <b>div*</b>   | <i>src1</i> ,<br>reg/lit/sfr  | <i>src2</i> ,<br>reg/lit/sfr | <i>dst</i><br>reg/sfr |
| Description: | Divides <i>src2</i> value by <i>src1</i> value and stores the result in <i>dst</i> . Remainder is discarded.  |   |                              |                       |
|              | For <b>divi</b> , an integer-overflow fault can be signaled.  |   |                              |                       |
| Action:      | <i>dst</i> ← quotient( <i>src2</i> / <i>src1</i> );<br># <i>src2</i> , <i>src1</i> and <i>dst</i> are 32-bits |   |                              |                       |
| Faults:      | Type  | <i>Mismatch</i> . Non-supervisor reference of a <i>sfr</i> .  |                              |                       |
|              | Arithmetic  | <i>Zero Divide</i> . The <i>src1</i> operand is 0.<br><i>Integer Overflow</i> . Result too large for destination register ( <b>divi</b> only). If overflow occurs and AC.om=1, fault is suppressed and AC.of is set to 1. Result's least significant 32-bits are stored in <i>dst</i> . |                              |                       |
| Example:     | divo r3, r8, r13 # r13 ← r8/r3  |   |                              |                       |
| Opcode:      | <b>divi</b>   | 74BH  | REG                          |                       |
|              | <b>divo</b>   | 70BH  | REG                          |                       |
| See Also:    | <b>ediv, mulo, muli, emul</b>   |   |                              |                       |



### 9.3.22 **ediv**

|              |   |  |                              |                       |
|--------------|---|--|------------------------------|-----------------------|
| Mnemonic:    | <b>ediv</b>   | Extended Divide  |                              |                       |
| Format:      | <b>ediv</b>   | <i>src1</i> ,<br>reg/lit/sfr                                 | <i>src2</i> ,<br>reg/lit/sfr | <i>dst</i><br>reg/sfr |
| Description: | <p>Divides <i>src2</i> by <i>src1</i> and stores result in <i>dst</i>. The <i>src2</i> value is a long ordinal (64 bits) contained in two adjacent registers. <i>src2</i> specifies the lower numbered register which contains operand's least significant bits. <i>src2</i> must be an even numbered register (i.e., r0, r2, r4, ... or g0, g2, ... or sf0, sf2, ...). <i>src1</i> value is a normal ordinal (i.e., 32 bits).</p> <p>The result consists of a one-word remainder and a one-word quotient. Remainder is stored in the register designated by <i>dst</i>; quotient is stored in the next highest numbered register. <i>dst</i> must be an even numbered register (i.e., r0, r2, r4, ... or g0, g2, ... or sf0, sf2, ...).</p> <p>This instruction performs ordinal arithmetic.</p> <p>If this operation overflows (quotient or remainder do not fit in 32 bits), no fault is raised and the result is undefined.</p> |  |                              |                       |
| Action:      | $dst \leftarrow (src2 - (src2 / src1) * src1); \quad \# \text{ remainder}$ $dst + 1 \leftarrow (src2 / src1); \quad \# \text{ quotient}$ <p># <i>src2</i> is 64-bits; <i>src1</i>, <i>dst</i> and <i>dst+1</i> are 32-bits</p>  |  |                              |                       |
| Faults:      | Type  | <i>Mismatch</i> . Non-supervisor reference of a <i>sfr</i> . |                              |                       |
|              | Arithmetic  | <i>Zero Divide</i> . The <i>src1</i> operand is 0.           |                              |                       |
| Example:     | <pre>ediv g3, g4, g10 # g10 ← remainder of g4,g5/g3                 # g11 ← quotient of g4,g5/g3</pre>  |  |                              |                       |
| Opcode:      | <b>ediv</b>   | 671H   | REG                          |                       |
| See Also:    | <b>emul, divi, divo</b>   |  |                              |                       |



### 9.3.23 **emul**

Mnemonic: **emul** Extended Multiply

Format: **emul** *src1*, *src2*, *dst*  
 reg/lit/sfr reg/lit/sfr reg/sfr

Description: Multiplies *src2* by *src1* and stores the result in *dst*. Result is a long ordinal (64 bits) stored in two adjacent registers. *dst* specifies lower numbered register, which receives the result's least significant bits. *dst* must be an even numbered register (i.e., r0, r2, r4, ... or g0, g2, ... or sf0, sf2, ...).

This instruction performs ordinal arithmetic.

Action:  $dst \leftarrow src2 * src1;$  # *src1* and *src2* are 32-bits; *dst* is 64-bits.

Faults: Type *Mismatch*. Non-supervisor reference of a *sfr*.

Example: `emul r4, r5, g2 # g2, g3 ← r4 * r5`

Opcode: **emul** 670H REG

See Also: **ediv, muli, mulo**

## 9.3.24

**eshro****(80960Cx Processor Only)**

|              |  |  |                              |                       |
|--------------|--|--|------------------------------|-----------------------|
| Mnemonic:    | <b>eshro</b>   | Extended Shift Right Ordinal                                 |                              |                       |
| Format:      | <b>eshro</b>   | <i>src1</i> ,<br>reg/lit/sfr                                 | <i>src2</i> ,<br>reg/lit/sfr | <i>dst</i><br>reg/sfr |
| Description: | <p>Shifts <i>src2</i> right by (<i>src1</i> <b>mod</b> 32) places and stores the result in <i>dst</i>. Bits shifted beyond the least-significant bit are discarded.</p> <p><i>src2</i> value is a long ordinal (i.e., 64 bits) contained in two adjacent registers. <i>src2</i> operand specifies the lower numbered register, which contains operand's least significant bits. <i>src2</i> operand must be an even numbered register (i.e., r0, r2, r4, ... or g0, g2, ... or sf0, sf2, ...).</p> <p><i>src1</i> operand is a single 32-bit register, literal, or sfr, where the lower 5-bits specify the number of places that the <i>src2</i> operand is to be shifted.</p> <p>The shift operation result's least significant 32 bits are stored in <i>dst</i>.</p> |  |                              |                       |
| Action:      | $dst \leftarrow src2 \gg (src1 \bmod 32);$<br># <i>src2</i> is 64 bits, <i>src1</i> and <i>dst</i> are 32 bits   |  |                              |                       |
| Faults:      | Type   | <i>Mismatch</i> . Non-supervisor reference of a <i>sfr</i> . |                              |                       |
| Example:     | <pre>eshro g3, g4, g11 # g11 ← g4,5 shifted right by                   # (g3 MOD 32)</pre>   |  |                              |                       |
| Opcode:      | <b>eshro</b>   | 5D8H   | REG                          |                       |
| See Also:    | <b>SHIFT, extract</b>  |  |                              |                       |



### 9.3.25 **extract**

|              |   |  |                             |                       |
|--------------|---|--|-----------------------------|-----------------------|
| Mnemonic:    | <b>extract</b>  | Extract  |                             |                       |
| Format:      | <b>extract</b>  | <i>bitpos</i> ,<br>reg/lit/sfr                               | <i>len</i> ,<br>reg/lit/sfr | <i>src/dst</i><br>reg |
| Description: | Shifts a specified bit field in <i>src/dst</i> right and zero fills bits to left of shifted bit field. <i>bitpos</i> value specifies the least significant bit of the bit field to be shifted; <i>len</i> value specifies bit field length. |  |                             |                       |
| Action:      | $src/dst \leftarrow (src/dst \gg (bitpos \bmod 32)) \text{ and } (2^{len} - 1)$ ;   |  |                             |                       |
| Faults:      | Type  | <i>Mismatch</i> . Non-supervisor reference of a <i>sfr</i> . |                             |                       |
| Example:     | <code>extract 5, 12, g4</code>  | # g4 ← g4 with bits 5 through<br># 16 shifted right          |                             |                       |
| Opcode:      | <b>extract</b>  | 651H   | REG                         |                       |
| See Also:    | <b>modify</b>   |  |                             |                       |

### 9.3.26 FAULT IF

Mnemonic:        **faulte**{.t|.f}    Fault If Equal  
                   **faultne**{.t|.f}    Fault If Not Equal  
                   **faultl**{.t|.f}        Fault If Less  
                   **faultle**{.t|.f}        Fault If Less Or Equal  
                   **faultg**{.t|.f}        Fault If Greater  
                   **faultge**{.t|.f}        Fault If Greater Or Equal  
                   **faulto**{.t|.f}        Fault If Ordered  
                   **faultno**{.t|.f}        Fault If Not Ordered

Format:            **fault\***{.t|.f}

Description:        Raises a constraint-range fault if the logical AND of the condition code and opcode's mask-part is not zero. For **faultno** (unordered), fault is raised if condition code is equal to 000<sub>2</sub>.

Optional **.t** or **.f** suffix may be appended to the mnemonic. Use **.t** to speed-up execution when these instructions usually fault; use **.f** to speed-up execution when these instructions usually do not fault. If a suffix is not provided, the assembler is free to provide one.

**faulto** and **faultno** are provided for use by implementations with a floating point coprocessor. They are used for compare and branch (or fault) operations involving real numbers.

The following table shows the condition-code mask for each instruction. The mask is opcode bits 0-2.

| Instruction | Mask             | Condition        |
|-------------|------------------|------------------|
| faultno     | 000 <sub>2</sub> | Unordered        |
| faultg      | 001 <sub>2</sub> | Greater          |
| faulte      | 010 <sub>2</sub> | Equal            |
| faultge     | 011 <sub>2</sub> | Greater or equal |
| faultl      | 100 <sub>2</sub> | Less             |
| faultne     | 101 <sub>2</sub> | Not equal        |
| faultle     | 110 <sub>2</sub> | Less or equal    |
| faulto      | 111 <sub>2</sub> | Ordered          |

Action:            For all instructions except **faultno**:  
     **if** ((mask **and** AC.cc) ≠ 000<sub>2</sub>) Constraint-range fault;

**faultno**:  
     **if** (AC.cc=000<sub>2</sub>) Constraint-range fault;

Faults:            Constraint    *Range*. If condition being tested is true.



Example:           # assume (AC.cc AND 110<sub>2</sub>) 000<sub>2</sub>  
                  faultle           # Constraint Range Fault is generated

|         |                |     |      |
|---------|----------------|-----|------|
| Opcode: | <b>faulte</b>  | 1AH | CTRL |
|         | <b>faultne</b> | 1DH | CTRL |
|         | <b>faultl</b>  | 1CH | CTRL |
|         | <b>faultle</b> | 1EH | CTRL |
|         | <b>faultg</b>  | 19H | CTRL |
|         | <b>faultge</b> | 1BH | CTRL |
|         | <b>faulto</b>  | 1FH | CTRL |
|         | <b>faultno</b> | 18H | CTRL |

See Also:       **BRANCH IF, TEST**

### 9.3.27 **flushreg**

Mnemonic: **flushreg** Flush Local Registers

Format: **flushreg**

Description: Copies the contents of every cached register set—except the current set—to its associated stack frame in memory. The entire register cache is then marked as purged (or invalid). On a return to a stack frame for which the local registers are not cached, the processor reloads the locals from memory.

**flushreg** is provided to allow a debugger or application program to circumvent the processor's normal call/return mechanism. For example, a debugger may need to go back several frames in the stack on the next return, rather than using the normal return mechanism that returns one frame at a time. Since the local registers of an unknown number of previous stack frames may be cached, a **flushreg** must be executed prior to modifying the PFP to return to a frame other than the one directly below the current frame.

Action: Write all cached local register sets — except the current set — to memory; Invalidate the local register cache.

Faults: Type *Mismatch*. Non-supervisor attempt to write to internal data RAM.

Example: `flushreg`

Opcode: **flushreg** 66D REG





### 9.3.28 fmark

Mnemonic: **fmark** Force Mark

Format: **fmark**

Description: Generates a breakpoint trace event. Causes a breakpoint trace event to be generated, regardless of breakpoint trace mode flag setting, providing the PC register trace enable bit (bit 0) is set.

When a breakpoint trace event is detected, the PC register trace-fault-pending flag (bit 10) and the TC register breakpoint-trace-event flag (bit 23) are set. Then, a breakpoint-trace fault is generated before the next instruction executes.

For more information on trace fault generation, refer to CHAPTER 7, FAULTS.

Action: **if** (PC.te=1)  
                                   PC.tfp ← 1;  
                                   TC.bte ← 1;  
                                   Trace Breakpoint trace fault

Faults: Trace *Instruction. Breakpoint.*  
 Instruction and Breakpoint Trace Events are signaled after instruction completion. Trace fault is generated if PC.te=1.

Operation *Unimplemented.* Execution from on-chip data RAM.

Example: 

```
ld xyz, r4
addi r4, r5, r6
fmark
# Breakpoint trace event is generated at
# this point in the instruction stream.
```

Opcode: **fmark** 66CH REG

See Also: **mark**

### 9.3.29 LOAD

|              |  |  |                   |
|--------------|--|--|-------------------|
| Mnemonic:    | <b>ld</b>  | Load   |                   |
|              | <b>ldob</b>  | Load Ordinal Byte  |                   |
|              | <b>ldos</b>  | Load Ordinal Short   |                   |
|              | <b>ldib</b>  | Load Integer Byte  |                   |
|              | <b>ldis</b>  | Load Integer Short   |                   |
|              | <b>ldl</b>   | Load Long  |                   |
|              | <b>ldt</b>   | Load Triple  |                   |
|              | <b>ldq</b>   | Load Quad  |                   |
| Format:      | <b>ld*</b>   | <i>src</i> ,<br>mem  | <i>dst</i><br>reg |
| Description: | <p>Copies byte or byte string from memory into a register or group of successive registers.</p> <p><i>The src operand specifies the address of first byte to be loaded. The full range of addressing modes may be used in specifying src. Refer to section 3.3, “MEMORY ADDRESSING MODES” (pg. 3-5).</i></p> <p><i>dst specifies a register or the first (lowest numbered) register of successive registers.</i></p> <p><b>ldob</b> and <b>ldib</b> load a byte and <b>ldos</b> and <b>ldis</b> load a half word and convert it to a full 32-bit word. Data being loaded is sign-extended during integer loads and zero-extended during ordinal loads.</p> <p><b>ld</b>, <b>ldl</b>, <b>ldt</b> and <b>ldq</b> instructions copy 4, 8, 12 and 16 bytes, respectively, from memory into successive registers.</p> <p>For <b>ldl</b>, <b>dst</b> must specify an even numbered register (e.g., g0, g2, ... or r0, r2,...). For <b>ldt</b> and <b>ldq</b>, <i>dst</i> must specify a register number that is a multiple of four (e.g., g0, g4, g8, ... or r0, r4, r8, ...). Results are unpredictable if registers are not aligned on the required boundary or if data extends beyond register g15 or r15 for <b>ldl</b>, <b>ldt</b> or <b>ldq</b>.</p> |  |                   |
| Action:      | <b>ld:</b>   | <i>dst</i> ← memory_word ( <i>src</i> );                           |                   |
|              | <b>ldob:</b>   | <i>dst</i> ← memory_byte ( <i>src</i> ) zero-extended to 32 bits;  |                   |
|              | <b>ldos:</b>   | <i>dst</i> ← memory_short ( <i>src</i> ) zero-extended to 32 bits; |                   |
|              | <b>ldib:</b>   | <i>dst</i> ← memory_byte ( <i>src</i> ) sign-extended to 32 bits;  |                   |
|              | <b>ldis:</b>   | <i>dst</i> ← memory_short ( <i>src</i> ) sign-extended to 32 bits; |                   |
|              | <b>ldl:</b>  | <i>dst</i> ← memory_long ( <i>src</i> );                           |                   |
|              | <b>ldt:</b>  | <i>dst</i> ← memory_triple ( <i>src</i> );                         |                   |
|              | <b>ldq:</b>  | <i>dst</i> ← memory_quad ( <i>src</i> );                           |                   |





### 9.3.30 **lda**

Mnemonic:     **lda**           Load Address

Format:       **lda**           *src*,            *dst*  
                                   mem            reg  
                                   *efa*

Description:    Computes the effective address specified with *src* and stores it in *dst*. The *src* address is not checked for validity. Any addressing mode may be used to calculate *efa*.

An important application of this instruction is to load a constant longer than 5 bits into a register. (To load a register with a constant of 5 bits or less, **mov** can be used with a literal as the *src* operand.)

Action:        *dst* ← *efa* (*src*);

Faults:        *Operation*    *Operand*. Invalid operand value encountered.  
                                   *Opcode*. Invalid opcode encoding encountered.

Example:        lda 58 (g9), g1    # g1 ← g9+58  
                   lda 0x749, r8    # r8 ← 0x749

Opcode:        **lda**           8CH            MEM



### 9.3.31 **mark**

Mnemonic: **mark** Mark

Format: **mark**

Description: Generates breakpoint trace event if breakpoint trace mode is enabled. Breakpoint trace mode is enabled if the PC register trace enable bit (bit 0) and the TC register breakpoint trace mode bit (bit 7) are set.

When a breakpoint trace event is detected, the PC register trace-fault-pending flag (bit 10) and the TC register breakpoint-trace-event flag (bit 23) are set. Then, before the next instruction is executed, a breakpoint trace fault is generated.

If breakpoint trace mode is not enabled, **mark** behaves like a no-op.

For more information on trace fault generation, refer to CHAPTER 8, TRACING AND DEBUGGING.

Action: **if** ((PC.te=1) **and** (TC.br=1))  
           PC.tfp ← 1;  
           TC.bte ← 1;  
           Trace Breakpoint trace fault;

Faults: Trace *Instruction. Breakpoint* (if enabled).  
 Instruction and Breakpoint Trace Events are signaled after instruction completion. Trace fault is generated if PC.te=1 and TC.i or TC.br=1.

Operation *Unimplemented.* Execution from on-chip data RAM.

Example: 

```
# Assume that the breakpoint trace mode is enabled.
ld xyz, r4
addi r4, r5, r6
mark
# Breakpoint trace event is generated at this point
# in the instruction stream.
```

Opcode: **mark** 66BH REG

See Also: **fmark, modpc, modtc**



**9.3.32 modac**

|              |  |  |                             |                       |
|--------------|--|--|-----------------------------|-----------------------|
| Mnemonic:    | <b>modac</b>   | Modify AC  |                             |                       |
| Format:      | <b>modac</b>   | <i>mask</i> ,<br>reg/lit/sfr                                 | <i>src</i> ,<br>reg/lit/sfr | <i>dst</i><br>reg/sfr |
| Description: | Reads and modifies the AC register. <i>src</i> contains the value to be placed in the AC register; <i>mask</i> specifies bits that may be changed. Only bits set in <i>mask</i> are modified. Once the AC register is changed, its initial state is copied into <i>dst</i> . |  |                             |                       |
| Action:      | temp ← AC<br>AC ← ( <i>src</i> <b>and</b> <i>mask</i> ) or (AC <b>andnot</b> <i>mask</i> );<br><i>dst</i> ← temp;  |  |                             |                       |
| Faults:      | Type   | <i>Mismatch</i> . Non-supervisor reference of a <i>sfr</i> . |                             |                       |
| Example:     | <pre>modac g1, g9, g12 # AC ← g9, masked by g1                   # g12 ← initial value of AC</pre>   |  |                             |                       |
| Opcode:      | <b>modac</b>   | 645H   | REG                         |                       |
| See Also:    | <b>modpc, modtc</b>  |  |                             |                       |



### 9.3.33 **modi**

|              |   |  |                              |                       |
|--------------|---|--|------------------------------|-----------------------|
| Mnemonic:    | <b>modi</b>   | Modulo Integer   |                              |                       |
| Format:      | <b>modi</b>   | <i>src1</i> ,<br>reg/lit/sfr                                 | <i>src2</i> ,<br>reg/lit/sfr | <i>dst</i><br>reg/sfr |
| Description: | Divides <i>src2</i> by <i>src1</i> , where both are integers and stores the modulo remainder of the result in <i>dst</i> . If the result is nonzero, <i>dst</i> has the same sign as <i>src1</i> .  |  |                              |                       |
| Action:      | <b>if</b> ( <i>src1</i> = 0) Arithmetic Zero Divide fault;<br>$dst \leftarrow src2 - ((src2/src1) * src1)$ ;<br><b>if</b> (( <i>src2</i> * <i>src1</i> < 0) <b>and</b> ( <i>dst</i> ≠ 0)) $dst \leftarrow dst + src1$ ;<br># <i>src1</i> , <i>src2</i> and <i>dst</i> are 32 bits |  |                              |                       |
| Faults:      | Type  | <i>Mismatch</i> . Non-supervisor reference of a <i>sfr</i> . |                              |                       |
|              | Arithmetic  | <i>Zero Divide</i> . The <i>src1</i> operand is 0.           |                              |                       |
| Example:     | <code>modi r9, r2, r5 # r5 ← modulo (r2/r9)</code>  |  |                              |                       |
| Opcode:      | <b>modi</b>   | 749H   | REG                          |                       |
| See Also:    | <b>divi, divo, remi, remo</b>   |  |                              |                       |

### 9.3.34 **modify**

|              |   |  |                             |                       |
|--------------|---|--|-----------------------------|-----------------------|
| Mnemonic:    | <b>modify</b>   | Modify   |                             |                       |
| Format:      | <b>modify</b>   | <i>mask</i> ,<br>reg/lit/sfr                                 | <i>src</i> ,<br>reg/lit/sfr | <i>src/dst</i><br>reg |
| Description: | Modifies selected bits in <i>src/dst</i> with bits from <i>src</i> . The <i>mask</i> operand selects the bits to be modified: only bits set in the <i>mask</i> operand are modified in <i>src/dst</i> . |  |                             |                       |
| Action:      | $src/dst \leftarrow (src \text{ and } mask) \text{ or } (src/dst \text{ andnot } mask);$  |  |                             |                       |
| Faults:      | Type  | <i>Mismatch</i> . Non-supervisor reference of a <i>sfr</i> . |                             |                       |
| Example:     | <code>modify g8, g10, r4 # r4 ← g10 masked by g8</code>   |  |                             |                       |
| Opcode:      | <b>modify</b>   | 650H   | REG                         |                       |
| See Also:    | <b>alterbit, extract</b>  |  |                             |                       |





### 9.3.35 **modpc**

|              |  |  |                              |                       |
|--------------|--|--|------------------------------|-----------------------|
| Mnemonic:    | <b>modpc</b>   | Modify Process Controls  |                              |                       |
| Format:      | <b>modpc</b>   | <i>src</i> ,<br>reg/lit/sfr  | <i>mask</i> ,<br>reg/lit/sfr | <i>src/dst</i><br>reg |
| Description: | <p>Reads and modifies the PC register as specified with <i>mask</i> and <i>src/dst</i>. <i>src/dst</i> operand contains the value to be placed in the PC register; <i>mask</i> operand specifies bits that may be changed. Only bits set in the <i>mask</i> are modified. Once the PC register is changed, its initial value is copied into <i>src/dst</i>. The <i>src</i> operand is a dummy operand that should specify a literal or the same register as the <i>mask</i> operand.</p> <p>The processor must be in supervisor mode to use this instruction with a non-zero <i>mask</i> value. If <i>mask</i>=0, this instruction can be used to read the process controls, without the processor being in supervisor mode.</p> <p>If the action of this instruction results in processor priority being lowered, the interrupt table is checked for pending interrupts.</p> <p>Changing the PC register reserved fields can lead to unpredictable behavior as described in section 2.6.3, “Process Controls (PC) Register” (pg. 2-17).</p> |  |                              |                       |
| Action:      | <p><b>if</b> (<i>mask</i> ≠ 0)</p> <p style="padding-left: 2em;"><b>if</b> (PC.em ≠ supervisor) Type-mismatch fault;<br/>temp ← PC;<br/>PC ← (<i>mask and src/dst</i>) <b>or</b> (PC <b>andnot</b> <i>mask</i>);<br/><i>src/dst</i> ← temp;<br/><b>if</b> (temp.p &gt; PC.p) check_pending_interrupts;</p> <p><b>else</b> <i>src/dst</i> ← PC;</p>   |  |                              |                       |
| Faults:      | Type   | <p><i>Mismatch</i>. Non-supervisor reference of a <i>sfr</i>.</p> <p><i>Mismatch</i>. Attempted to execute instruction with non-zero <i>mask</i> value while not in supervisor mode.</p> |                              |                       |
| Example:     | <pre>modpc g9, g9, g8 # process controls ← g8                 # masked by g9</pre>   |  |                              |                       |
| Opcode:      | <b>modpc</b>   | 655H   | REG                          |                       |
| See Also:    | <b>modac, modtc</b>  |  |                              |                       |

When a modify-process-controls (**modpc**) instruction causes a program’s priority to be lowered, other i960 processor family members check for pending interrupts in the memory-based interrupt table; the i960 Cx devices internally store the priority of the highest pending interrupt found in the interrupt table’s pending interrupts field. To improve performance, the stored priority is checked — rather than the memory-based interrupt table — when **modpc** changes a process priority. The internal priority value is updated each time an interrupt is posted using **sysctl**.



**9.3.36 modtc**

Mnemonic: **modtc** Modify Trace Controls

Format: **modtc** *mask*, *src*, *dst*  
 reg/lit/sfr reg/lit/sfr reg/sfr

Description: Reads and modifies TC register as specified with *mask* and *src*. The *src* operand contains the value to be placed in the TC register; *mask* operand specifies bits that may be changed. Only bits set in *mask* are modified. *mask* must not enable modification of reserved bits. Once the TC register is changed, its initial state is copied into *dst*.

The changed trace controls may take effect immediately or may be delayed. If delayed, the changed trace controls may not take effect until after the first non-branching instruction is fetched from memory or after four non-branching instructions are executed.

For more information on the trace controls, refer to CHAPTER 7, FAULTS and CHAPTER 8, TRACING AND DEBUGGING.

Action:  $\text{temp} \leftarrow \text{TC};$   
 $\text{mask} \leftarrow \text{TC};$   
 $\text{TC} \leftarrow (\text{mask} \text{ and } \text{src}) \text{ or } (\text{temp} \text{ andnot } \text{mask});$   
 $\text{dst} \leftarrow \text{temp};$

Faults: Type *Mismatch*. Non-supervisor reference of a *sfr*.

Example: `modtc g12, g10, g2 # trace controls ← g10 masked`  
`# by g12; previous trace`  
`# controls stored in g2`

Opcode: **modtc** 654H REG

See Also: **modac, modpc**



### 9.3.37 MOVE

Mnemonic:       **mov**           Move  
                   **movl**       Move Long  
                   **movt**       Move Triple  
                   **movq**       Move Quad

Format:           **mov\***       *src*,            *dst*  
                                   reg/lit/sfr        reg/sfr

Description:      Copies the contents of one or more source registers (specified with *src*) to one or more destination registers (specified with *dst*).

For **movl**, **movt** and **movq**, *src* and *dst* specify the first (lowest numbered) register of several successive registers. *src* and *dst* registers must be even numbered (e.g., g0, g2, ... or r0, r2, ... or sf0, sf2, ...) for **movl** and an integral multiple of four (e.g., g0, g4, ... or r0, r4, ... or sf0, sf4, ...) for **movt** and **movq**.

The moved register values are unpredictable when: 1) the *src* and *dst* operands overlap; 2) registers are not properly aligned.

Action:           *dst* ← *src*;

Faults:           Type           *Mismatch*. Non-supervisor reference of a *sfr*.

Example:          movt g8, r4           # r4, r5, r6 ← g8, g9, g10

Opcode:           **mov**           5CCH           REG  
                   **movl**       5DCH           REG  
                   **movt**       5ECH           REG  
                   **movq**       5FCH           REG

See Also:         **LOAD, STORE, lda**

### 9.3.38 **mul**, **mulo**

|              |  |   |
|--------------|--|---|
| Mnemonic:    | <b>mul</b>   | Multiply Integer  |
|              | <b>mulo</b>  | Multiply Ordinal  |
| Format:      | <b>mul*</b>  | <i>src1</i> , <i>src2</i> , <i>dst</i><br>reg/lit/sfr reg/lit/sfr reg/sfr   |
| Description: | Multiplies the <i>src2</i> value by the <i>src1</i> value and stores the result in <i>dst</i> . The binary results from these two instructions are identical. The only difference is that <b>mul</b> can signal an integer overflow. |   |
| Action:      | $dst \leftarrow src2 * src1;$<br># <i>src1</i> , <i>src2</i> and <i>dst</i> are 32 bits  |   |
| Faults:      | Type   | <i>Mismatch</i> . Non-supervisor reference of a <i>sfr</i> .  |
|              | Arithmetic   | <i>Integer Overflow</i> . Result is too large for destination register ( <b>mul</b> only). If overflow occurs and AC.om=1, the fault is suppressed and AC.of is set to 1. Result's least significant 32 bits are stored in <i>dst</i> . |
| Example:     | mul r3, r4, r9 # r9 ← r4 TIMES r3  |   |
| Opcode:      | <b>mul</b>   | 741H REG  |
|              | <b>mulo</b>  | 701H REG  |
| See Also:    | <b>emul</b> , <b>ediv</b> , <b>divi</b> , <b>ddiv</b>  |   |



### 9.3.39 **nand**

|              |   |  |                              |                       |
|--------------|---|--|------------------------------|-----------------------|
| Mnemonic:    | <b>nand</b>   | Nand   |                              |                       |
| Format:      | <b>nand</b>   | <i>src1</i> ,<br>reg/lit/sfr                                 | <i>src2</i> ,<br>reg/lit/sfr | <i>dst</i><br>reg/sfr |
| Description: | Performs a bitwise NAND operation on <i>src2</i> and <i>src1</i> values and stores the result in <i>dst</i> . |  |                              |                       |
| Action:      | $dst \leftarrow \mathbf{not} (src2 \mathbf{and} src1);$   |  |                              |                       |
| Faults:      | Type  | <i>Mismatch</i> . Non-supervisor reference of a <i>sfr</i> . |                              |                       |
| Example:     | <code>nand g5, r3, r7 # r7 ← r3 NAND g5</code>  |  |                              |                       |
| Opcode:      | <b>nand</b>   | 58EH   | REG                          |                       |
| See Also:    | <b>and, andnot, nor, not, notand, notor, or, ornot, xnor, xor</b>   |  |                              |                       |

**9.3.40 nor**

|              |  |  |                              |                       |
|--------------|--|--|------------------------------|-----------------------|
| Mnemonic:    | <b>nor</b>   | Nor  |                              |                       |
| Format:      | <b>nor</b>   | <i>src1</i> ,<br>reg/lit/sfr                         | <i>src2</i> ,<br>reg/lit/sfr | <i>dst</i><br>reg/sfr |
| Description: | Performs a bitwise NOR operation on the <i>src2</i> and <i>src1</i> values and stores the result in <i>dst</i> . |  |                              |                       |
| Action:      | $dst \leftarrow \mathbf{not} (src2 \mathbf{or} src1);$   |  |                              |                       |
| Faults:      | Type   | <i>Mismatch</i> . Non-supervisor reference of a sfr. |                              |                       |
| Example:     | <code>nor g8, 28, r5 # r5 ← 28 NOR g8</code>   |  |                              |                       |
| Opcode:      | <b>nor</b>   | 588H   | REG                          |                       |
| See Also:    | <b>and, andnot, nand, not, notand, notor, or, ornot, xnor, xor</b>   |  |                              |                       |



### 9.3.41 not, notand

|              |  |  |                              |                       |
|--------------|--|--|------------------------------|-----------------------|
| Mnemonic:    | <b>not</b>   | Not  |                              |                       |
|              | <b>notand</b>  | Not And  |                              |                       |
| Format:      | <b>not</b>   | <i>src</i> ,<br>reg/lit/sfr                            | <i>dst</i><br>reg/sfr        |                       |
|              | <b>notand</b>  | <i>src1</i> ,<br>reg/lit/sfr                           | <i>src2</i> ,<br>reg/lit/sfr | <i>dst</i><br>reg/sfr |
| Description: | Performs a bitwise NOT ( <b>not</b> instruction) or NOT AND ( <b>notand</b> instruction) operation on the <i>src2</i> and <i>src1</i> values and stores the result in <i>dst</i> . |  |                              |                       |
| Action:      | <b>not:</b>  | $dst \leftarrow \text{not}(src);$                      |                              |                       |
|              | <b>notand:</b>   | $dst \leftarrow (\text{not}(src2)) \text{ and } src1;$ |                              |                       |
| Faults:      | Type   | <i>Mismatch</i> . Non-supervisor reference of a sfr.   |                              |                       |
| Action:      | not g2, g4   | # g4 ← NOT g2  |                              |                       |
|              | notand r5, r6, r7  | # r7 ← NOT r6 AND r5                                   |                              |                       |
| Opcode:      | <b>not</b>   | 58AH   | REG                          |                       |
|              | <b>notand</b>  | 584H   | REG                          |                       |
| See Also:    | <b>and, andnot, nand, nor, notor, or, ornot, xnor, xor</b>   |  |                              |                       |

### 9.3.42 notbit

|              |  |  |                             |                       |
|--------------|--|--|-----------------------------|-----------------------|
| Mnemonic:    | <b>notbit</b>  | Not Bit  |                             |                       |
| Format:      | <b>notbit</b>  | <i>bitpos</i> ,<br>reg/lit/sfr                       | <i>src</i> ,<br>reg/lit/sfr | <i>dst</i><br>reg/sfr |
| Description: | Copies the <i>src</i> value to <i>dst</i> with one bit toggled. The <i>bitpos</i> operand specifies the bit to be toggled. |  |                             |                       |
| Action:      | $dst \leftarrow src \mathbf{xor} 2^{(bitpos \bmod 32)}$ ;  |  |                             |                       |
| Faults:      | Type   | <i>Mismatch</i> . Non-supervisor reference of a sfr. |                             |                       |
| Example:     | notbit r3, r12, r7 # r7 ← r12 with the bit<br># specified in r3 toggled  |  |                             |                       |
| Opcode:      | <b>notbit</b>  | 580H   | REG                         |                       |
| See Also:    | <b>alterbit, chkbit, clrbit, setbit</b>  |  |                             |                       |





### 9.3.43 notor

|              |  |  |                              |                       |
|--------------|--|--|------------------------------|-----------------------|
| Mnemonic:    | <b>notor</b>   | Not Or   |                              |                       |
| Format:      | <b>notor</b>   | <i>src1</i> ,<br>reg/lit/sfr                                 | <i>src2</i> ,<br>reg/lit/sfr | <i>dst</i><br>reg/sfr |
| Description: | Performs a bitwise NOTOR operation on <i>src2</i> and <i>src1</i> values and stores result in <i>dst</i> . |  |                              |                       |
| Action:      | $dst \leftarrow (\text{not}(src2)) \text{ or } src1;$  |  |                              |                       |
| Faults:      | Type   | <i>Mismatch</i> . Non-supervisor reference of a <i>sfr</i> . |                              |                       |
| Example:     | <code>notor g12, g3, g6</code> # $g6 \leftarrow \text{NOT } g3 \text{ OR } g12$                            |  |                              |                       |
| Opcode:      | <b>notor</b>   | 58DH   | REG                          |                       |
| See Also:    | <b>and, andnot, nand, nor, not, notand, or, ornot, xnor, xor</b>   |  |                              |                       |

### 9.3.44 or, ornot

|              |   |   |                              |                       |
|--------------|---|---|------------------------------|-----------------------|
| Mnemonic:    | <b>or</b>   | Or  |                              |                       |
|              | <b>ornot</b>  | Or Not  |                              |                       |
| Format:      | <b>or</b>   | <i>src1</i> ,<br>reg/lit/sfr                            | <i>src2</i> ,<br>reg/lit/sfr | <i>dst</i><br>reg/sfr |
|              | <b>ornot</b>  | <i>src1</i> ,<br>reg/lit/sfr                            | <i>src2</i> ,<br>reg/lit/sfr | <i>dst</i><br>reg/sfr |
| Description: | Performs a bitwise OR ( <b>or</b> instruction) or ORNOT ( <b>ornot</b> instruction) operation on the <i>src2</i> and <i>src1</i> values and stores the result in <i>dst</i> . |   |                              |                       |
| Action:      | <b>or:</b>  | $dst \leftarrow src2 \text{ or } src1;$                 |                              |                       |
|              | <b>ornot:</b>   | $dst \leftarrow src2 \text{ or } (\text{not } (src1));$ |                              |                       |
| Faults:      | Type  | <i>Mismatch</i> . Non-supervisor reference of a sfr.    |                              |                       |
| Example:     | <code>or 14, g9, g3</code>  | # $g3 \leftarrow g9 \text{ OR } 14$                     |                              |                       |
|              | <code>ornot r3, r8, r11</code>  | # $r11 \leftarrow r8 \text{ OR NOT } r3$                |                              |                       |
| Opcode:      | <b>or</b>   | 587H  | REG                          |                       |
|              | <b>ornot</b>  | 58BH  | REG                          |                       |
| See Also:    | <b>and, andnot, nand, nor, not, notand, notor, xnor, xor</b>  |   |                              |                       |



### 9.3.45 remi, remo

|              |   |   |                              |                       |
|--------------|---|---|------------------------------|-----------------------|
| Mnemonic:    | <b>remi</b>   | Remainder Integer   |                              |                       |
|              | <b>remo</b>   | Remainder Ordinal   |                              |                       |
| Format:      | <b>rem*</b>   | <i>src1</i> ,<br>reg/lit/sfr  | <i>src2</i> ,<br>reg/lit/sfr | <i>dst</i><br>reg/sfr |
| Description: | Divides <i>src2</i> by <i>src1</i> and stores the remainder in <i>dst</i> . The sign of the result (if nonzero) is the same as the sign of <i>src2</i> .  |   |                              |                       |
| Action:      | <b>if</b> ( <i>src1</i> =0) Arithmetic Zero Divide fault;<br><i>dst</i> ← <i>src2</i> - (( <i>src2</i> / <i>src1</i> ) * <i>src1</i> );<br># <i>src1</i> , <i>src2</i> and <i>dst</i> are 32 bits |   |                              |                       |
| Faults:      | Type  | <i>Mismatch</i> . Non-supervisor reference of a <i>sfr</i> .  |                              |                       |
|              | Arithmetic  | <i>Zero Divide</i> . The <i>src1</i> operand is 0   |                              |                       |
|              |   | <i>Integer Overflow</i> . Result is too large for destination register ( <b>remi</b> only). If overflow occurs and AC.om=1, the fault is suppressed and AC.of is set to 1. The least significant 32 bits of the result are stored in <i>dst</i> . |                              |                       |
| Example:     | remo r4, r5, r6 # r6 ← r5 rem r4  |   |                              |                       |
| Opcode:      | <b>remi</b>   | 748H  | REG                          |                       |
|              | <b>remo</b>   | 708H  | REG                          |                       |
| See Also:    | <b>modi</b>   |   |                              |                       |



**9.3.46 ret**Mnemonic: **ret** ReturnFormat: **ret**

Description: Returns program control to the calling procedure. The current stack frame (i.e., that of the called procedure) is deallocated and the FP is changed to point to the calling procedure's stack frame. Instruction execution is continued at the instruction pointed to by the RIP in the calling procedure's stack frame, which is the instruction immediately following the call instruction.

As shown in the action statement below, the return-status field and prereturn-trace flag determine the action that the processor takes on the return. These fields are contained in bits 0 through 3 of register r0 of the called procedure's local registers.

Refer to section 5.2.3, "Call and Return Action" (pg. 5-5) for discussion of **ret**.

Faults: wait for any uncompleted instructions to finish;

**case** return\_type **is**

**if** ((PFP.rt=001<sub>2</sub>) **or** (PFP.rt=111<sub>2</sub>))

{ # return from fault or interrupt handler

AC ← memory(FP - 12);

**if** (PC.em=supervisor) PC ← memory(FP - 16);

}

**else if** ((PFP.rt=010<sub>2</sub>) **or** (PFP.rt=011<sub>2</sub>))

{ # return to non-supervisor procedure

PC.te ← PFP.rt0;

PC.em ← user;

}

**else if** (PFP.rt=000<sub>2</sub>)

{ # return from local

}

**else** Operation Unimplemented fault;

FP ← PFP;

# these accesses are cached in the local register cache

r0:15 ← memory(FP);

IP ← RIP;

*TraceInstruction. Return. Pre-Return.*

Instruction, Return and Pre-Return Trace Events are signaled after instruction completion. Trace fault is generated if PC.te=1 and TC.i or TC.r or TC.p=1.

Operation *Unimplemented.* Execution from on-chip data RAM.

*Unimplemented.* Reserved return type encountered.

Example: `ret           # program control returns to context of  
                  # calling procedure`

Opcode:       **ret**       0AH           CTRL

See Also:     **call, calls, callx**



### 9.3.47 rotate

Mnemonic: **rotate** Rotate

Format: **rotate** *len*, *src*, *dst*  
reg/lit/sfr reg/lit/sfr reg/sfr

Description: Copies *src* to *dst* and rotates the bits in the resulting *dst* operand to the left (toward higher significance). (Bits shifted off left end of word are inserted at right end of word.) The *len* operand specifies number of bits that the *dst* operand is rotated.

This instruction can also be used to rotate bits to the right. Here, the number of bits the word is to be rotated right is subtracted from 32 to get the *len* operand.

Faults: Type *Mismatch*. Non-supervisor reference of a sfr.

Example: rotate 13, r8, r12 # r12 ← r8 with bits rotated  
# 13 bits to left

Opcode: **rotate** 59DH REG

See Also: **SHIFT, eshro**



### 9.3.48 scanbit

Mnemonic: **scanbit** Scan For Bit

Format: **scanbit** *src*, *dst*  
 reg/lit/sfr reg/sfr

Description: Searches *src* value for most-significant set bit (1 bit). If a most significant 1 bit is found, its bit number is stored in *dst* and condition code is set to 010<sub>2</sub>. If *src* value is zero, all 1's are stored in *dst* and condition code is set to 000<sub>2</sub>.

Action:

```

tempSrc ← src;
if (tempSrc=0)
    dst ← 0xFFFFFFFF;
    AC.cc ← 0002;
else
    i ← 31;
    while ((tempSrc and 2i)=0)
        i ← i - 1;
    dst ← i;
    AC.cc ← 0102;
  
```

Faults: Type *Mismatch*. Non-supervisor reference of a sfr.

Example:

```

# assume g8 is nonzero
scanbit g8, g10 # g10 ← bit number of most-
                # significant set bit in g8;
                # AC.cc ← 0102
  
```



Opcode: **scanbit** 641H REG

See Also: **spanbit, setbit**



### 9.3.49 scanbyte

|              |   |  |
|--------------|---|--|
| Mnemonic:    | <b>scanbyte</b>   | Scan Byte Equal  |
| Format:      | <b>scanbyte</b>   | <i>src1</i> , <i>src2</i><br>reg/lit/sfr reg/lit/sfr         |
| Description: | Performs byte-by-byte comparison of <i>src1</i> and <i>src2</i> and sets condition code to 010 <sub>2</sub> if any two corresponding bytes are equal. If no corresponding bytes are equal, condition code is set to 000 <sub>2</sub> .  |  |
| Action:      | <pre> tmprc1 ← <i>src1</i>; tmprc2 ← <i>src2</i>; <b>if</b>    ((tmprc1 <b>and</b> 000000FFH) = (tmprc2 <b>and</b> 000000FFH)) <b>or</b>         (tmprc1 <b>and</b> 0000FF00H) = (tmprc2 <b>and</b> 0000FF00H) <b>or</b>         (tmprc1 <b>and</b> 00FF0000H) = (tmprc2 <b>and</b> 00FF0000H) <b>or</b>         (tmprc1 <b>and</b> FF000000H) = (tmprc2 <b>and</b> FF000000H)     AC.cc ← 010<sub>2</sub>; <b>else</b>     AC.cc ← 000<sub>2</sub>; </pre> |  |
| Faults:      | Type  | <i>Mismatch</i> . Non-supervisor reference of a <i>sfr</i> . |
| Example:     | <pre> # assume r9 = 0x11AB1100 scanbyte 0x00AB0011, r9    # AC.cc ← 010<sub>2</sub> </pre>  |  |
| Opcode:      | <b>scanbyte</b>   | 5ACH REG   |





**9.3.50** **sdma** (80960Cx Processor Only)

Mnemonic: **sdma** Setup DMA Channel

Format: **sdma** *src1*, *src2*, *src3*  
 reg/lit/sfr reg/lit/sfr reg/lit

Description: The DMA channel specified by *src1* is set up using the control word in *src2*. Dedicated data RAM for the specified DMA channel is written with *src3* value. First two bits of *src1* specify channel; *src2* specifies DMA control word as a literal or single 32-bit register; *src3* specifies a single 32-bit register if channel is data-chaining. This register contains the address of the first chaining descriptor in memory. *src3* must specify a register with a register number divisible by four.

If channel is not data chaining, *src3* specifies a triple word contained in registers *src3*, *src3+1* and *src3+2*. *src3* contains byte count for DMA; *src3+1* contains source address; *src3+2* contains destination address.

Action: `dma_control_for_channel[src1 mod 4] ← src2;`  
**if** (not chaining mode)  
     `dma_ram[src1 mod 4] ← src3; # triple-word store`  
**else**      `dma_ram[src1 mod 4] ← src3; # word store`  
`start_dma_channel[src1 mod 4];`

Faults: Constraint *Privileged*. Attempt to execute while not in supervisor mode.

Example:

```
ldconst 3, r6; # set channel
ldconst Channel_3_Modes, r7; # load controls
ldq Channel_3_transfer, r8; # load pointers
sdma r6, r7, r8 # and byte count
# from memory
# configure dma
# channel 3
```

Opcode: **sdma** 630H REG

See Also: **udma**



### 9.3.51 **setbit**

|              |  |  |                             |                       |
|--------------|--|--|-----------------------------|-----------------------|
| Mnemonic:    | <b>setbit</b>  | Set Bit  |                             |                       |
| Format:      | <b>setbit</b>  | <i>bitpos</i> ,<br>reg/lit/sfr                               | <i>src</i> ,<br>reg/lit/sfr | <i>dst</i><br>reg/sfr |
| Description: | Copies <i>src</i> value to <i>dst</i> with one bit set. <i>bitpos</i> specifies bit to be set. |  |                             |                       |
| Action:      | $dst \leftarrow src \text{ or } 2^{(bitpos \bmod 32)}$ ;                                       |  |                             |                       |
| Faults:      | Type   | <i>Mismatch</i> . Non-supervisor reference of a <i>sfr</i> . |                             |                       |
| Example:     | <code>setbit 15, r9, r1 # r1 ← r9 with bit 15 set</code>                                       |  |                             |                       |
| Opcode:      | <b>setbit</b>  | 583H   | REG                         |                       |
| See Also:    | <b>alterbit, chkbit, clrbit, notbit</b>  |  |                             |                       |



9.3.52 **SHIFT**

|           |              |                              |
|-----------|--------------|------------------------------|
| Mnemonic: | <b>shlo</b>  | Shift Left Ordinal           |
|           | <b>shro</b>  | Shift Right Ordinal          |
|           | <b>shli</b>  | Shift Left Integer           |
|           | <b>shri</b>  | Shift Right Integer          |
|           | <b>shrdi</b> | Shift Right Dividing Integer |

|         |            |              |              |            |
|---------|------------|--------------|--------------|------------|
| Format: | <b>sh*</b> | <i>len</i> , | <i>src</i> , | <i>dst</i> |
|         |            | reg/lit/sfr  | reg/lit/sfr  | reg/sfr    |

Description: Shifts *src* left or right by the number of bits indicated with the *len* operand and stores the result in *dst*. Bits shifted beyond register boundary are discarded. For values of *len* greater than 32, the processor interprets the value as 32.

**shlo** shifts zeros in from the least significant bit; **shro** shifts zeros in from the most significant bit. These instructions are equivalent to **mulo** and **divo** by the power of 2, respectively.

**shli** shifts zeros in from the least significant bit. An overflow fault is generated if the bits shifted out are not the same as the most significant bit (bit 31). If overflow occurs, *dst* will equal *src* shifted left as much as possible without overflowing.

**shri** performs a conventional arithmetic shift-right operation by shifting in the most significant bit (bit 31). When this instruction is used to divide a negative integer operand by the power of 2, it produces an incorrect quotient (discarding the bits shifted out has the effect of rounding the result toward negative).

**shrdi** is provided for dividing integers by the power of 2. With this instruction, 1 is added to the result if the bits shifted out are non-zero and the *src* operand was negative, which produces the correct result for negative operands.

**shli** and **shrdi** are equivalent to **mul** and **div** by the power of 2.

**eshro** is provided for extracting a 32-bit value from a long ordinal (i.e., 64 bits), which is contained in two adjacent registers.

|         |              |   |
|---------|--------------|---|
| Action: | <b>shlo:</b> | <b>if</b> ( <i>len</i> < 32) <i>dst</i> ← <i>src</i> << <i>len</i> ;<br><b>else</b> <i>dst</i> ← 0; |
|         | <b>shro:</b> | <b>if</b> ( <i>len</i> < 32) <i>dst</i> ← <i>src</i> >> <i>len</i> ;<br><b>else</b> <i>dst</i> ← 0; |

```

shli:    if (len > 32) i ← 32;
           else i ← len;
           temp ← src;
           s_sign ← temp.bit31
           while ((temp.bit31 = s_sign) and (i ≠ 0))
           {
           temp ← temp << 1;
           i ← i - 1;
           }
           dst ← temp;

shri:    if (len > 32) i ← 32;
           else i ← len;
           temp ← src;
           while (i ≠ 0)
           {
           temp ← temp >> 1;           # shift temp right one bit
           temp.bit31 ← temp.bit30;    # extend temp's sign bit
           i ← i - 1;
           }
           dst ← temp;

shrdi:  i ← len;
           if (i > 32) i ← 32;
           temp ← src;
           s_sign ← temp.bit31
           lost_bit ← 0;
           while (i ≠ 0)
           {
           lost_bit ← lost_bit or temp.bit0;
           temp ← temp >> 1;           # shift temp right one bit
           temp.bit31 ← temp.bit30;    # extend temp's sign bit
           i ← i - 1;
           }
           if ((s_sign = 1) and (lost_bit = 1)) temp ← temp + 1;
           dst ← temp;

```

Faults:      Type      *Mismatch*. Non-supervisor reference of a *sfr*.

Arithmetic      *Integer Overflow*. Result is too large for the destination register (**shli** only). If overflow occurs and AC.om is a 1, the fault is suppressed and AC.of is set to a 1. After an overflow, *dst* will equal *src* shifted left as much as possible without overflowing.

Example:      `shli 13, g4, r6    # g6 ← g4 shifted left 13 bits`



|         |              |      |     |
|---------|--------------|------|-----|
| Opcode: | <b>shlo</b>  | 59CH | REG |
|         | <b>shro</b>  | 598H | REG |
|         | <b>shli</b>  | 59EH | REG |
|         | <b>shri</b>  | 59BH | REG |
|         | <b>shrqi</b> | 59AH | REG |

See Also: **divi, muli, rotate, eshro**

### 9.3.53 **spanbit**

|              |   |  |
|--------------|---|--|
| Mnemonic:    | <b>spanbit</b>  | Span Over Bit  |
| Format:      | <b>spanbit</b>  | <i>src</i> , <i>dst</i><br>reg/lit/sfr reg/sfr               |
| Description: | Searches <i>src</i> value for the most significant clear bit (0 bit). If a most significant 0 bit is found, its bit number is stored in <i>dst</i> and condition code is set to 010 <sub>2</sub> . If <i>src</i> value is all 1's, all 1's are stored in <i>dst</i> and condition code is set to 000 <sub>2</sub> . |  |
| Action:      | <pre> <b>if</b> (<i>src</i> = FFFFFFFFH)     <i>dst</i> ← FFFFFFFFH;     AC.cc ← 000<sub>2</sub>; <b>else</b>     <i>i</i> ← 31;     <b>while</b> ((<i>src</i> <b>and</b> 2<sup><i>i</i></sup>) ≠ 0)         <i>i</i> ← <i>i</i> - 1;         <i>dst</i> ← <i>i</i>;         AC.cc ← 010<sub>2</sub>; </pre>        |  |
| Faults:      | Type  | <i>Mismatch</i> . Non-supervisor reference of a <i>sfr</i> . |
| Example:     | <pre> # assume r2 is not 0xffffffff spanbit r2, r9    # r9 ← bit number of most-                   # significant clear bit in r2;                   # AC.cc ← 010<sub>2</sub> </pre>  |  |
| Opcode:      | <b>spanbit</b>  | 640H REG   |
| See Also:    | <b>scanbit</b>  |  |



## 9.3.54 STORE

|           |             |                     |
|-----------|-------------|---------------------|
| Mnemonic: | <b>st</b>   | Store               |
|           | <b>stob</b> | Store Ordinal Byte  |
|           | <b>stos</b> | Store Ordinal Short |
|           | <b>stib</b> | Store Integer Byte  |
|           | <b>stis</b> | Store Integer Short |
|           | <b>stl</b>  | Store Long          |
|           | <b>stt</b>  | Store Triple        |
|           | <b>stq</b>  | Store Quad          |

|         |            |              |            |
|---------|------------|--------------|------------|
| Format: | <b>st*</b> | <i>src</i> , | <i>dst</i> |
|         |            | reg          | mem        |

**Description:** Copies a byte or group of bytes from a register or group of registers to memory. *src* specifies a register or the first (lowest numbered) register of successive registers.

*dst* specifies the address of the memory location where the byte or first byte or a group of bytes is to be stored. The full range of addressing modes may be used in specifying *dst*. Refer to section 3.3, “MEMORY ADDRESSING MODES” (pg. 3-5) for a complete discussion.

**stob** and **stib** store a byte and **stos** and **stis** store a half word from the *src* register’s low order bytes. Data for ordinal stores is truncated to fit the destination width. If the data for integer stores cannot be represented correctly in the destination width, an Arithmetic Integer Overflow fault is signaled.

**st**, **stl**, **stt** and **stq** copy 4, 8, 12 and 16 bytes, respectively, from successive registers to memory.

For **stl**, *src* must specify an even numbered register (e.g., g0, g2, ... or r0, r2, ...). For **stt** and **stq**, *src* must specify a register number that is a multiple of four (e.g., g0, g4, g8, ... or r0, r4, r8, ...).

|         |              |  |
|---------|--------------|--|
| Action: | <b>st:</b>   | memory_word ( <i>dst</i> ) ← <i>src</i> ;                      |
|         | <b>stob:</b> | memory_byte ( <i>dst</i> ) ← <i>src</i> truncated to 8 bits;   |
|         | <b>stib:</b> | memory_byte ( <i>dst</i> ) ← <i>src</i> truncated to 8 bits;   |
|         | <b>stos:</b> | memory_short ( <i>dst</i> ) ← <i>src</i> truncated to 16 bits; |
|         | <b>stis:</b> | memory_short ( <i>dst</i> ) ← <i>src</i> truncated to 16 bits; |
|         | <b>stl:</b>  | memory_long ( <i>dst</i> ) ← <i>src</i> ;                      |
|         | <b>stt:</b>  | memory_triple ( <i>dst</i> ) ← <i>src</i> ;                    |
|         | <b>stq:</b>  | memory_quad ( <i>dst</i> ) ← <i>src</i> ;                      |

**Faults:** Operation *Unaligned*. An unaligned *dst* was referenced and bit 30 of the Fault Configuration Word is 0.

*Invalid Operand*. Invalid operand value encountered.

*Opcode.* Invalid opcode encoding encountered.

Arithmetic *Integer Overflow.* Result is too large for destination (**stib** and **stis** only). If overflow occurs and AC.om=1, the fault is suppressed and AC.of is set to 1. After an overflow, destination contains the least significant n bits of the store, where n is the transfer width (8 or 16 bits).

Type *Mismatch.* Non-supervisor attempt to write to internal data RAM.

Example: `st g2, 1254 (g6) # word beginning at offset  
#1254 + (g6) ← g2`

|         |             |     |     |
|---------|-------------|-----|-----|
| Opcode: | <b>st</b>   | 92H | MEM |
|         | <b>stob</b> | 82H | MEM |
|         | <b>stos</b> | 8AH | MEM |
|         | <b>stib</b> | C2H | MEM |
|         | <b>stis</b> | CAH | MEM |
|         | <b>stl</b>  | 9AH | MEM |
|         | <b>stt</b>  | A2H | MEM |
|         | <b>stq</b>  | B2H | MEM |

See Also: **LOAD, MOVE**





### 9.3.55 **subc**

Mnemonic: **subc** Subtract Ordinal With Carry

Format: **subc** *src1*, *src2*, *dst*  
 reg/lit/sfr reg/lit/sfr reg/sfr

Description: Subtracts *src1* from *src2*, then subtracts **not** (AC.cc1) and stores the result in *dst*. If the ordinal subtraction results in a carry, AC.cc1 is set to 1, otherwise AC.cc1 is set to 0.

This instruction can also be used for integer subtraction. Here, if integer subtraction results in an overflow, condition code bit 0 is set.

**subc** does not distinguish between ordinals and integers: it sets condition code bits 0 and 1 regardless of data type.

Action:  $dst \leftarrow src2 - src1 + AC.cc1$ ;  
 $AC.cc \leftarrow 0CV_2$ ;  
 # V is 1 if integer subtraction would have generated an overflow,  
 # 0 otherwise  
 # C is Carry out of the ordinal addition of *src2* to **not** (*src1*) and  
 # carry in.

Faults: Type *Mismatch*. Non-supervisor reference of a sfr.

Example: `subc g5, g6, g7 # g7 ← g6 - g5 - not(Carry Bit)`

Opcode: **subc** 5B2H REG

See Also: **addc, addi, addo, subi, subo**

### 9.3.56 **subi, subo**

|              |  |  |
|--------------|--|--|
| Mnemonic:    | <b>subi</b>  | Subtract Integer   |
|              | <b>subo</b>  | Subtract Ordinal   |
| Format:      | <b>sub*</b>  | <i>src1</i> , <i>src2</i> , <i>dst</i><br>reg/lit/sfr reg/lit/sfr reg/sfr  |
| Description: | Subtracts <i>src1</i> from <i>src2</i> and stores the result in <i>dst</i> . The binary results from these two instructions are identical. The only difference is that <b>subi</b> can signal an integer overflow. |  |
| Action:      | $dst \leftarrow src2 - src1;$  |  |
| Faults:      | Type   | <i>Mismatch</i> . Non-supervisor reference of a sfr.   |
|              | Arithmetic   | <i>Integer Overflow</i> . Result too large for destination register ( <b>subi</b> only). Result's least significant 32 bits are stored in <i>dst</i> . If overflow occurs and AC.om=1, the fault is suppressed and AC.of is set to a 1. The least significant 32 bits of the result are stored in <i>dst</i> . |
| Example:     | subi g6, g9, g12 # g12 ← g9 - g6   |  |
| Opcode:      | <b>subi</b>  | 593H REG   |
|              | <b>subo</b>  | 592H REG   |
| See Also:    | <b>addi, addo, subc, addc</b>  |  |



**9.3.57 syncf**

Mnemonic: **syncf** Synchronize Faults

Format: **syncf**

Description: Waits for all faults to be generated that are associated with any prior uncompleted instructions.

Action: **if** (AC.nif  $\neq$  1)  
wait until no imprecise faults can occur associated with instructions which have begun, but are not completed.;

Faults:

Example: 

```
ld xyz, g6
addi r6, r8, r8
syncf
and g6, 0xFFFF, g8
# the syncf instruction ensures that any faults
# that may occur during the execution of the
# ld and addi instructions occur before the
# and instruction is executed
```

Opcode: **syncf** 66FH REG

See Also: **mark, fmark**

**INSTRUCTION SET REFERENCE**

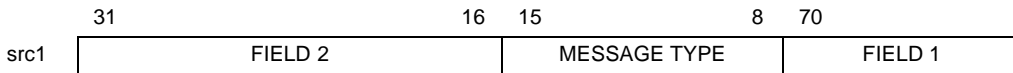
**9.3.58 sysctl (80960Cx Processor Only)**

Mnemonic: **sysctl** System Control

Format: **sysctl** *src1*, *src2*, *src3*;  
 reg/lit/sfr reg/lit/sfr reg/lit  
*message, type*

Description: Processor control function specified by the message field of *src1* is executed. The type field of *src1* is interpreted depending upon the command. Remaining *src1* bits are reserved. The *src2* and *src3* operands are also interpreted depending upon the command.

The *src1* operand is interpreted as follows:



The following table lists i960 Cx processor commands.

| Message               | <i>Src1</i> |                                      |            | <i>Src2</i>        | <i>Src3</i>  |
|-----------------------|-------------|--------------------------------------|------------|--------------------|--------------|
|                       | Type        | Field 1                              | Field 2    | Field 3            | Field 4      |
| Request Interrupt     | 00H         | Vector Number                        | N/U        | N/U                | N/U          |
| Invalidate Cache      | 01H         | N/U                                  | N/U        | N/U                | N/U          |
| Configure Cache       | 02H         | Cache Mode Configuration (see table) | N/U<br>N/U | Cache load address | N/U          |
| Reinitialize          | 03H         | N/U                                  | N/U        | 1st Inst. address  | PRCB address |
| Load Control Register | 04H         | Register Group Number                | N/U        | N/U                | N/U          |

**NOTE:** Sources and fields which are not used (designated N/U) are ignored.

When executing a **sysctl** instruction to load and lock either half or all of the cache, it is necessary to provide a cache load address. The last two bits of the cache load address must be 10<sub>2</sub> for the cache locking mechanism to work properly.



**Table 9-5. Cache Configuration Modes**

| Mode Field       | Mode Description   | CA        | CF       |
|------------------|--|-----------|----------|
| 000 <sub>2</sub> | normal cache enabled   | 1 Kbyte   | 4 Kbytes |
| XX1 <sub>2</sub> | full cache disabled  | 1 Kbyte   | 4 Kbytes |
| 100 <sub>2</sub> | Load and lock full cache (execute off-chip)                        | 1 Kbyte   | 4 Kbytes |
| 110 <sub>2</sub> | Load and lock half the cache;<br>remainder is normal cache enabled | 512 bytes | 2 Kbytes |
| 010 <sub>2</sub> | Reserved   | 1 Kbyte   | 4 Kbytes |

```

Action:      temp ← src1;
             tmpmessage ← (temp and 0xf0) >> 8;
             switch (tmpmessage)
             case 0:      # Signal an Interrupt
                       post_interrupt(temp and 0xf);
                       break;

             case 1:      # Invalidate the Instruction Cache
                       invalidate_instruction_cache;
                       break;

             case 2:      # Configure Instruction Cache
                       tmptype ← (src1 and 0xff);
                       if (tmptype.bit0 = 1) disable_instruction_cache;
                       else if (tmptype = 0x0) enable_1k_instruction_cache;
                       else if (tmptype = 0x4)
                       {
                           # Load and freeze 1k cache
                           instr_cache ← memory_1k(src2); # load 1k bytes
                           freeze_1k_instruction_cache;
                       }
                       else if (tmptype = 0 x 6)
                       {
                           # Load and freeze 512 bytes of cache
                           instr_cache ← memory_512(src2) # load 512 bytes
                           freeze_512_instruction_cache;
                       }
                       else      Reserved;
                       break;

```





```

case 3:      # Software Reset
               temp ← src2;
               load PRCB pointed to by src3;
               IP ← temp;
               break;

case 4:      # Load One Group of Control Registers
               # from the Control Table
               temp [0-3] ← memory_quad (Control Table Base + group
               offset);
               for (i ← 0; i ≤ 3; i ← i+1) control_reg[i] ← temp[i];
               break

default:    Operation invalid-operand fault;
    
```

Faults: *Unimplemented.* Attempted to execute unimplemented command.

```

Example:      ldconst Clear_cache, g6      # set clear cache message
               sysctl r6,r7,r8             # execute cache invalidation
               # r7, r8 are dummies here
               be uploaded_code           # branch to code which was
               # uploaded
    
```

Opcode: **sysctl**      659H                  REG

**NOTE:**

When a modify-process-controls (**modpc**) instruction causes a program’s priority to be lowered, other i960 processor family members check for pending interrupts in the memory-based interrupt table; the i960 Cx device internally stores the priority of the highest pending interrupt found in the interrupt table’s pending interrupts field. To improve performance, the stored priority is checked — rather than the memory-based interrupt table — when **modpc** changes a process priority. The internal priority value is updated each time an interrupt is posted using **sysctl**.



### 9.3.59 TEST

Mnemonic: **teste**{.t|.f} Test For Equal  
**testne**{.t|.f} Test For Not Equal  
**testl**{.t|.f} Test For Less  
**testle**{.t|.f} Test For Less Or Equal  
**testg**{.t|.f} Test For Greater  
**testge**{.t|.f} Test For Greater Or Equal  
**testo**{.t|.f} Test For Ordered  
**testno**{.t|.f} Test For Not Ordered

Format: **test**\*{.t|.f} *dst*  
reg/sfr

Description: Stores a true (01H) in *dst* if the logical AND of the condition code and opcode mask-part is not zero. Otherwise, the instruction stores a false (00H) in *dst*. For **testno** (Unordered), a true is stored if the condition code is 000<sub>2</sub>, otherwise a false is stored.

The following table shows the condition-code mask for each instruction. The mask is in bits 0-2 of the opcode.

| Instruction | Mask             | Condition        |
|-------------|------------------|------------------|
| testno      | 000 <sub>2</sub> | Unordered        |
| testg       | 001 <sub>2</sub> | Greater          |
| teste       | 010 <sub>2</sub> | Equal            |
| testge      | 011 <sub>2</sub> | Greater or equal |
| testl       | 100 <sub>2</sub> | Less             |
| testne      | 101 <sub>2</sub> | Not equal        |
| testle      | 110 <sub>2</sub> | Less or equal    |
| testo       | 111 <sub>2</sub> | Ordered          |

9

The optional .t or .f suffix may be appended to the mnemonic. Use .t to speed-up execution when these instructions usually store a true (1) condition in *dst*. Use .f to speed-up execution when these instructions usually store a false (0) condition in *dst*. If a suffix is not provided, the assembler is free to provide one.

Action: For all instructions except **testno**:  
**if** ((*mask* and AC.cc) = 000<sub>2</sub>) *dst* ← 0x1;  
**else** *dst* ← 0x0;  
**testno**:  
**if** (AC.cc = 000<sub>2</sub>) *dst* ← 0x1;  
**else** *dst* ← 0x0;

Faults: Type *Mismatch*. Non-supervisor reference of a *sfr*.

## INSTRUCTION SET REFERENCE

Example:           # assume AC.cc = 100<sub>2</sub>  
          testl g9       # g9 ← 0x00000001

|         |               |     |      |
|---------|---------------|-----|------|
| Opcode: | <b>teste</b>  | 22H | COBR |
|         | <b>testne</b> | 25H | COBR |
|         | <b>testl</b>  | 24H | COBR |
|         | <b>testle</b> | 26H | COBR |
|         | <b>testg</b>  | 21H | COBR |
|         | <b>testge</b> | 23H | COBR |
|         | <b>testo</b>  | 27H | COBR |
|         | <b>testno</b> | 20H | COBR |

See Also:       **cmpi, cmpdeci, cmpinci**





## 9.3.60

**udma**

(80960Cx Processor Only)

Mnemonic: **udma** Update DMA-Channel RAMFormat: **udma**

Description: The current status of the DMA channels is written to the dedicated DMA RAM.

Action: **for** (i = 0 to 3) dma\_ram[i] ← dma\_status\_channel[i];Example: 

```
udma                                # update status to dma ram
ldq Channel_3_ram,r4               # read current pointers
                                   # and byte count for dma
                                   # channel 3
```

Opcode: **udma** 631H REGSee Also: **sdma**

### 9.3.61 **xnor, xor**

|              |   |   |
|--------------|---|---|
| Mnemonic:    | <b>xnor</b>   | Exclusive Nor   |
|              | <b>xor</b>  | Exclusive Or  |
| Format:      | <b>xnor</b>   | <i>src1</i> , <i>src2</i> , <i>dst</i><br>reg/lit/sfr reg/lit/sfr reg/sfr |
|              | <b>xor</b>  | <i>src1</i> , <i>src2</i> , <i>dst</i><br>reg/lit/sfr reg/lit/sfr reg/sfr |
| Description: | Performs a bitwise XNOR ( <b>xnor</b> instruction) or XOR ( <b>xor</b> instruction) operation on the <i>src2</i> and <i>src1</i> values and stores the result in <i>dst</i> . |   |
| Action:      | <b>xnor:</b>  | $dst \leftarrow \text{not}(src2 \text{ xor } src1);$                      |
|              | <b>xor:</b>   | $dst \leftarrow src2 \text{ xor } src1;$                                  |
| Faults:      | Type  | <i>Mismatch</i> . Non-supervisor reference of a sfr.                      |
| Example:     | <code>xnor r3, r9, r12 # r12 ← r9 XNOR r3</code><br><code>xor g1, g7, g4 # g4 ← g7 XOR g1</code>  |   |
| Opcode:      | <b>xnor</b>   | 589H REG  |
|              | <b>xor</b>  | 586H REG  |
| See Also:    | <b>and, andnot, nand, nor, not, notand, notor, or, ornot</b>  |   |





# 10

## THE BUS CONTROLLER





## CHAPTER 10

# THE BUS CONTROLLER

This chapter serves as a guide for a software developer when configuring the bus controller. It overviews bus controller capabilities and implementation and describes how to program the bus controller. System designers should reference CHAPTER 11, EXTERNAL BUS DESCRIPTION for a functional description of the bus controller.

### 10.1 OVERVIEW

The bus controller supports a synchronous, 32-bit wide, demultiplexed external bus which consists of 30 address lines, four byte enables, 32 data lines, two clock outputs and control and status signals. The bus controller manages instruction fetches, data loads/stores and DMA transfer requests. Bus management is accomplished by queuing bus requests; this effectively decouples instruction execution speed from external memory access time.

Load and store instructions — the program's interface to the bus controller — work on ordinal (unsigned) or integer (signed) data. A single load or store instruction can move from 1 to 16 bytes of data. The bus controller also handles instruction fetches, which read either 8 bytes (two words) or 16 bytes (four words).

The bus controller divides the flat 4 Gbyte memory space into 16 regions; each region has independent software programmable parameters that define data bus width, ready control, number of wait states, pipeline read mode, byte ordering and burst mode. These parameters are stored in the memory region configuration registers MCON 0-15. Each memory region is  $2^{28}$  bytes (256 Mbytes).

The purpose of configurable memory regions is to provide system hardware interface support. Regions are transparent to the software. The address' upper four bits (A31:28) indicate which region is enabled.

A data bus width parameter in each MCON register configures the external data bus as an 8-, 16- or 32-bit bus for a region. This parameter determines byte enable signal encoding and the physical location of data on data bus pins.

When a burst bus mode is enabled, a single address cycle can be followed with up to four data cycles. This mode enables very high speed data bus transfers. When disabled, accesses appear as one data cycle per address cycle. The burst bus mode can be enabled or disabled on a region-by-region basis.

## THE BUS CONTROLLER

A programmable wait state generator inserts a programmed number of wait states into any memory access. These wait states, independently programmable by region, can be specified between:

- address and data cycles
- consecutive data cycles of burst accesses
- the last data cycle and the address cycle of the next request

An external, memory-ready input permits the user's hardware to insert wait states into any memory cycle. This pin works with the wait state generator and is enabled or disabled on a region-by-region basis.

Pipelined read mode provides the highest data bandwidth for reads and instruction fetches. When a region is programmed for pipelined reads, the next read's address cycle overlaps the current read's data cycle.

The bus controller supports big and little endian byte ordering for memory operations. Byte ordering determines how data is read from or written to the bus and ultimately how data is stored in memory.

### 10.2 MEMORY REGION CONFIGURATION

Programmable memory region configurations simplify external memory system designs and reduce system parts count. Certain bus access characteristics may be programmed. This programmed bus scheme allows accesses made to different areas (or regions) in memory to have different characteristics. For example, one area in memory can be configured for slow 8-bit accesses; this is optimal for peripherals. Another area in memory can be configured for 32-bit wide burst accesses; this is optimal for fast DRAM interfaces. Bus function in each region is determined by the memory region configuration. The following bus characteristics are selected for each region:

- Selectable 8-, 16- or 32-bit-wide data bus
- Programmable high performance burst access
- Five wait state parameters
- Memory-ready and burst cycle terminate for dynamic access control
- Programmable pipelined reads
- Big or little endian byte order



These characteristics can be programmed independently for accesses made to each of 16 different regions in memory. The value of the memory address upper four bits (A31:28) determine the selected region. Memory region configuration affects all accesses to the addressed memory region. Loads, stores, DMA transfers and instruction fetches all use the parameters defined for the region.

Programming region characteristics is accomplished by setting values in the memory region configuration (MCON) registers. A separate register allows the user to program the characteristics for each of the 16 memory regions. Memory region configuration registers are described in section 10.3, “PROGRAMMING THE BUS CONTROLLER” (pg. 10-5). The following subsections describe the i960 CX processors’ programmable bus characteristics.

### 10.2.1 Data Bus Width

Each region’s data bus width is programmed in the memory region configuration table. The i960 CX processors allow an 8-, 16- or 32-bit-wide data bus for each region. Byte enable signals encoded in each region provide the proper address for 8-, 16- or 32-bit memory systems. The i960 CX processors use the lower order data lines when reading and writing to 8- or 16-bit memory.

### 10.2.2 Burst and Pipelined Read Accesses

To improve bus bandwidth, the i960 CX devices provide a burst access and pipelined read access. These burst and pipelining modes are separately enabled or disabled for each memory region by programming the memory region configuration table.

When burst access is enabled, the bus controller generates an address — the burst address — followed by one to four data transfers. The lower two address bits (A3:2) are incremented for each consecutive data transfer. Burst accesses facilitate the interface to fast page mode DRAM; wait states following the address cycle and wait states between data cycles can be controlled independently. Data cycle time is typically a fraction of address cycle time. This provides an optimal wait state profile for fast page mode DRAM.

10

When address pipelining is enabled, the next read address is asserted in the last data cycle of the current read access. Pipelining makes the address cycle invisible for back-to-back read accesses.

### 10.2.3 Wait States

A wait state generator within the bus controller generates wait states for a memory access. For many memory interfaces, the internal wait state generator eliminates the necessity to externally generate a memory ready signal to indicate a valid data transfer.

Typically, extra clock cycles — wait states — are associated with each data cycle. Wait states provide the required access times for external memory or peripherals. Five parameters, programmed for each region define wait state generator operation. These parameters are:

## THE BUS CONTROLLER

|           |  |
|-----------|--|
| $N_{RAD}$ | Number of wait cycles for Read Address-to-Data. The number of wait states between address cycle and first read data cycle. Programmable for 0-31 wait states.  |
| $N_{RDD}$ | Number of wait cycles for Read Data-to-Data. The number of wait states between consecutive data cycles of a burst read. Programmable for 0-3 wait states.  |
| $N_{WAD}$ | Number of wait cycles for Write Address-to-Data. The number of wait states that data is held after the address cycle and before the first write data cycle. Programmable for 0-31 wait states.   |
| $N_{WDD}$ | Number of wait cycles for Write Data-to-Data. The number of wait states that data is held between consecutive data cycles of a burst write. Programmable for 0-3 wait states.  |
| $N_{XDA}$ | Number of wait cycles for X (read or write) Data-to-Address. The minimum number of wait states between the last data cycle of a bus request to the address cycle of the next bus request. $N_{XDA}$ applies to read and write requests. Programmable for 0-3 clocks. |

$N_{RAD}$  and  $N_{WAD}$  describe address-to-data wait states.  $N_{RDD}$  and  $N_{WDD}$  specify the number of wait states between consecutive data when burst mode is enabled.  $N_{RDD}$  and  $N_{WDD}$  are not used in non-burst memory regions.

$N_{XDA}$  describes the number of wait states between consecutive bus requests.  $N_{XDA}$  is the bus turnaround time. An external device's ability to relinquish the bus on a read access (read deasserted to data float) determines the number of  $N_{XDA}$  cycles.

**NOTE:**

For pipelined read accesses, the bus controller uses a value of zero (0) for  $N_{XDA}$ , regardless of the parameter's programmed value. A non-zero  $N_{XDA}$  value defeats the purpose of pipelining. The programmed value of  $N_{XDA}$  is used for write requests to pipelined memory regions, as the i960 CX processor does not support pipelined write accesses.

The ready ( $\overline{READY}$ ) and burst terminate ( $\overline{BTERM}$ ) inputs dynamically control bus accesses. These inputs are enabled or disabled for each memory region.  $\overline{READY}$  extends accesses by forcing wait states.  $\overline{BTERM}$  allows a burst access to be broken into multiple accesses, with no lost data. The memory region registers are programmed to enable or disable these inputs for each region.





$\overline{\text{READY}}$  and  $\overline{\text{BTERM}}$  work with the programmed internal wait state counter. If  $\overline{\text{READY}}$  and  $\overline{\text{BTERM}}$  are enabled in a region, these pins are sampled only after the programmed number of wait states expire. If the inputs are disabled in a region, the inputs are ignored and the internal wait state counter alone determines access wait states. Refer to section 11.2.1, “Wait States” (pg. 11-4) for details on the operation of the  $\overline{\text{READY}}$  and  $\overline{\text{BTERM}}$  inputs.

**NOTE:**

$\overline{\text{READY}}$  and  $\overline{\text{BTERM}}$  must be disabled in regions where pipelined reads are enabled.

### 10.2.4 Byte Ordering

Byte ordering determines how data is read from or written to the bus and ultimately how data is stored in memory. Byte ordering can be individually selected for each memory region by setting a bit in the corresponding MCON register. The bus controller supports big endian and little endian byte ordering for memory operations:

*little endian*      The controller reads or writes a data word’s least-significant byte to the bus’ eight least-significant data lines (D7:0). Little endian systems store a word’s least-significant byte at the lowest byte address in memory. For example, if a little endian ordered word is stored at address 600, the least-significant byte is stored at address 600 and the most-significant byte at address 603.

*big endian*      The controller reads or writes a data word’s least-significant byte to the bus’ eight most-significant data lines (D31:24). Big endian systems store the least-significant byte at the highest byte address in memory. So, if a big endian ordered word is stored at address 600, the least-significant byte is stored at address 603 and the most-significant byte at address 600.

10

## 10.3 PROGRAMMING THE BUS CONTROLLER

The bus controller is programmed using 17 control registers, 16 of which are MCON0-15; the remaining one is the Bus Configuration (BCON) register. Control registers are automatically loaded at initialization from the control table in external memory. Control registers are modified by using the load control registers message of the system control (**sysctl**) instruction. See section 2.3, “CONTROL REGISTERS” (pg. 2-6) for control register definition.

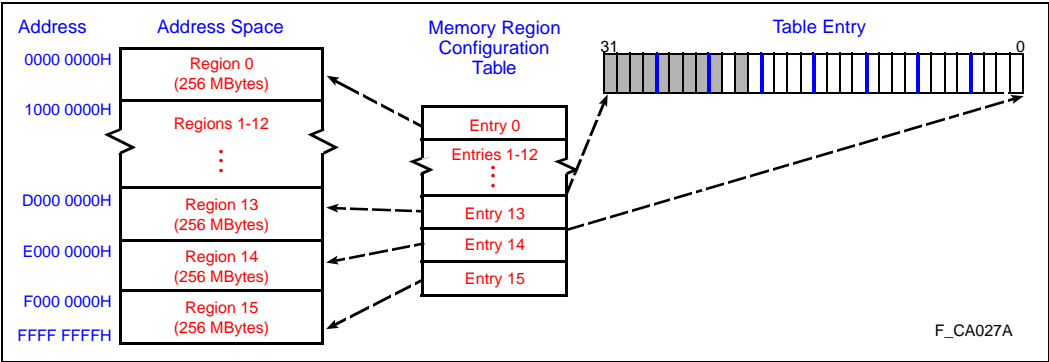
**THE BUS CONTROLLER**

**10.3.1 Memory Region Configuration Registers (MCON 0-15)**

The control table contains 16 memory region control registers MCON 0-15. Each specifies:

- number of wait states
- burst mode
- data bus width
- pipeline mode
- byte ordering
- external ready mode for the region that it controls

An address' four most-significant bits indicate which region is being accessed. Each MCON register is 32 bits wide (see Figure 10-1 and Figure 10-2); however, not all bits are currently used. Table 10-1 defines MCON 0-15 register's programmable bits.



**Figure 10-1. MCON 0-15 Registers Configure External Memory**



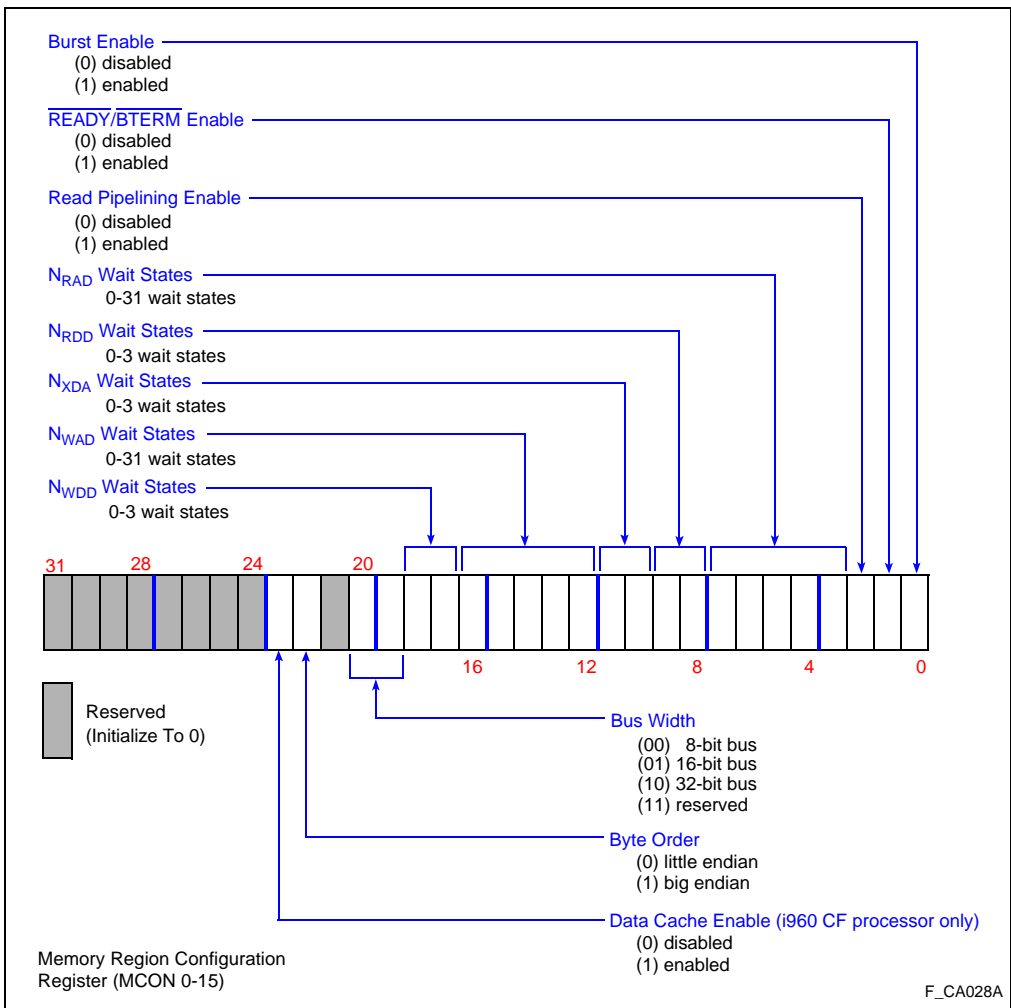


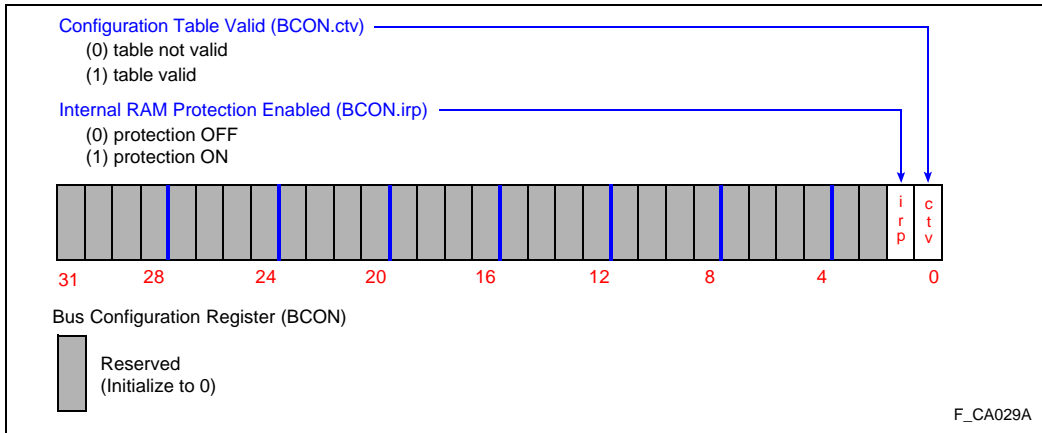
Figure 10-2. Memory Region Configuration Register (MCON 0-15)

**Table 10-1. MCON0-15 Programmable Bits**

| Entry Name                   | Bit # | Definition   |
|------------------------------|-------|--|
| Burst Enable                 | 0     | Enables or disables burst accesses for the region.   |
| READY/BTERM Enable           | 1     | Enables or disables region's $\overline{\text{READY}}$ and $\overline{\text{BTERM}}$ inputs. If disabled, $\overline{\text{READY}}$ and $\overline{\text{BTERM}}$ are ignored.       |
| Read Pipelining Enable       | 2     | Enables or disables address pipelining of region's read accesses. $\overline{\text{READY}}$ and $\overline{\text{BTERM}}$ are ignored during pipelined reads.                        |
| N <sub>RAD</sub> Wait States | 3-7   | Number of Read Address-to-Data wait states in the region. (Programmed for 0-31 Wait States)  |
| N <sub>RDD</sub> Wait States | 8-9   | Number of Read Data-to-Data wait states in the region. (Programmed for 0-3 Wait States)  |
| N <sub>XDA</sub> Wait States | 10-11 | Number of X (read or write) Data-to-Address wait states in the region. (Programmed for 0-3 Wait States). N <sub>XDA</sub> wait states are only inserted at the end of a bus request. |
| N <sub>WAD</sub> Wait States | 12-16 | Number of Write Address-to-Data wait states in the region. (Programmed for 0-31 Wait States)   |
| N <sub>WDD</sub> Wait States | 17-18 | Number of Write Data-to-Data wait states in the region. (Programmed for 0-3 Wait States)   |
| Bus Width                    | 19-20 | Determines region's data bus width. Effects encoding of byte-enable signals BE3:0  |
| Byte Ordering                | 22    | Selects region's byte ordering: little endian or big endian.   |

**10.3.2 Bus Configuration Register (BCON)**

The Bus Configuration (BCON) register (Figure 10-3) is a 32-bit register that controls MCON 0-15 and internal data RAM protection. Table 10-2 defines the BCON register's programmable bits.



**Figure 10-3. Bus Configuration Register (BCON)**

**Table 10-2. BCON Register Bit Definitions**

| Entry Name                | Bit # | Definition   |
|---------------------------|-------|--|
| Configuration Table Valid | 0     | When BCON.ctv bit is clear, all memory is accessed as defined by MCON 0. When BCON.ctv bit is set, MCON 0-15 are used. |
| Internal RAM Protection   | 1     | Enables supervisor write protection for internal data RAM at address 100H to 3FFH.                                     |

### 10.3.3 Configuring the Bus Controller

The bus controller is configured automatically when the processor initializes. All MCON 0-15 values are loaded from the control table and the BCON.ctv bit is set (table valid) before the first instruction of application code executes. The user only has to supply the correct value in the control table in external memory. See CHAPTER 14, INITIALIZATION AND SYSTEM REQUIREMENTS for more details on the processor’s actions at initialization.

MCON 0-15 values may be altered after initialization by use of the **sysctl** instruction. It is important to avoid altering an enabled MCON register while a bus access to that region is in progress. It is acceptable, however, to write the same data to an enabled MCON register while a bus access to that region is in progress. This consideration is especially important for MCON 0, when it is the master entry (BCON.ctv = 0).

## 10.4 DATA ALIGNMENT

Aligned bus requests generate an address that occurs on a data type’s natural boundary. Quad words and triple words are aligned on 16-byte boundaries; double words on 8-byte boundaries; words on 4-byte boundaries; short words (half words) on 2-byte boundaries; bytes on 1-byte boundaries.

Unaligned bus requests do not occur on these natural boundaries. Any unaligned bus request to a little endian memory region is executed; however, unaligned requests to big endian regions are supported only if software adheres to particular address alignment restrictions.

The processor handles all unaligned bus requests to little endian memory regions. It executes unaligned little endian requests as several aligned requests. This method of handling an unaligned bus request results in some performance loss compared to aligned requests: microcode uses CPU cycles to generate aligned requests and more bus cycles are used to transfer unaligned data.

The processor may generate an operation-unaligned fault when any unaligned request is encountered. This fault can be masked with the PRCB fault configuration word.

## THE BUS CONTROLLER

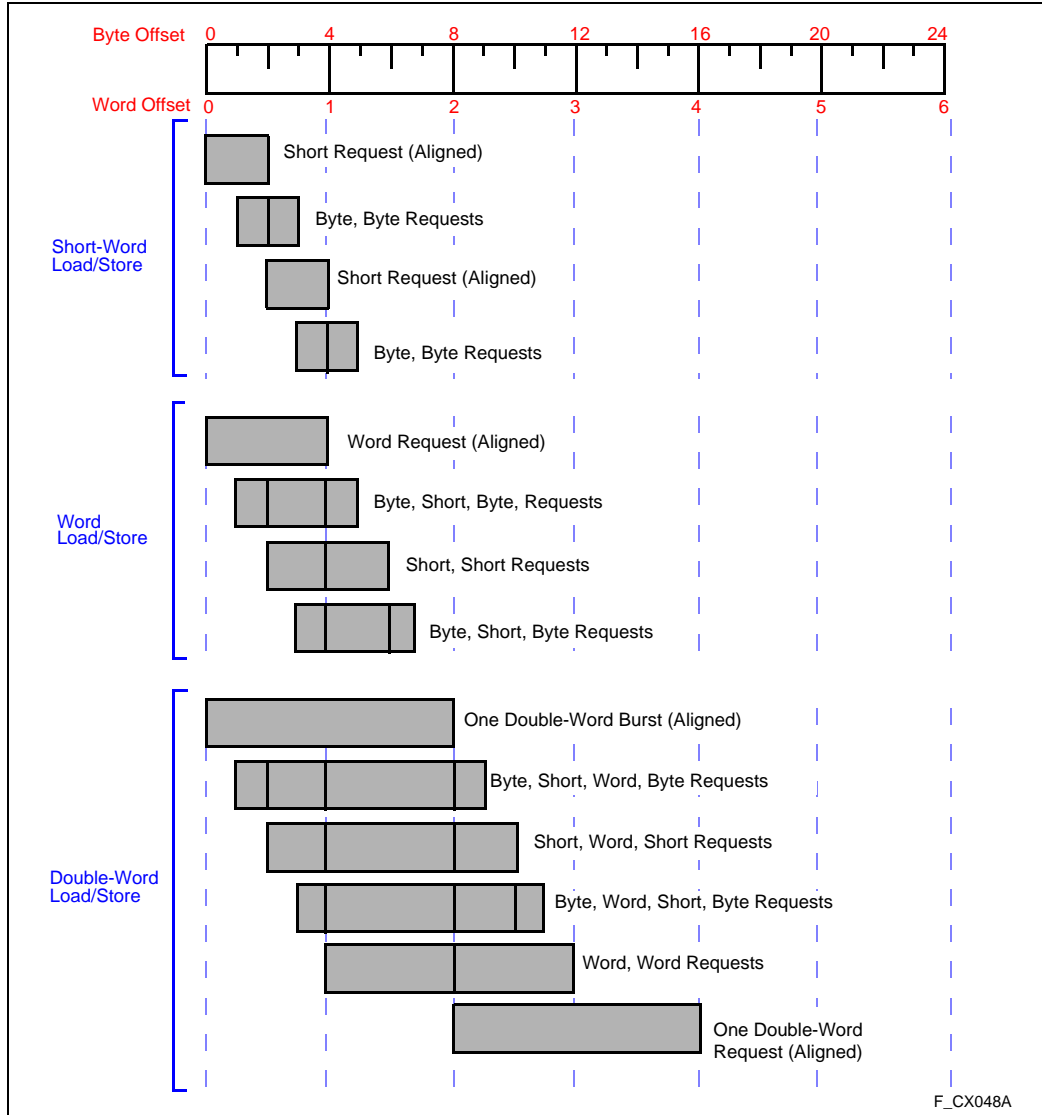
When the processor encounters an unaligned request, microcode breaks the unaligned request into a series of aligned requests. For example, if a read request is issued to read a little endian word from address XXXX XXX1H (unaligned), a byte request followed by a short request followed by a byte request is executed. Figure 10-4 and Figure 10-5 show how aligned and unaligned bus transfers are carried out for memory regions that use little endian byte ordering.

If the unaligned fault is not masked, the bus controller executes the unaligned access — the same as it does when the fault is masked — and signals an operation-unaligned fault. The unaligned access fault can be used as a debug feature. Removing unaligned memory accesses from an application increases performance.

### NOTE:

When an unsupported unaligned bus request to a big endian region is attempted, the bus controller handles the transfer exactly the same as it does for little endian regions; that is, it treats the data as little endian data. Thus, the data is not stored coherently in memory.





10

Figure 10-4. Summary of Aligned-Unaligned Transfers for Little Endian Regions

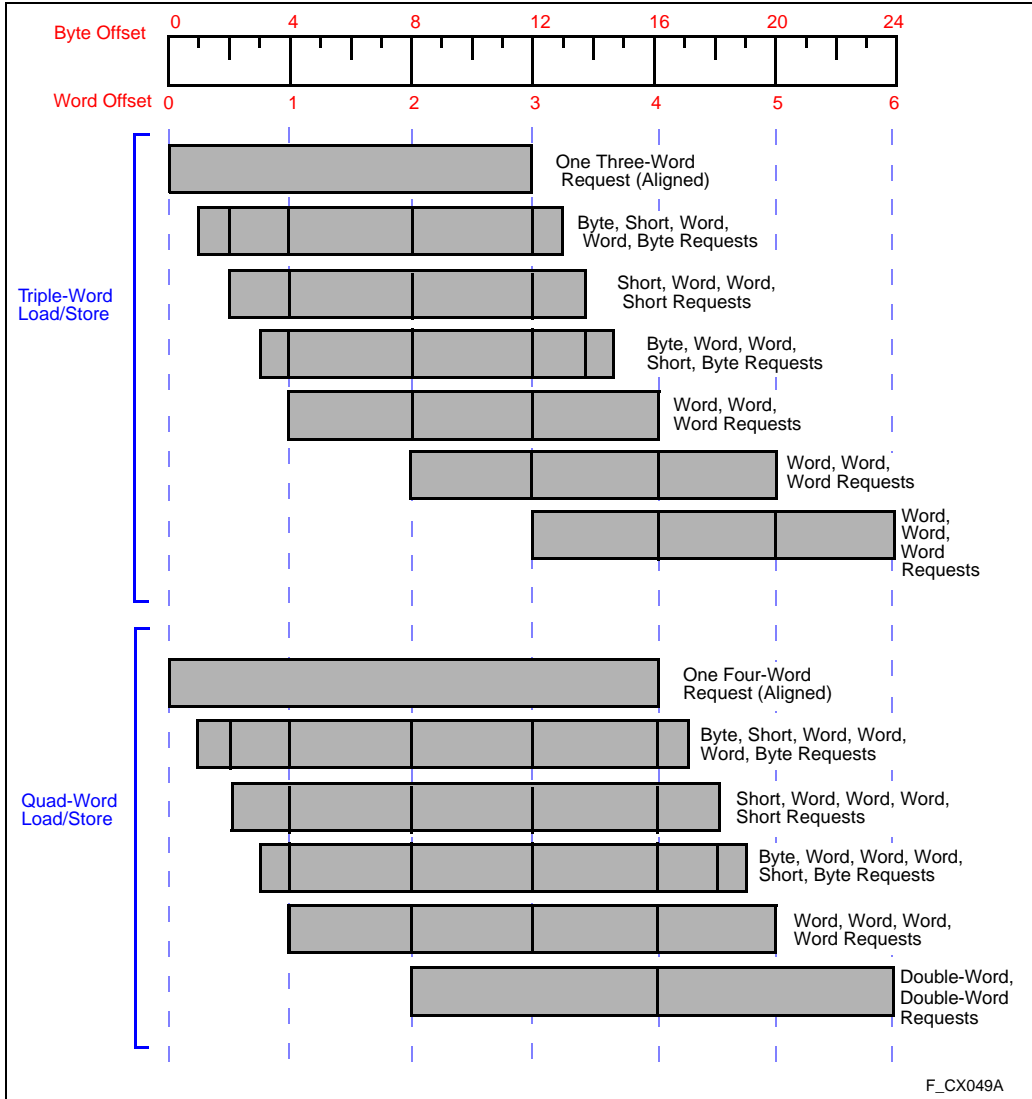


Figure 10-5. Summary of Aligned-Unaligned Transfers for Little Endian Regions (continued)





## 10.5 INTERNAL DATA RAM

The i960 Cx processor contains 1 Kbyte of user-visible internal data RAM which is mapped into the first 1 Kbyte of the address space (addresses 00H – 3FFH). Internal data RAM is accessed only by loads, stores or DMA transfers. Instruction fetches directed to these addresses cause an operation-unimplemented fault to occur.

A portion of this internal data RAM is optionally used to store DMA status, cached interrupt vectors and, in some applications, cached local registers. The remaining data RAM can be used by application software. Refer to section 2.5.4, “Internal Data RAM” (pg. 2-12).

Internal data RAM interfaces directly to an internal 128-bit bus. This bus is the pathway between registers and data RAM. Because of the wide internal path, a quad word read or write is usually performed in a single clock.

## 10.6 BUS CONTROLLER IMPLEMENTATION

The bus controller consists of four units (see Figure 10-6):

- bus queue
- data packing unit
- translation unit
- sequencer

The i960 Cx processors’ instruction fetch unit, execution unit and DMA unit all pass memory requests to the bus controller unit which arbitrates, queues and executes these requests.

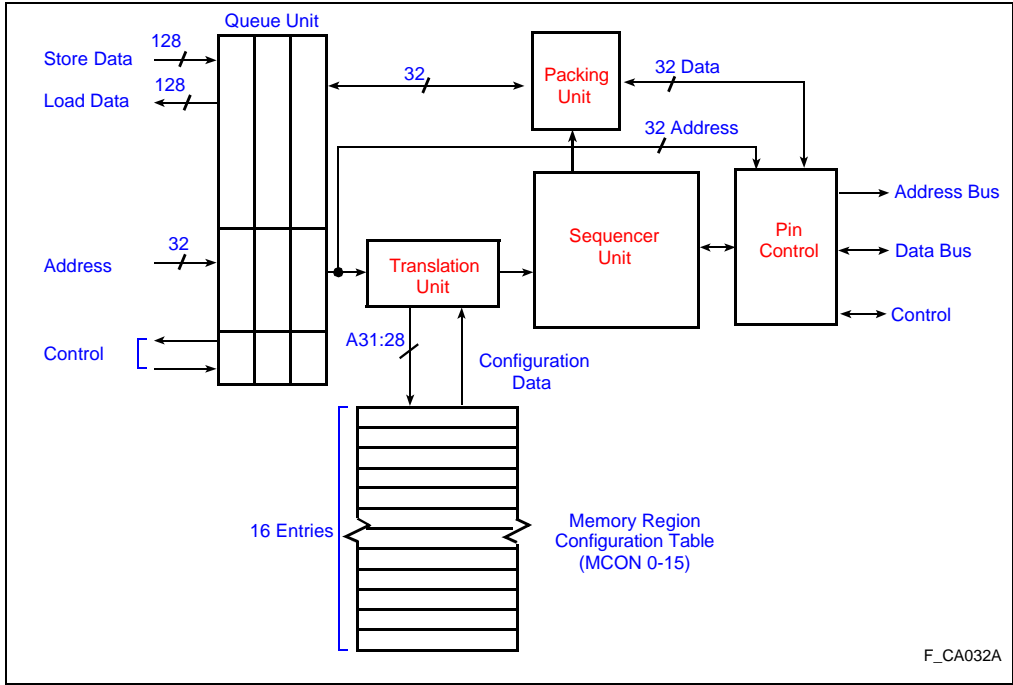


Figure 10-6. Bus Controller Block Diagram

10.6.1 Bus Queue

The bus controller has a queue which contains entries for up to three bus requests. Each queue entry consists of a 32-bit address, up to 128 bits of data (four words) and control information. The bus queue decouples high bandwidth (128-bit-wide data) internal data buses from the lower bandwidth (32-bit-wide data) external bus.

Two of these queue entries are reserved for bus requests generated from user code. The third queue entry is used by the DMA controller. If no DMA channels are set up, the third slot is also used by user code. User requests are serviced in a first-in, first-out (FIFO) manner. The DMA does not issue back-to-back requests; therefore, the CPU is guaranteed access to the external bus between DMA accesses, thus allowing the user and DMA processes to execute concurrently while sharing the external bus.

Queue depth affects bus request and interrupt latency. Queued requests must be serviced before the pending request can be serviced. If an interrupt occurs when all three bus queue entries are full, the three outstanding requests must be serviced before the first interrupt instruction may be fetched from memory.



### 10.6.2 Data Packing Unit

The data packing unit handles data movement between queues and external bus. It controls data alignment and data packing:

- Data is unpacked when data store request width exceeds physical bus width
- Data is packed when data load request width exceeds physical bus width

If a word load is issued to an 8-bit bus, the bus controller issues four 1-byte reads and the data packing unit assembles incoming data into a single word. If a quad word-store is issued to an 8-bit bus, the bus controller issues four 4-byte writes and the data packing unit unpacks the outgoing data.

### 10.6.3 Bus Translation Unit and Sequencer

The bus translation unit is responsible for looking up the memory configuration in the region table. The look-up is based on the bus request's address. The bus request and region table data are passed to the bus sequencer when the external bus is available. The sequencer then breaks the request into a set of bus accesses; this generates the signals on the external bus pins.



# EXTERNAL BUS DESCRIPTION





# CHAPTER 11

## EXTERNAL BUS DESCRIPTION

This chapter discusses the bus pins, bus transactions and bus arbitration. It shows waveforms to illustrate some common bus configurations. This chapter serves as a guide for the hardware designer when interfacing memory and peripherals to the i960® Cx processors. For further details on external bus operation, refer to APPENDIX B, BUS INTERFACE EXAMPLES. For information on bus controller configuration, refer to CHAPTER 10, THE BUS CONTROLLER. For pin descriptions, refer to the 80960CA and CF data sheets.

### 11.1 OVERVIEW

The i960 Cx processors' integrated bus controller and external bus provide a flexible, easy-to-use interface to memory and peripherals. All bus transactions are synchronized with the processor clock outputs (PCLK2:1); therefore, most memory system control logic can be implemented as state machines. The internal programmable wait state generator, external ready control signals, bus arbitration signals, data transceiver control signals and programmable bus width parameters all combine to reduce system component count and ease the design task.

#### 11.1.1 Terminology: Requests and Accesses

The terms *request* and *access* are used frequently when referring to bus controller operation. The description of the bus modes and burst bus operation is simplified by defining these terms.

**11**

##### 11.1.1.1 Request

The terms request, bus request or memory request describe interaction between the core and bus controller. The bus controller is designed to decouple, as much as possible, bus activity from instruction execution in the core. When a load or store instruction or instruction prefetch is issued, the core delivers a bus request to the bus controller unit.

The bus controller unit independently processes the request and retrieves data from memory for load instructions and instruction prefetches. The bus controller delivers data to memory for store instructions. The i960 architecture defines byte, short word, word, double word, triple word and quad word data lengths for load and store instructions.

When a load or store instruction is encountered, the core issues to the bus controller a bus request of the appropriate data length: for example, **ldq** requests that four words of data be retrieved from memory; **stob** requests that a single byte is delivered to memory.

The processor fetches instructions using double or quad word bus requests. Its microcode issues load and store requests to perform DMA transfers.

#### 11.1.1.2 Access

The terms access, bus access or memory access describe the mechanism for moving data or instructions between the bus controller and memory. An access is bounded by the assertion of  $\overline{ADS}$  (address strobe) and  $\overline{BLAST}$  (burst last) signals, which are outputs from the processor.  $\overline{ADS}$  indicates that a valid memory address is present and an access has started.  $\overline{BLAST}$  indicates that the next data which is transferred is the end of access. The bus controller can be configured to initiate burst, non-burst or pipelined accesses. A burst access begins with  $\overline{ADS}$  followed by two to four data transfers. The last data transfer is indicated by assertion of  $\overline{BLAST}$ . Non-burst accesses begin with assertion of  $\overline{ADS}$  followed by a single data transfer. Pipelined accesses begin on the same clock cycle in which the previous cycle completes. This is accomplished by asserting  $\overline{ADS}$  and a valid address during the last data transfer of the previous cycle. Pipelined accesses may also be burst or non-burst.

The bus controller can be configured for various modes to optimize interfaces to external memory. Access type — burst, non-burst or pipelined — is selected when the bus controller is configured.

#### 11.1.2 Configuration

The bus controller can be configured in various ways. Bus width and access type can be set based on external memory system requirements. For example, peripheral devices commonly have slow, non-burst, 8-bit buses. The bus controller can be configured to make memory accesses to these 8-bit non-burst devices. Each memory access to the peripheral begins with assertion of  $\overline{ADS}$  and a valid address.  $\overline{BLAST}$  is asserted and, after the desired number of wait states, eight bits of data are transferred.

A peripheral device is accessed as described above regardless of which bus request type is issued. For example, if a program includes a **ld** (word load instruction) from the peripheral, the load is executed as four 8-bit accesses to the peripheral.

### 11.2 BUS OPERATION

As described in Table 11-1, the i960 Cx processor bus consists of 30 address signals, four byte enables, 32 data lines and various control and status signals. Some signals are referred to as status signals. A status signal is valid for the duration of a bus request. Other signals are referred to as control signals. Control signals are used to define and manage a bus request. This chapter defines the bus pins and pin function.





Table 11-1. Bus Controller Pins

| Pin Name                | Description             | Input/Output |
|-------------------------|-------------------------|--------------|
| PCLK2:1                 | Processor Output Clocks | O            |
| D31:0                   | Data Bus                | I/O          |
| A31:2                   | Address Bus             | O            |
| <b>Control Signals:</b> |                         |              |
| $\overline{BE3:0}$      | Byte Enables            | O            |
| $\overline{ADS}$        | Address Strobe          | O            |
| $\overline{WAIT}$       | Wait States             | O            |
| $\overline{BLAST}$      | Burst Last              | O            |
| $\overline{READY}$      | Memory Ready            | I            |
| $\overline{BTERM}$      | Burst Terminate         | I            |
| $\overline{DEN}$        | Data Enable             | O            |
| <b>Status Signals:</b>  |                         |              |
| $\overline{W/R}$        | Write/Read              | O            |
| $\overline{DT/R}$       | Data Transmit/Receive   | O            |
| $\overline{D/C}$        | Data/Code Request       | O            |
| $\overline{DMA}$        | DMA Request             | O            |
| $\overline{SUP}$        | Supervisor Mode Request | O            |
| <b>Bus Arbitration:</b> |                         |              |
| HOLD                    | Hold Request            | I            |
| HOLDA                   | Hold Acknowledge        | O            |
| $\overline{LOCK}$       | Locked Request          | O            |
| BREQ                    | Bus Request Pending     | O            |
| $\overline{BOFF}$       | Bus Backoff             | I            |

A bus access starts with an address cycle; address cycle is defined by the assertion of address strobe ( $\overline{ADS}$ ). Address and byte enables (A31:2 and  $\overline{BE3:0}$  are also presented in the address cycle.

After the address cycle, extra clock cycles called wait states may be inserted to accommodate the access time for external memory or peripherals. For write accesses, the data lines are driven during wait states. For read accesses, data lines float. Wait states are discussed in section 11.2.1, “Wait States” (pg. 11-4).

A data cycle follows wait states. For write accesses, the data cycle is the last clock cycle in which valid data is driven onto the data bus. For read accesses, external memory must present valid data on the rising edge of PCLK2:1 during the data cycle. Setup and hold time for input data is specified in the 80960CA and CF data sheets.



## EXTERNAL BUS DESCRIPTION

A bus access may be either non-burst or burst. A non-burst access ends after one data cycle to a single memory location. A burst access involves two to four data cycles to consecutive memory locations.  $\overline{\text{BLAST}}$  — the burst last signal — is asserted to indicate the last data cycle of an access. section 10.2.2, “Burst and Pipelined Read Accesses” (pg. 10-3) explains how to configure the bus controller for burst or non-burst accesses.

Read accesses may be pipelined. (Write accesses are not pipelined in the i960 CX architecture.) In a pipelined access, the data cycle and address cycle of two accesses overlap. This is possible because address and data lines are not multiplexed. A valid address can be presented on the address bus while a previous access ends with a data transfer on the data bus. section 10.2.2, “Burst and Pipelined Read Accesses” (pg. 10-3) explains how to configure the bus for pipelined accesses.

$\text{W}/\overline{\text{R}}$  is a status signal which discerns between a write request (store) or a read request (load or prefetch).

$\text{DT}/\overline{\text{R}}$  and  $\overline{\text{DEN}}$  pins are used to control data transceivers. Data transceivers may be used in a system to isolate a memory subsystem or control loading on data lines.  $\text{DT}/\overline{\text{R}}$  is used to control transceiver direction; the signal is low for read requests and high for write requests.  $\text{DT}/\overline{\text{R}}$  is valid on the falling  $\text{PCLK2:1}$  edge during the address cycle.  $\overline{\text{DEN}}$  is used to enable the transceivers; it is asserted on the rising  $\text{PCLK2:1}$  edge following the address cycle.  $\text{DT}/\overline{\text{R}}$  and  $\overline{\text{DEN}}$  timings ensure that  $\text{DT}/\overline{\text{R}}$  does not change when  $\overline{\text{DEN}}$  is asserted.

$\text{D}/\overline{\text{C}}$ ,  $\overline{\text{DMA}}$  and  $\overline{\text{SUP}}$  provide information about the source of bus request.  $\text{D}/\overline{\text{C}}$  indicates that the current request is data or a code fetch.  $\overline{\text{DMA}}$  indicates that the current request is a DMA access.  $\overline{\text{SUP}}$  indicates that the current request was originated by a supervisor mode process. When used with a logic analyzer, these signals aid in software debugging.

$\text{D}/\overline{\text{C}}$  may also be used to implement separate external data and instruction memories.  $\overline{\text{SUP}}$  can be used to protect hardware from accesses while the processor is not in user mode.

The bus is in the idle state between bus requests. Idle bus state begins after  $\text{N}_{\text{XDA}}$  cycles and ends when  $\overline{\text{ADS}}$  is asserted.

The bus controller aligns all bus accesses; non-aligned accesses are translated into a series of smaller aligned accesses. Alignment is described in section 10.4, “DATA ALIGNMENT” (pg. 10-9).

### 11.2.1 Wait States

In non-burst mode, it is possible to insert wait states between the address and data cycle. In a burst mode access, it is possible to insert wait states between the address cycle and data cycle and between subsequent data cycles for a burst access. It is also possible to insert wait states between bus accesses which occur back-to-back.



The i960 Cx processors' bus controller provides an internal counter for automatically inserting wait states. The bus controller provides control of five different wait state parameters. Figure 11-1 and the following text describe each parameter.

|           |   |
|-----------|---|
| $N_{RAD}$ | Number of wait cycles for Read Address-to-Data. The number of wait states between the address cycle and first read data cycle. $N_{RAD}$ can be programmed for 0-31 wait states.  |
| $N_{RDD}$ | Number of wait cycles for Read Data-to-Data. The number of wait states between consecutive data cycles of a burst read. $N_{RDD}$ can be programmed for 0-3 wait states.  |
| $N_{WAD}$ | Number of wait cycles for Write Address-to-Data. The number of wait states that data is held after the address cycle and before the first write data cycle. $N_{WAD}$ can be programmed for 0-31 wait states.   |
| $N_{WDD}$ | Number of wait cycles for Write Data-to-Data. The number of wait states that data is held between consecutive data cycles of a burst write. $N_{WDD}$ can be programmed for 0-3 wait states.  |
| $N_{XDA}$ | Number of wait cycles for X (read or write) Data to Address. The minimum number of wait states between the last data cycle of a bus request to the address cycle of the next bus request. $N_{XDA}$ applies to read and write requests. $N_{XDA}$ can be programmed for 0-3 clocks. |

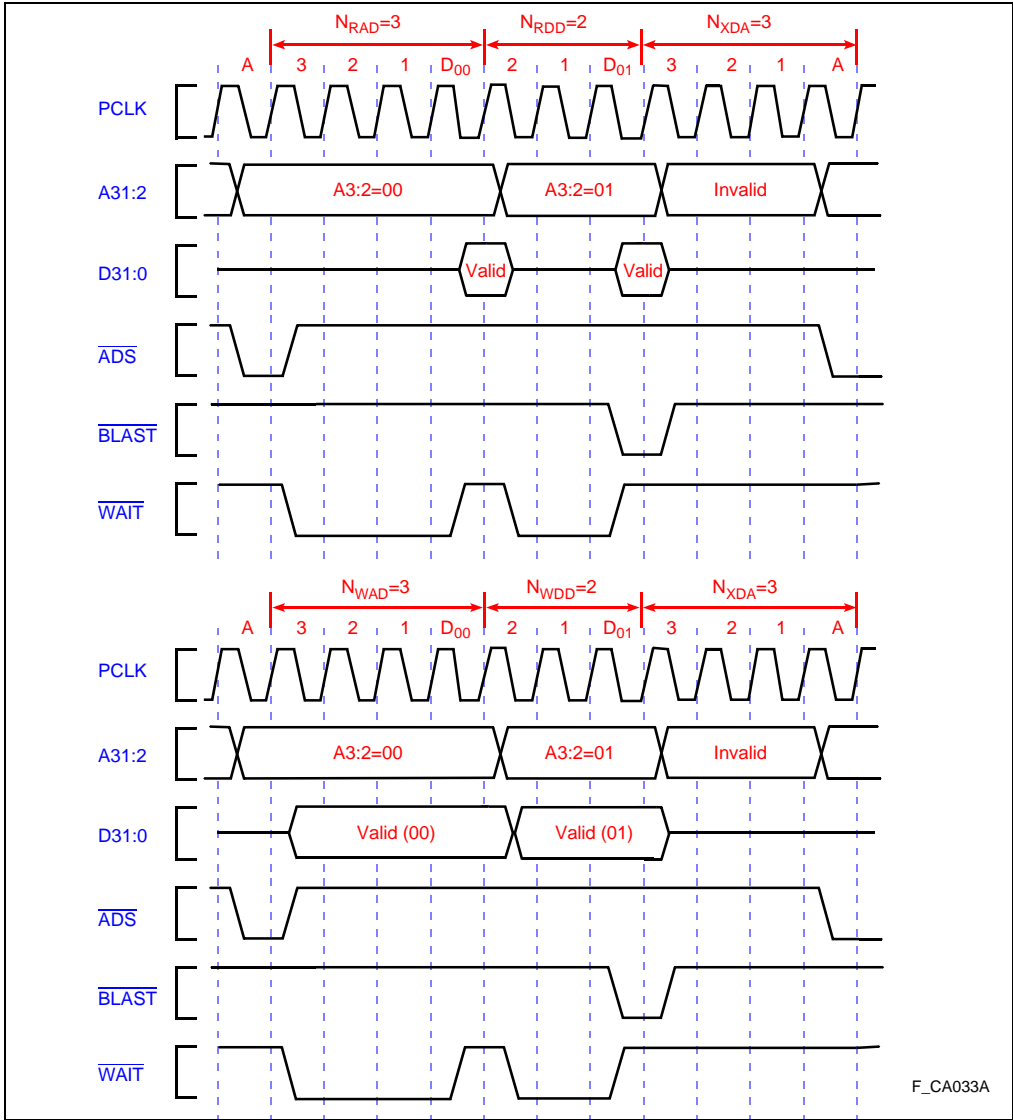
$N_{RAD}$  and  $N_{WAD}$  describe address-to-data wait states;  $N_{RDD}$  and  $N_{WDD}$  specify the number of wait states between consecutive data when burst mode is enabled.  $N_{RDD}$  and  $N_{WDD}$  are not used in non-burst memory regions.

$N_{XDA}$  describes the number of wait states between consecutive bus requests.  $N_{XDA}$  is the bus turnaround time. An external device's ability to relinquish the bus on a read request (read deasserted to data-float) determines the number of  $N_{XDA}$  cycles.

11

**NOTE:**

$N_{XDA}$  states are only inserted after the last data transfer of a bus request. Therefore, for requests composed of multiple accesses,  $N_{XDA}$  states do not appear between each access. For example, on an 8-bit burst bus,  $N_{XDA}$  states are inserted only after the fourth byte of a word request rather than after every byte. (See Figure 11-2.)



**Figure 11-1. Internal Programmable Wait States**

For pipelined read accesses, the bus controller uses a value of zero for the  $N_{XDA}$  parameter, regardless of the programmed value for the parameter. A non-zero  $N_{XDA}$  value defeats the purpose of pipelining. The programmed value of  $N_{XDA}$  is used for write requests to pipelined memory regions.



The processor asserts the  $\overline{\text{WAIT}}$  signal when  $N_{\text{RAD}}$ ,  $N_{\text{WAD}}$ ,  $N_{\text{RDD}}$  or  $N_{\text{WDD}}$  are inserted.  $\overline{\text{WAIT}}$  can be used as a read or write strobe for the external memory system.

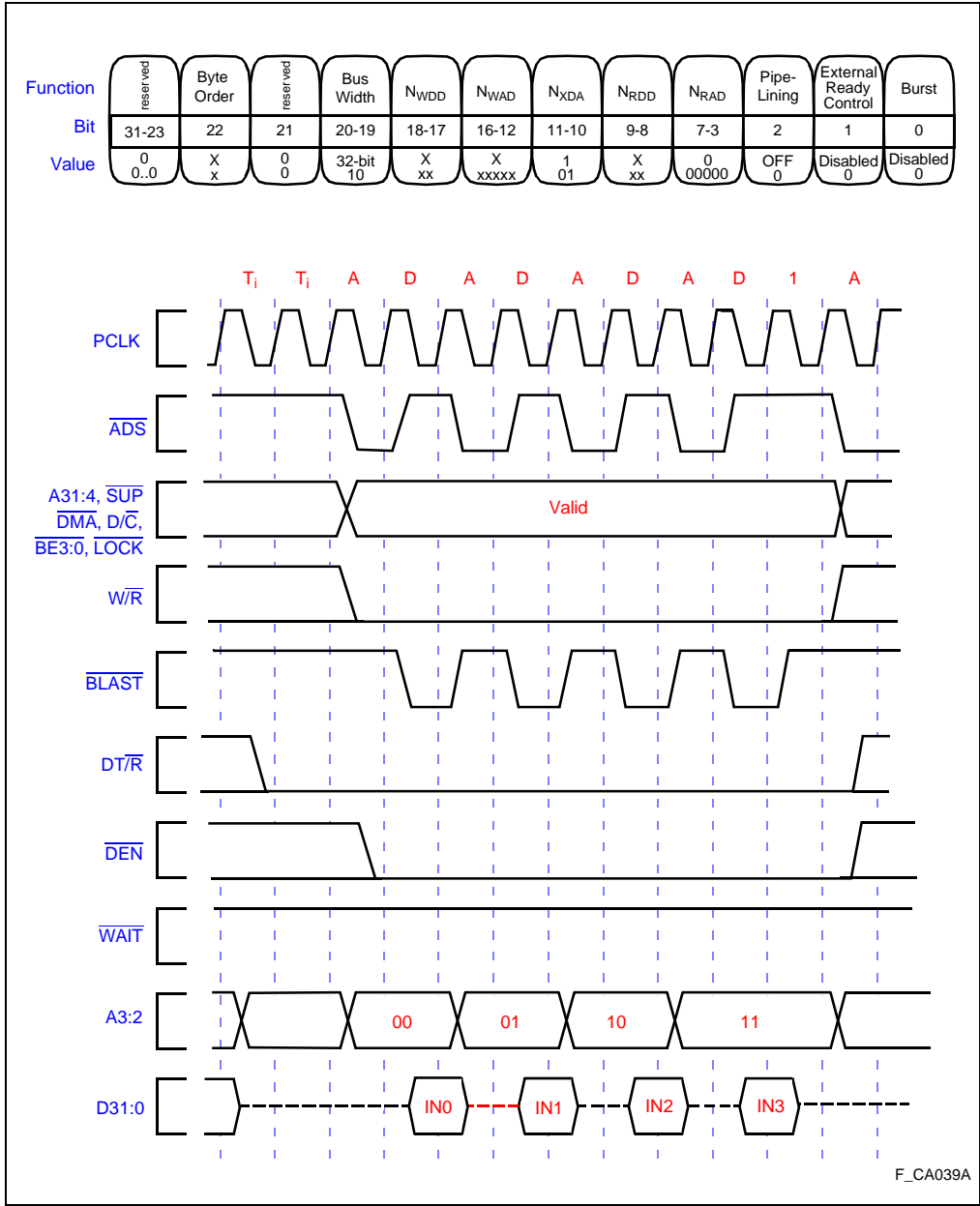
Wait states can also be controlled with  $\overline{\text{READY}}$  and  $\overline{\text{BTERM}}$ . These inputs are enabled or disabled in a region by programming the memory region configuration table. Refer to section 10.2.3, “Wait States” (pg. 10-3) for details on setting up bus controller for wait states.

When enabled,  $\overline{\text{READY}}$  indicates to the processor that read data on the bus is valid or a write data transfer has completed. The  $\overline{\text{READY}}$  pin value is ignored until the  $N_{\text{RAD}}$ ,  $N_{\text{RDD}}$ ,  $N_{\text{WAD}}$  or  $N_{\text{WDD}}$  wait states expire. At this time, if  $\overline{\text{READY}}$  is deasserted (high), wait states continue to be inserted until  $\overline{\text{READY}}$  is asserted (low).

$N_{\text{XDA}}$  wait states cannot be extended by  $\overline{\text{READY}}$ . The  $\overline{\text{READY}}$  input is ignored during the idle cycles, the address cycle and  $N_{\text{XDA}}$  cycles.  $\overline{\text{READY}}$  is also ignored in memory regions where pipelining is enabled, regardless of memory region programming. For proper operation, the  $\overline{\text{READY}}$  inputs should be disabled in regions that have pipelining enabled.

The burst terminate signal ( $\overline{\text{BTERM}}$ ) breaks up a burst access. Asserting  $\overline{\text{BTERM}}$  (low) for one clock cycle completes the current data transfer and invokes another address cycle. This allows a burst access to be dynamically broken into smaller accesses. The resulting accesses may also be burst accesses. For example, if  $\overline{\text{BTERM}}$  is asserted after the first word of a quad word burst, the bus controller initiates another access by asserting  $\overline{\text{ADS}}$ . The accompanying address is the address of the second word of the burst access ( $A3:2 = 01_2$ ). The bus controller then bursts the remaining three words. The  $\overline{\text{BLAST}}$  (burst last) signal indicates the last data transfer of the access.

Read data is accepted on the clock edge that asserts  $\overline{\text{BTERM}}$ ; write data is assumed written.  $\overline{\text{BTERM}}$  effectively overrides the memory ready ( $\overline{\text{READY}}$ ) signal when it is asserted. In this way, no data is lost when the current access is terminated. When  $\overline{\text{BTERM}}$  is asserted,  $\overline{\text{READY}}$  is ignored until after the address cycle which resumes the burst. As with  $\overline{\text{READY}}$ ,  $\overline{\text{BTERM}}$  is ignored when pipelining is enabled in a region, regardless of how the region is programmed. For proper operation, the  $\overline{\text{BTERM}}$  inputs should be disabled in regions that have pipelining enabled.



Errata 10/31/94 SRB.  
Wait signal incorrectly shown as transitioning; it now correctly shows that the signal is asserted high throughout.

Figure 11-2. Quad-word Read from 32-bit Non-burst Memory

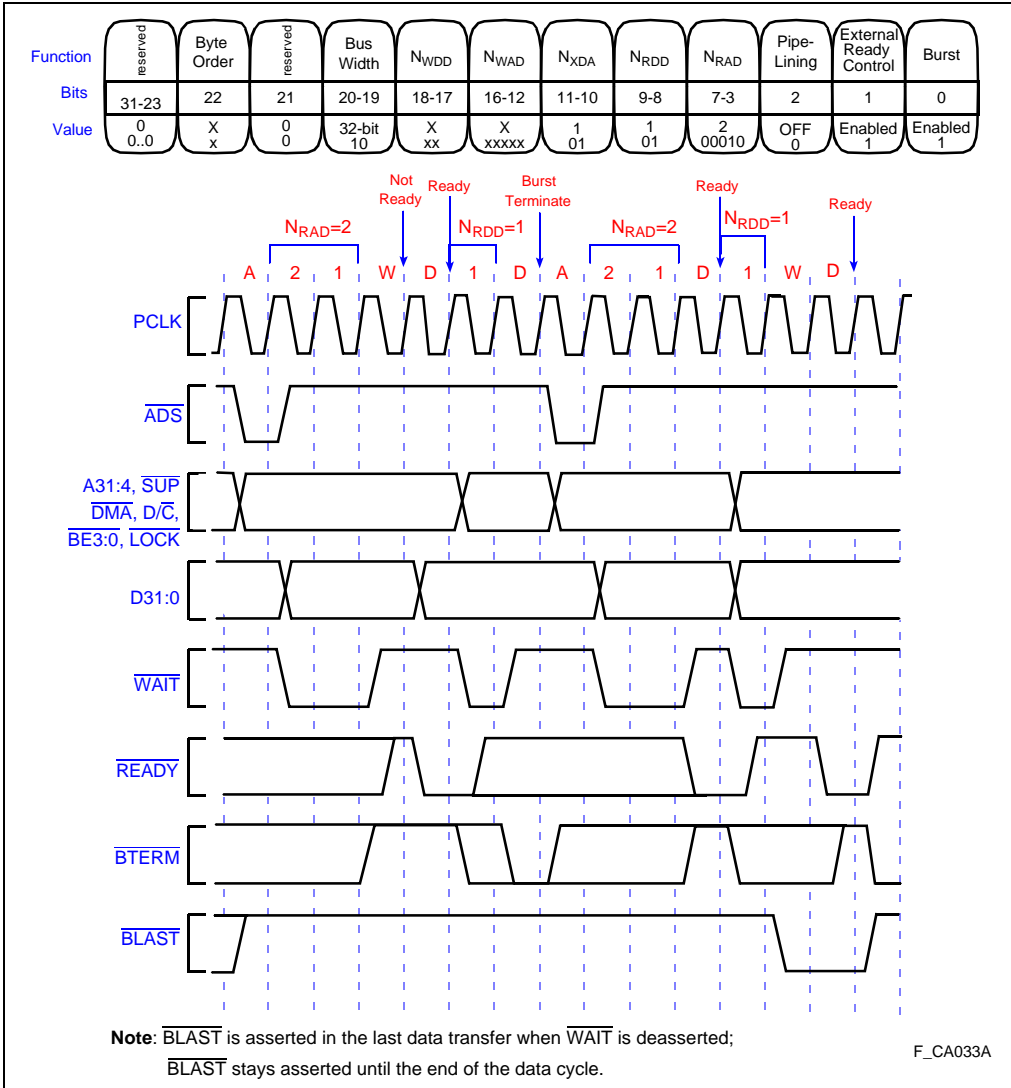


Figure 11-3. Bus Request with  $\overline{\text{READY}}$  and  $\overline{\text{BTERM}}$  Control

11.2.2 Bus Width

Each region’s data bus width is programmed in the memory region configuration table. The i960 Cx processors allow an 8-, 16- or 32-bit-wide data bus for each region. The i960 Cx processors place 8- and 16-bit data on low order data pins. This simplifies interface to external devices. As shown in Figure 11-4, 8-bit data is placed on lines D7:0; 16-bit data is placed on lines D15:0; 32-bit data is placed on lines D31:0.

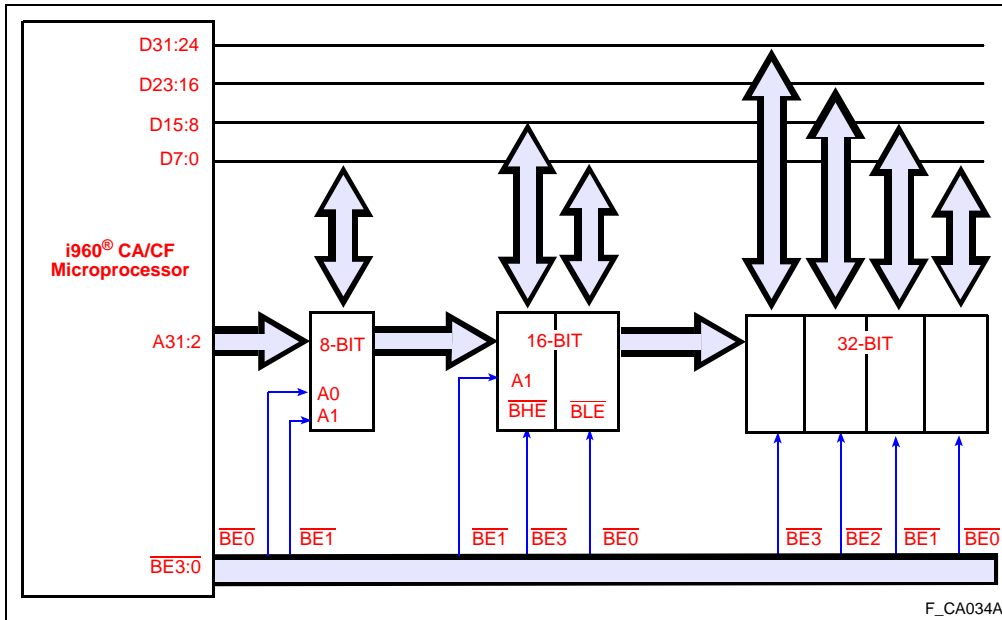


Figure 11-4. Data Width and Byte Enable Encodings

The four byte enable signals are encoded in each region to generate proper address signals for 8-, 16- or 32-bit memory systems:

- 8-bit region:  $\overline{BE0}$  is address line A0;  $\overline{BE1}$  is address line A1.
- 16-bit region:  $\overline{BE1}$  is address line A1;  $\overline{BE3}$  is the byte high enable signal ( $\overline{BHE}$ );  $\overline{BE0}$  is the byte low enable signal ( $\overline{BLE}$ ).
- 32-bit region: byte enables are not encoded. Byte enables  $\overline{BE3:0}$  select byte 3 to byte 0, respectively. Address lines A31:2 provide the most significant portion of the address. (See Table 11-2.)





For regions configured for 8- and 16-bit bus widths, data is repeated on the upper data lines for aligned store operations. When storing a value to an 8-bit bus region, the processor drives the same byte-wide data onto lines D7:0, D15:8, D23:16 and D31:24 simultaneously. When storing a value to memory in a 16-bit bus region, the processor drives the same short-word data onto lines D15:0 and D31:16 simultaneously.

**Table 11-2. Byte Enable Encoding**

**8-Bit Bus Width:**

| BYTE | $\overline{BE3}$ (X) | $\overline{BE2}$ (X) | $\overline{BE1}$ (A1) | $\overline{BE0}$ (A0) |
|------|----------------------|----------------------|-----------------------|-----------------------|
| 0    | X                    | X                    | 0                     | 0                     |
| 1    | X                    | X                    | 0                     | 1                     |
| 2    | X                    | X                    | 1                     | 0                     |
| 3    | X                    | X                    | 1                     | 1                     |

**16-Bit Bus Width:**

| BYTE | $\overline{BE3}$ (BHE) | $\overline{BE2}$ (X) | $\overline{BE1}$ (A1) | $\overline{BE0}$ (BLE) |
|------|------------------------|----------------------|-----------------------|------------------------|
| 0,1  | 0                      | X                    | 0                     | 0                      |
| 2,3  | 0                      | X                    | 1                     | 0                      |
| 0    | 1                      | X                    | 0                     | 0                      |
| 1    | 0                      | X                    | 0                     | 1                      |
| 2    | 1                      | X                    | 1                     | 0                      |
| 3    | 0                      | X                    | 1                     | 1                      |

**32-Bit Bus Width:**

| BYTE    | $\overline{BE3}$ | $\overline{BE2}$ | $\overline{BE1}$ | $\overline{BE0}$ |
|---------|------------------|------------------|------------------|------------------|
| 0,1,2,3 | 0                | 0                | 0                | 0                |
| 2,3     | 0                | 0                | 1                | 1                |
| 0,1     | 1                | 1                | 0                | 0                |
| 0       | 1                | 1                | 1                | 0                |
| 1       | 1                | 1                | 0                | 1                |
| 2       | 1                | 0                | 1                | 1                |
| 3       | 0                | 1                | 1                | 1                |



### 11.2.3 Non-Burst Requests

A basic request (non-burst, non-pipelined; see Figure 11-5) is an address cycle followed by a single data cycle, including any optional wait states associated with the request. Wait states may be generated internally by the wait state generator or externally using the i960 Cx processors'  $\overline{\text{READY}}$  input.

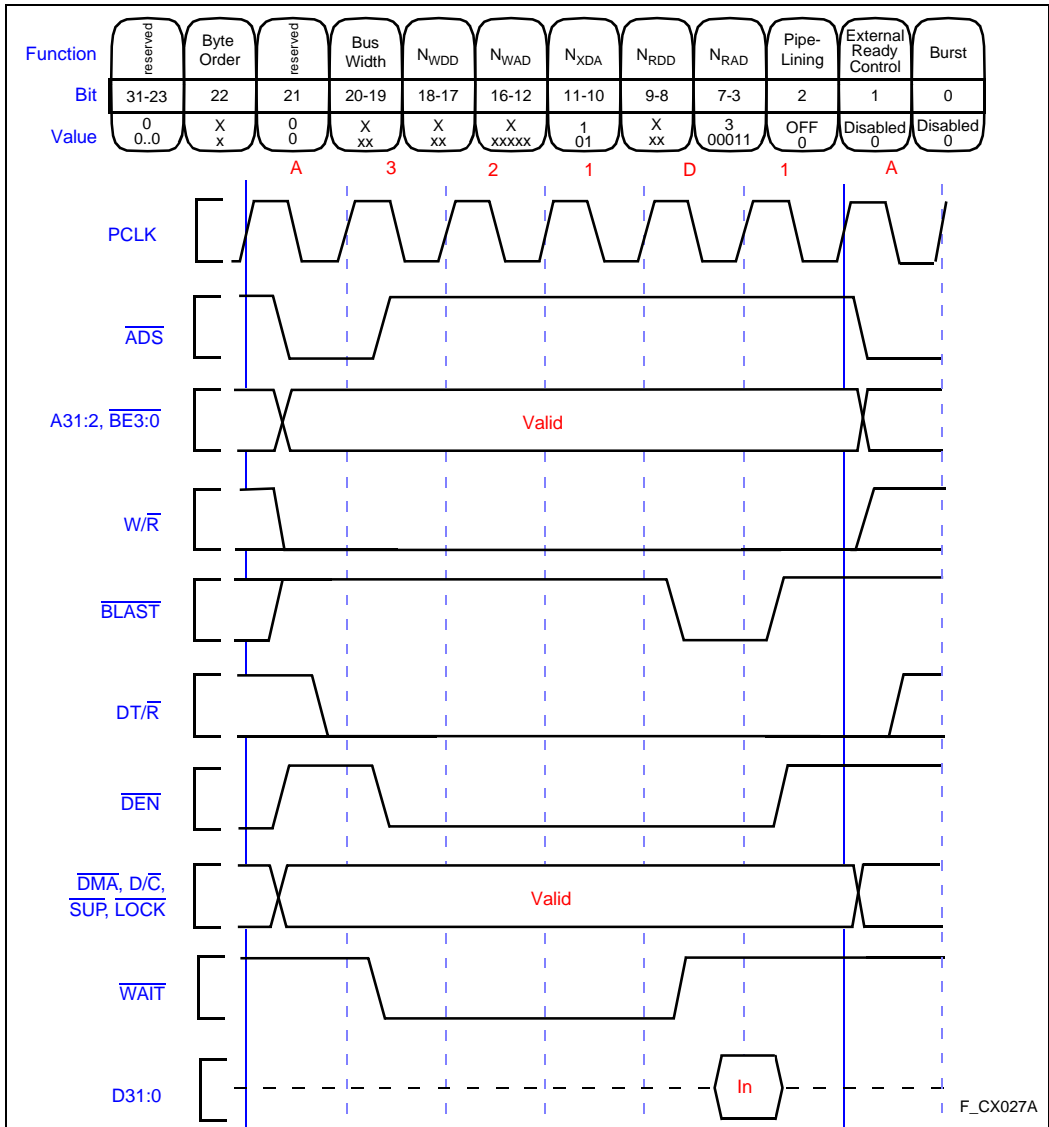


Figure 11-5. Basic Read Request, Non-Pipelined, Non-Burst, Wait-States

Non-burst accesses and non-pipelined reads are the most basic form of memory access. Non-burst regions may be used to memory map peripherals and memory that cannot support burst accesses. Ready control may be enabled or disabled for the region.

$N_{RAD}$ ,  $N_{WAD}$  and  $N_{XDA}$  wait state fields of a region table entry control basic accesses:

- $N_{RAD}$  specifies the number of wait states between address and data cycles for read accesses.
- $N_{WAD}$  specifies the number of wait states between address and data cycle for write accesses.
- $N_{XDA}$  specifies the number of wait states between data cycle and next address cycle.

Data-to-data wait states ( $N_{RDD}$ ,  $N_{WDD}$ ) are not used if burst accesses are not enabled.

A read access begins by asserting the proper address and status signals ( $\overline{ADS}$ , A31:2,  $\overline{BE3:0}$ ,  $\overline{SUP}$ ,  $D/\overline{C}$ ,  $\overline{DMA}$ ,  $W/\overline{R}$ ) on the rising clock edge that begins the address cycle (marked as “A” on the figures). Assertion of  $\overline{ADS}$  indicates the beginning of an access.

$DT/\overline{R}$  is driven on the clock’s next falling edge. This signal is asserted early to ensure that  $DT/\overline{R}$  does not change while  $\overline{DEN}$  is asserted.  $\overline{DEN}$  is asserted on the clock’s next rising edge (the rising edge in which  $\overline{ADS}$  is deasserted and the address cycle ends).  $\overline{DEN}$  can be used to control external data transceivers.

The cycles that follow are  $N_{RAD}$  wait states.  $\overline{WAIT}$  is asserted while the internal wait state generator is counting. If  $\overline{READY/BTERM}$  control is enabled in this region and  $\overline{READY}$  is not asserted after the wait state generator has finished counting, wait states continue to be inserted until  $\overline{READY}$  is asserted.

$\overline{BLAST}$  assertion indicates end of data transfer cycles for this access.  $\overline{DEN}$  is deasserted.  $N_{XDA}$  wait states (turnaround wait states) follow  $\overline{BLAST}$ ; a new address cycle may start after  $N_{XDA}$  cycles expire.  $N_{XDA}$  states allow time for slow devices to get off the bus. For this figure, this access is the last access of a bus request because  $N_{XDA}$  wait states are inserted and  $\overline{DEN}$  is deasserted.

11

#### 11.2.4 Burst Accesses

A burst access is an address cycle followed by two to four data cycles. The two least-significant address signals automatically increment during a burst access.

Maximum burst size is four data cycles. This maximum is independent of bus width. A byte-wide bus has a maximum burst size of four bytes; a word-wide bus has a maximum of four words. If a quad word load request (e.g., **ldq**) is made to an 8 bit data region, it results in four 4-byte burst accesses. (See Table 11-3.)

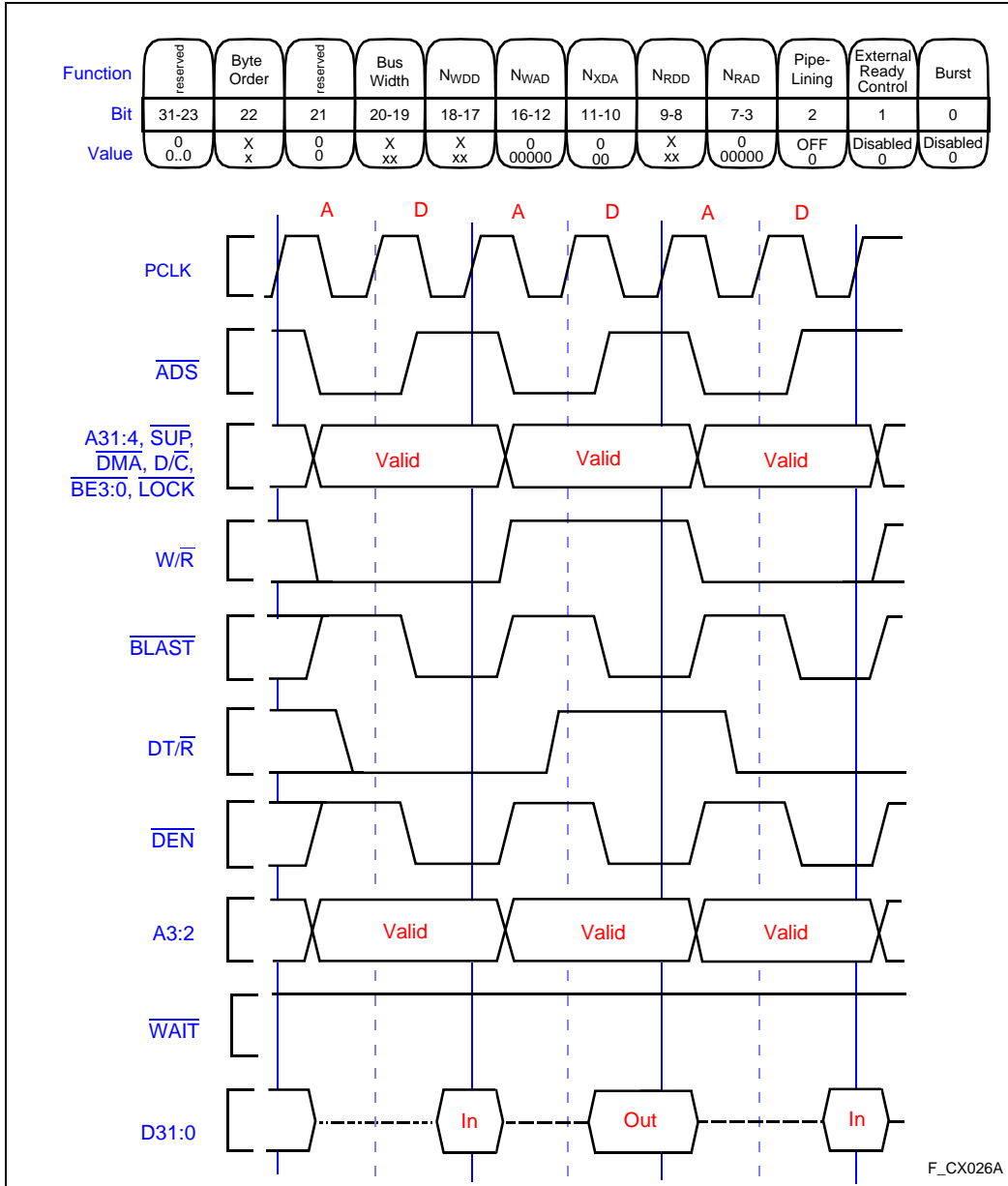


Figure 11-6. Read / Write Requests, Non-Pipelined, Non-Burst, No Wait States



Table 11-3. Burst Transfers and Bus Widths

| Request     | Bus Width | Number of Burst Accesses | Number of Transfers / Burst | Number of Transfers |
|-------------|-----------|--------------------------|-----------------------------|---------------------|
| Quad Word   | 8 bit     | 4                        | 4-4-4-4                     | 16                  |
|             | 16 bit    | 2                        | 4-4                         | 8                   |
|             | 32 bit    | 1                        | 4                           | 4                   |
| Triple Word | 8 bit     | 3                        | 4-4-4                       | 12                  |
|             | 16 bit    | 2                        | 4-2                         | 6                   |
|             | 32 bit    | 1                        | 3                           | 3                   |
| Double Word | 8 bit     | 2                        | 4                           | 8                   |
|             | 16 bit    | 1                        | 4                           | 4                   |
|             | 32 bit    | 1                        | 2                           | 2                   |
| Word        | 8 bit     | 1                        | 4                           | 4                   |
|             | 16 bit    | 1                        | 2                           | 2                   |
|             | 32 bit    | 1                        | 1                           | 1                   |
| Short       | 8 bit     | 1                        | 2                           | 2                   |
|             | 16 bit    | 1                        | 1                           | 1                   |
|             | 32 bit    | 1                        | 1                           | 1                   |
| Byte        | 8 bit     | 1                        | 1                           | 1                   |
|             | 16 bit    | 1                        | 1                           | 1                   |
|             | 32 bit    | 1                        | 1                           | 1                   |

Burst accesses increase bus bandwidth over non-burst accesses. The i960 Cx processors' burst access allows up to four consecutive data cycles to follow a single address cycle. Compared to non-burst memory systems, burst mode memory systems achieve greater performance out of slower memory. SRAM, interleaved SRAM, Static Column Mode DRAM and Fast Page Mode DRAM may be easily designed into burst-mode memory systems.

A burst read or write access consists of: a single address cycle, 0 to 31 address-to-data wait states ( $N_{RAD}$  or  $N_{WAD}$ ) and one to four data cycles, separated by zero to three data-to-data wait states ( $N_{RDD}$  or  $N_{WDD}$ ). If  $\overline{READY/BTERM}$  control is enabled in the region,  $N_{RAD}$ ,  $N_{WAD}$ ,  $N_{RDD}$  and  $N_{WDD}$  wait states may all be extended by not asserting  $\overline{READY}$ .  $\overline{BTERM}$  may be used to break a burst access into smaller accesses.

The address' two least-significant bits automatically increment after each burst data cycle. This is true for 8-, 16- and 32-bit-wide data buses. When a memory region is configured for a 32-bit data bus width, address pins A3:2 increment. For a 16-bit memory region,  $\overline{BE1}$  is encoded as A1 and address pins A2:1 increment. When a memory region is configured for an 8-bit data bus width,  $\overline{BE0}$  and  $\overline{BE1}$  — acting as the lower two bits of the address — increment.

Maximum burst size is four data transfers per access. For an 8- or 16-bit bus, this means that some bus requests may result in multiple burst accesses. For example, a quad-word (16 byte) request to an 8 bit memory results in four 4-byte burst accesses. Each burst access is limited to four byte-wide data transfers.

Burst accesses on a 32-bit bus are always aligned to even-word boundaries. Quad-word and triple-word accesses always begin on quad-word boundaries (A3:2=00); double-word transfers always begin on double-word boundaries (A2=0); single-word transfers occur on single word boundaries. (See Figure 11-7.)

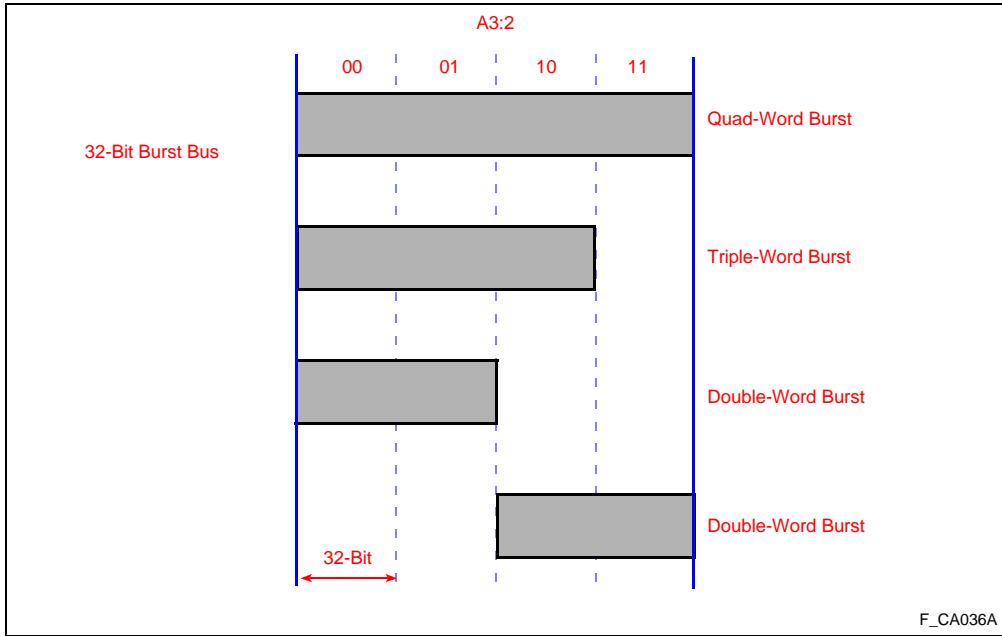


Figure 11-7. 32-Bit-Wide Data Bus Bursts

Burst accesses for a 16-bit bus are always aligned to even short-word boundaries. A four short-word burst access always begins on a four short-word boundary (A2=0, A1=0). Two short-word burst accesses always begin on an even short-word boundary (A1=0). Single short-word transfers occur on single short-word boundaries (see Figure 11-8). For a 16-bit bus, data is transferred on data pins D15:0. Data is also driven on upper data lines D31:16.

Burst accesses for an 8-bit bus are always aligned to even byte boundaries. Four-byte burst accesses always begin on a 4-byte boundary (A1=0, A0=0). Two-byte burst accesses always begin on an even byte boundary (A0=0) (see Figure 11-9). For an 8-bit bus, data is transferred on data pins D7:0. Data is also driven on the upper bytes of the data bus D15:8, D23:16 and D31:24.



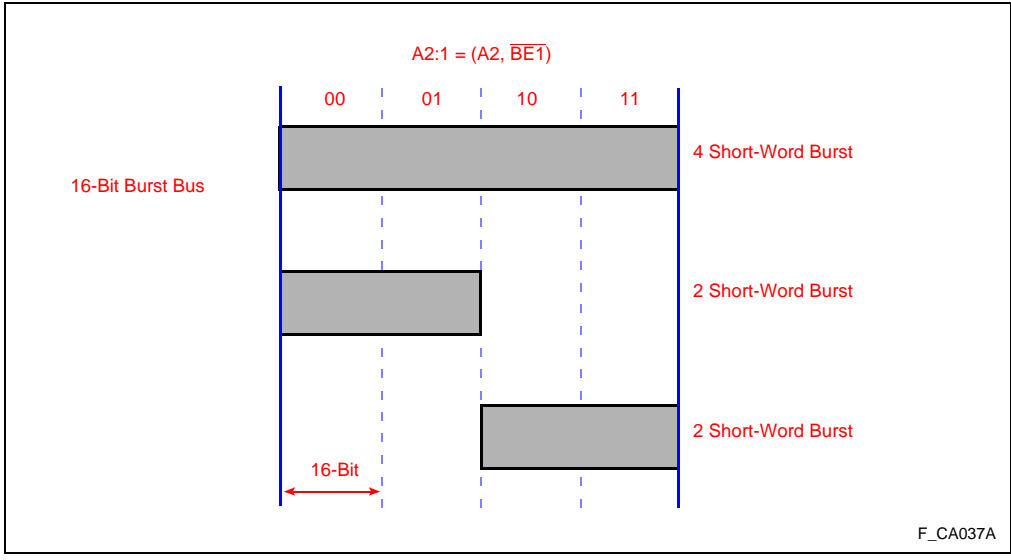


Figure 11-8. 16-Bit Wide Data Bus Bursts

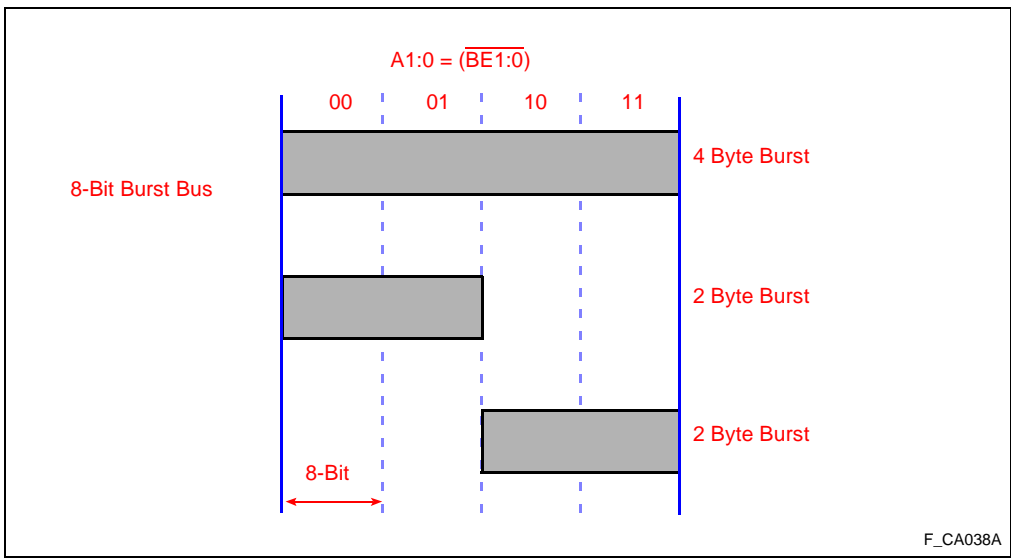


Figure 11-9. 8-Bit Wide Data Bus Bursts

## EXTERNAL BUS DESCRIPTION

Figure 11-10 shows a quad-word read on a 32-bit bus; Figure 11-11 shows a write. Burst access begins by asserting the proper address and status signals ( $\overline{ADS}$ ,  $A_{31:2}$ ,  $\overline{BE3:0}$ ,  $\overline{SUP}$ ,  $D/\overline{C}$ ,  $\overline{DMA}$ ,  $W/\overline{R}$ ). This is done on the rising edge that begins the address cycle (“A” on the figures). Word read asserts all byte enable signals  $\overline{BE3:0}$ .  $\overline{ADS}$  assertion indicates beginning of access.

$DT/\overline{R}$  is driven on the clock’s next falling edge to ensure that  $DT/\overline{R}$  does not change while  $\overline{DEN}$  is asserted.  $\overline{DEN}$  is asserted on the clock’s next rising edge — the rising edge that ends the address cycle.  $\overline{ADS}$  is deasserted on this clock edge.  $\overline{DEN}$  is used to control external data transceivers.  $\overline{DEN}$  and  $DT/\overline{R}$  remain asserted throughout the burst access.

Wait-state cycles that follow an address are  $N_{RAD}$  wait states.  $\overline{WAIT}$  is asserted while the internal wait-state generator is counting. If  $\overline{READY/BTERM}$  control is enabled in this region and  $\overline{READY}$  and  $\overline{BTERM}$  are not asserted after the wait-state generator has finished counting, wait states continue to be inserted until  $\overline{READY}$  is asserted. If  $\overline{BTERM}$  is asserted,  $\overline{READY}$  is ignored. Data is then read and a new address cycle is generated.

The data cycle is followed by  $N_{RDD}$  wait states. These wait states separate burst data cycles and can be used to extend data access time of reads and data setup and hold times for writes.

$\overline{BLAST}$  assertion indicates the end of data transfer cycles for this access. At this time,  $\overline{DEN}$  is deasserted.

$N_{XDA}$  wait states (turnaround wait states) are inserted after the last access of a bus request.  $N_{XDA}$  wait states follow  $\overline{BLAST}$  only when  $\overline{BLAST}$  is asserted for the last access of a bus request. A new address cycle may start after  $N_{XDA}$  cycles have expired.  $N_{XDA}$  states allow slow devices to get off the bus.





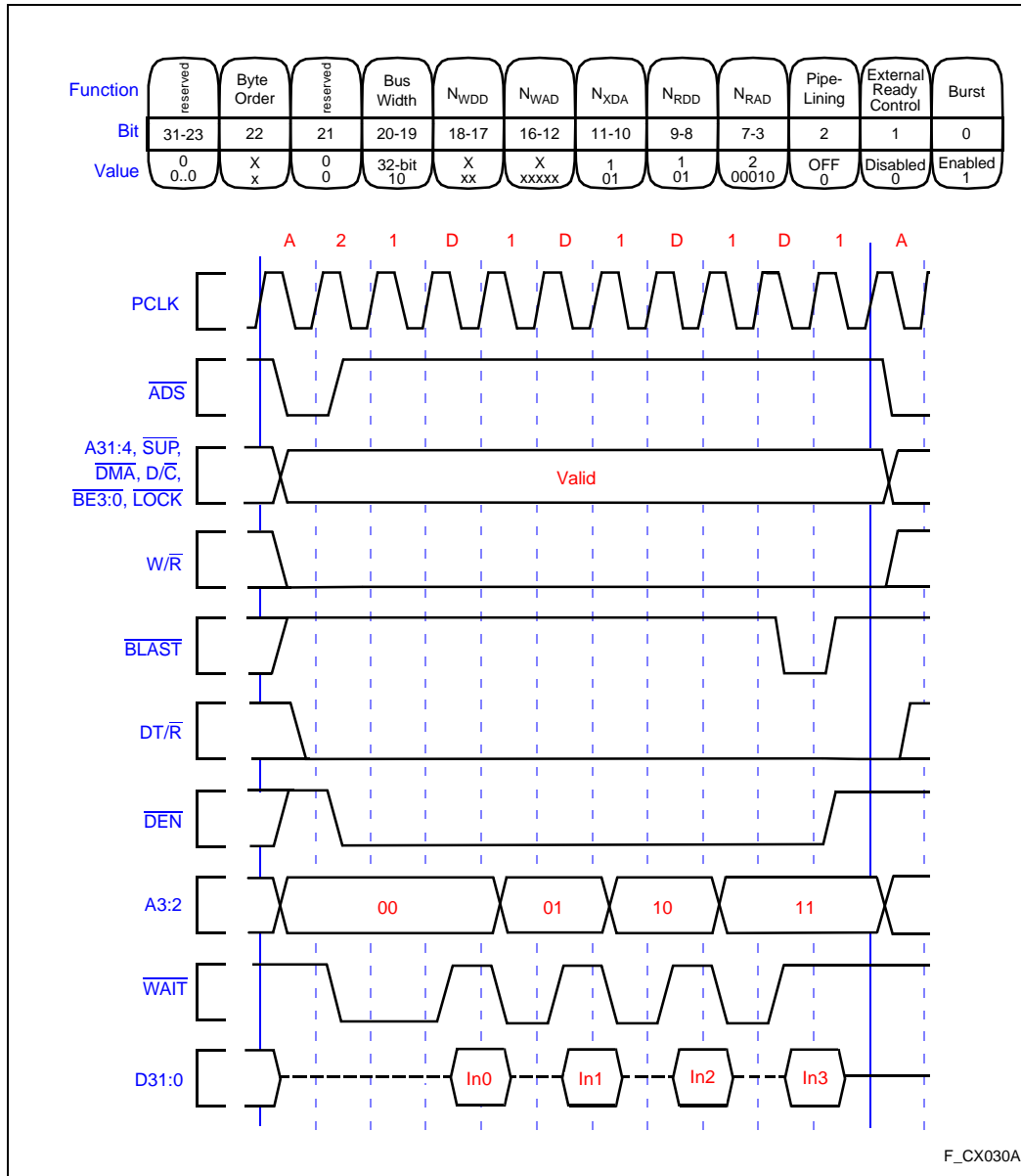


Figure 11-10. 32-Bit Bus, Burst, Non-Pipelined, Read Request with Wait States

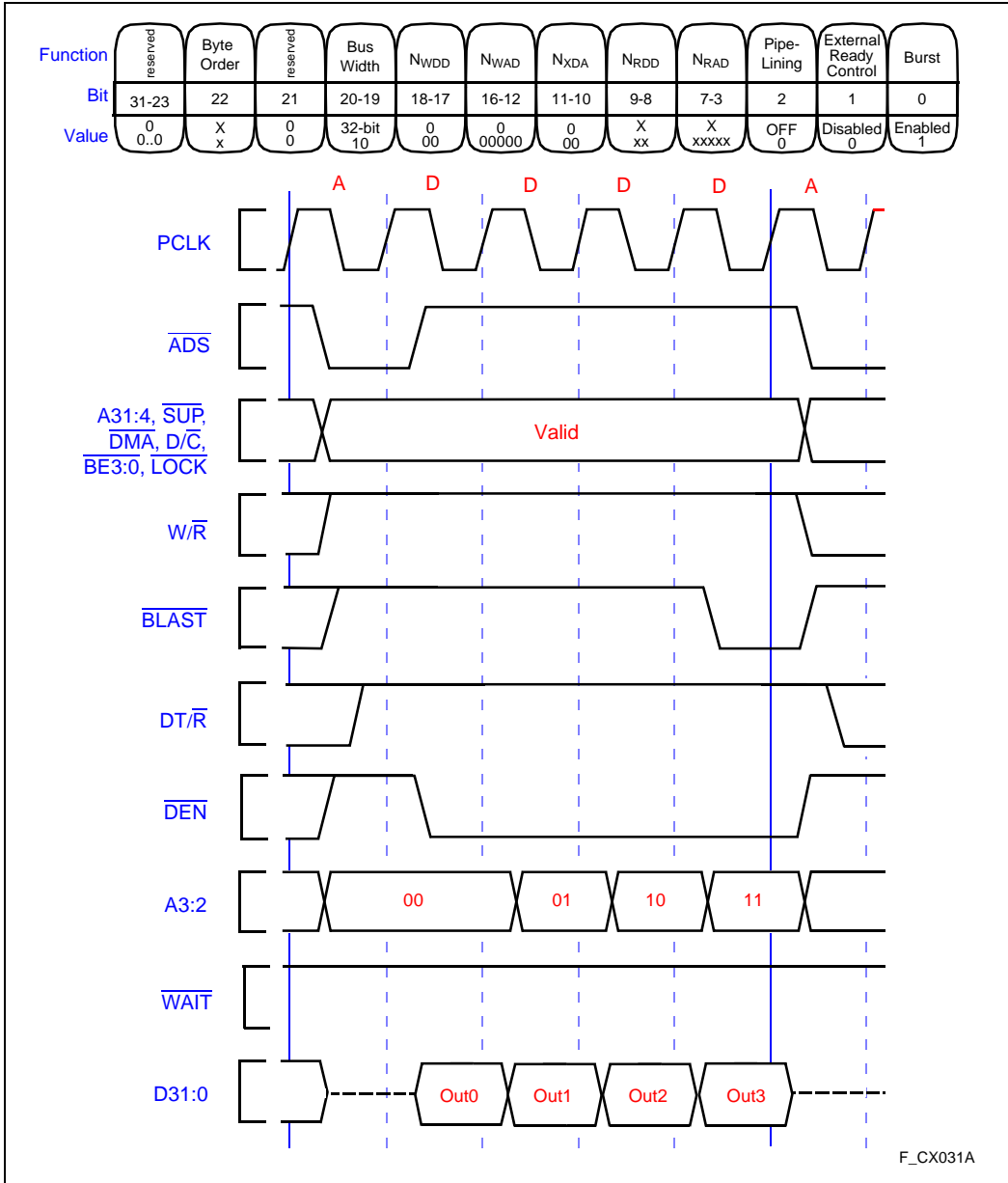


Figure 11-11. 32-Bit Bus, Burst, Non-Pipelined, Write Request without Wait States



### 11.2.5 Pipelined Read Accesses

Pipelined read accesses provide the maximum data bandwidth. For pipelined reads, the next address is output during the current data cycle. This effectively removes the address cycle from consecutive pipelined accesses.

A pipelined read memory system is implemented by adding an address latch to the design (see Figure 11-12). The address latch holds the address for the current read access while the processor outputs the address for the next access. This allows the next address to be available during the data cycle of the current access. Overlapping address and data cycles improves data bandwidth.

Write accesses to a pipelined region act the same as writes to a non-pipelined region. This means that the address for a write access is not pipelined. Similarly, the address for a read access following a write is not pipelined.

**NOTE:**

When pipelining is enabled in a region,  $\overline{\text{READY}}$  and  $\overline{\text{BTERM}}$  are ignored for read and write cycles. These must be disabled in regions that use pipelining.

For pipelined reads, the bus controller uses a value of zero for the  $N_{\text{XDA}}$  parameter, regardless of the parameter's programmed value. A non-zero  $N_{\text{XDA}}$  value defeats the purpose of pipelining. The programmed value of  $N_{\text{XDA}}$  is used for write accesses to pipelined memory regions.

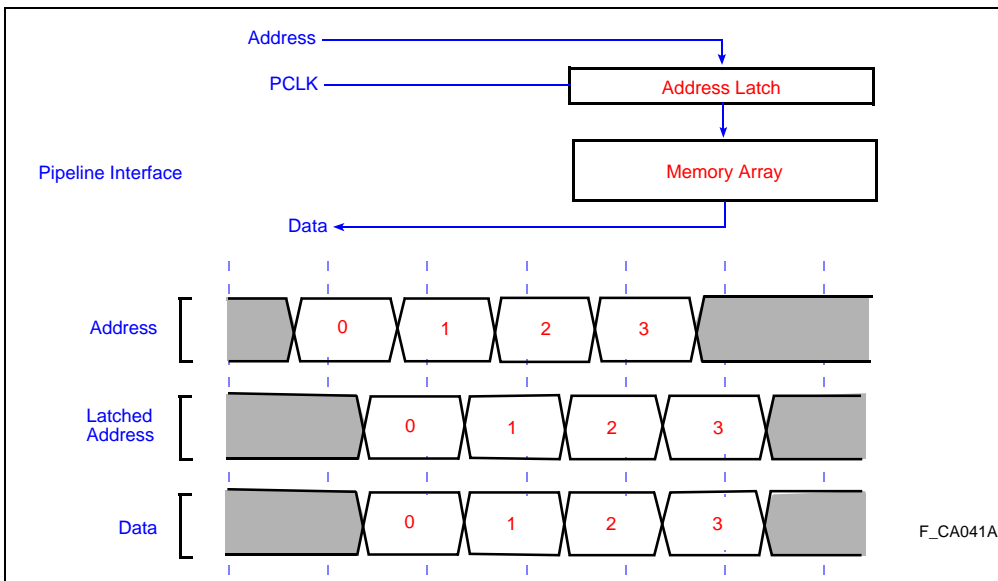


Figure 11-12. Pipelined Read Memory System

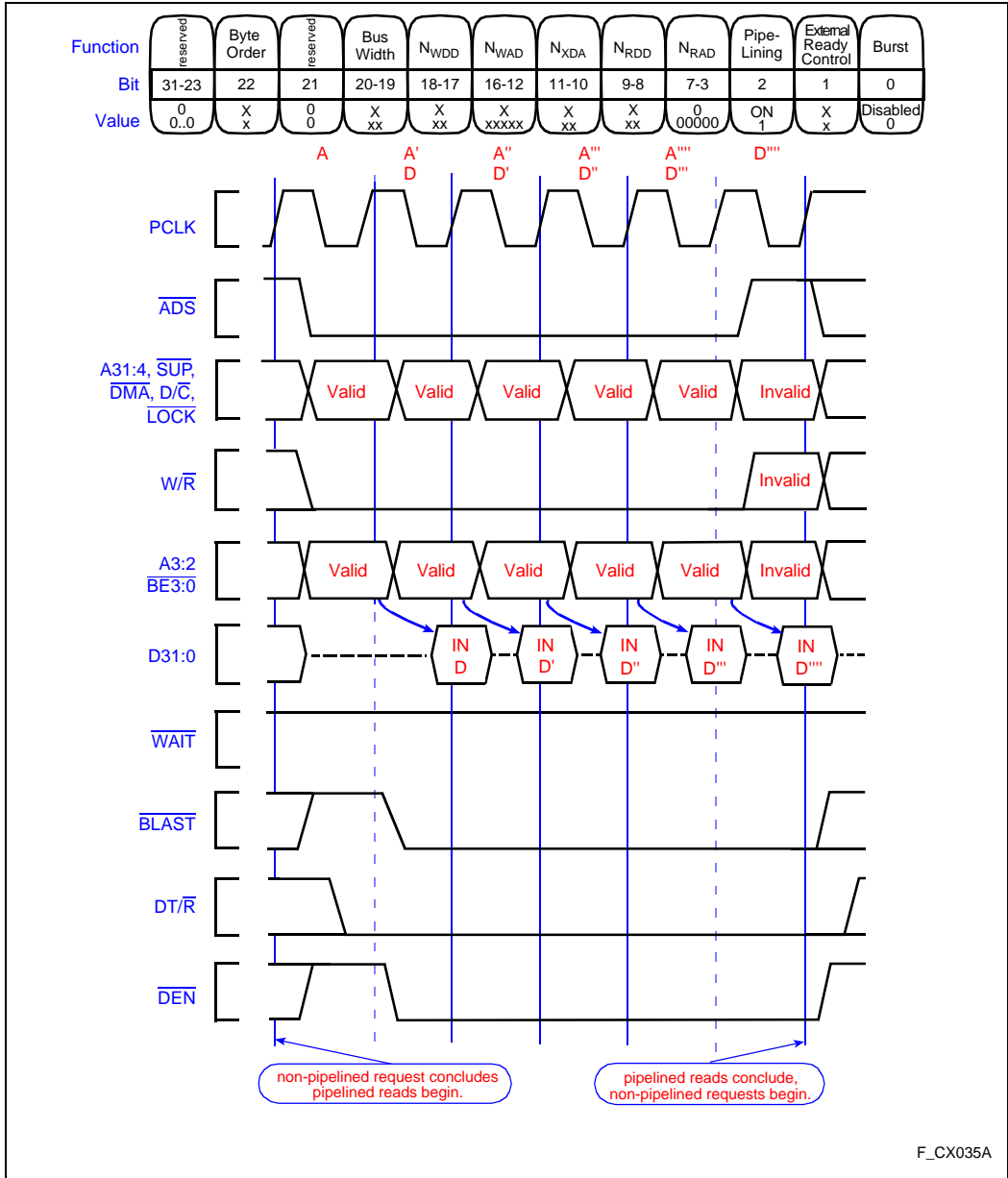


Figure 11-13. Non-Burst Pipelined Read Waveform



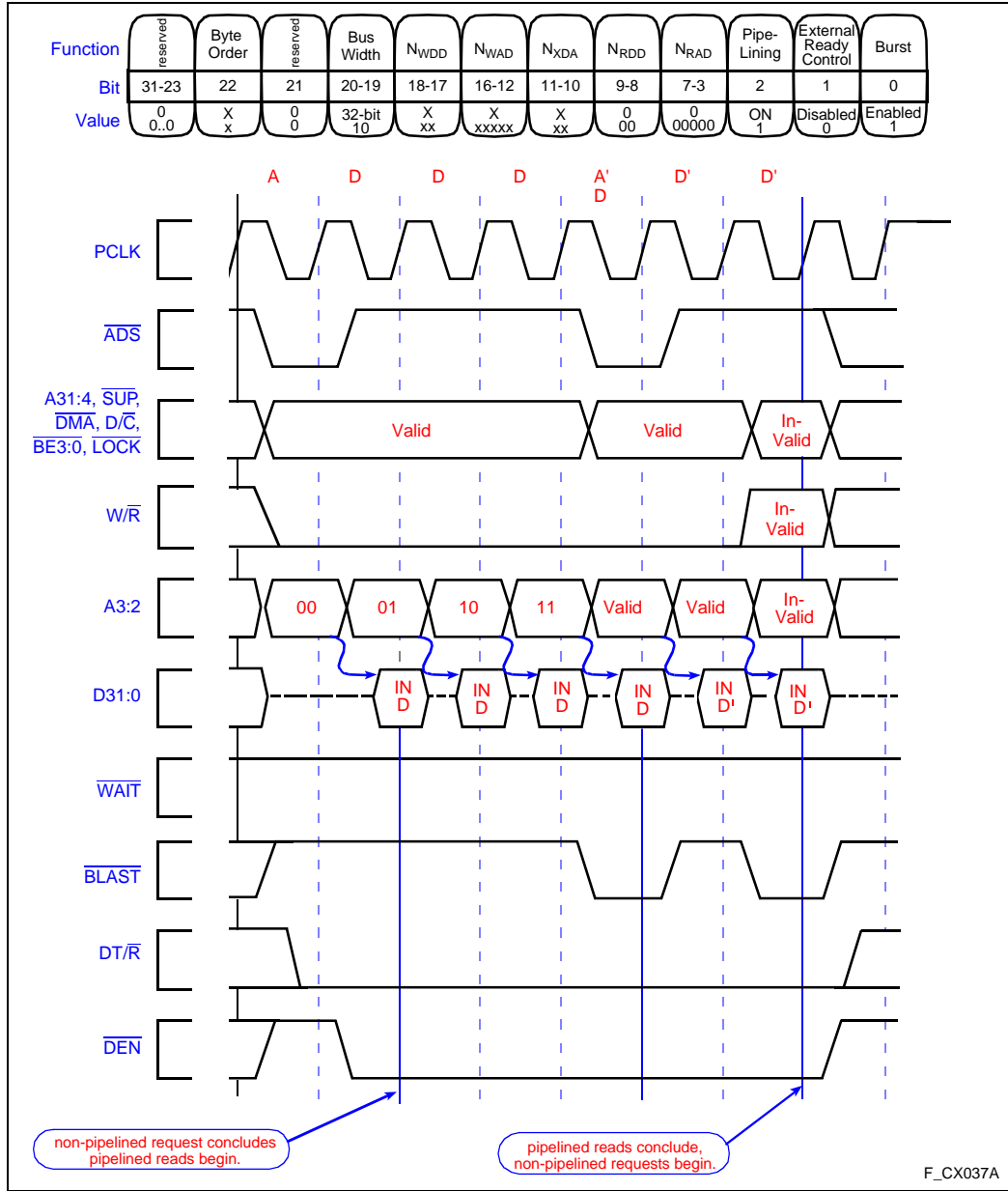


Figure 11-14. Burst Pipelined Read Waveform

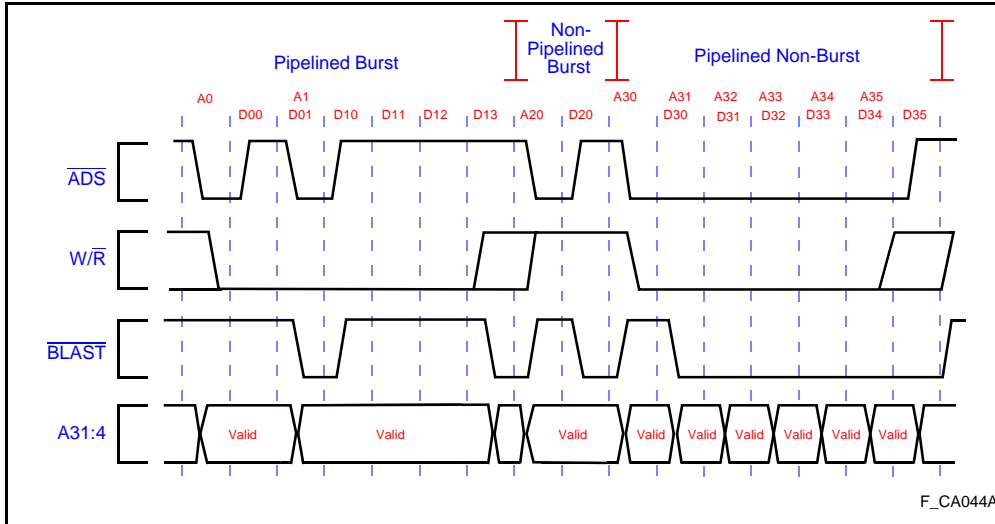


Figure 11-15. Pipelined to Non-Pipelined Transitions

### 11.3 LITTLE OR BIG ENDIAN MEMORY CONFIGURATION

The bus controller supports big endian and little endian byte ordering for memory operations. Byte ordering determines how data is read from or written to the bus and ultimately how data is stored in memory. Little endian systems store a word’s least significant byte at the lowest byte address in memory. For example, if a little endian ordered word is stored at address 600, the least significant byte is stored at address 600 and the most significant byte at address 603. Big endian systems store the least significant byte at the highest byte address in memory. So, if a big endian ordered word is stored at address 600, the least significant byte is stored at address 603 and the most significant byte at address 600.

The i960 Cx processors use little endian byte ordering internally for data-in registers and data-in internal data RAM. Data-in memory (except for internal data RAM) can be stored in either little or big endian order. A bit in the region table entry for a memory region determines the type of byte ordering used in that region. Data and instructions can be located in either big or little endian regions.

Both byte ordering methods are supported for short-word and word data types. Table 11-4 shows how a word, half-word and byte data types are transferred on the bus according to the type of byte ordering used for the selected memory region and bus width (32, 16 or 8 bits). All transfers shown in the table are aligned memory accesses.



For the word data type, assume that a hexadecimal value of aabbccddH is stored in an internal i960 Cx processor register, where aa is the word's most significant byte and dd is the least significant byte. Table 11-4 shows how this word is transferred on the bus to either a little endian or big endian region of memory.

For the half-word data type, assume that a hexadecimal value of ccddH is stored in one of the i960 Cx processors' internal registers. Note that the half-word goes out on different data lines on a 32-bit bus depending on whether address line A1 is odd or even.

Table 11-4 also shows that the i960 Cx processors handle byte data types the same regardless of byte ordering type. Multiple word bus requests (bursts) to a big endian region are handled as individual words. Bytes in each word are stored in big endian order. Big endian data types that exceed 32 bits are not supported and must be handled by software.



Table 11-4. Byte Ordering on Bus Transfers

| Word Data Type |                |      | Bus Pins (Data Lines 31:0) |       |      |     |            |       |      |     |
|----------------|----------------|------|----------------------------|-------|------|-----|------------|-------|------|-----|
| Bus Width      | Addr Bits A1:0 | Xfer | Little Endian              |       |      |     | Big Endian |       |      |     |
|                |                |      | 31:24                      | 23:16 | 15:8 | 7:0 | 31:24      | 23:16 | 15:8 | 7:0 |
| 32 bit         | 00             | 1st  | aa                         | bb    | cc   | dd  | dd         | cc    | bb   | aa  |
| 16 bit         | 00             | 1st  | --                         | --    | cc   | dd  | --         | --    | bb   | aa  |
|                | 00             | 2nd  | --                         | --    | aa   | bb  | --         | --    | dd   | cc  |
| 8 bit          | 00             | 1st  | --                         | --    | --   | dd  | --         | --    | --   | aa  |
|                | 00             | 2nd  | --                         | --    | --   | cc  | --         | --    | --   | bb  |
|                | 00             | 3rd  | --                         | --    | --   | bb  | --         | --    | --   | cc  |
|                | 00             | 4th  | --                         | --    | --   | aa  | --         | --    | --   | dd  |

| Half-Word Data Type |                |      | Bus Pins (Data Lines 31:0) |       |      |     |            |       |      |     |
|---------------------|----------------|------|----------------------------|-------|------|-----|------------|-------|------|-----|
| Bus Width           | Addr Bits A1:0 | Xfer | Little Endian              |       |      |     | Big Endian |       |      |     |
|                     |                |      | 31:24                      | 23:16 | 15:8 | 7:0 | 31:24      | 23:16 | 15:8 | 7:0 |
| 32 bit              | 00             | 1st  | --                         | --    | cc   | dd  | --         | --    | dd   | cc  |
|                     | 10             | 1st  | cc                         | dd    | --   | --  | dd         | cc    | --   | --  |
| 16 bit              | X0             | 1st  | --                         | --    | cc   | dd  | --         | --    | dd   | cc  |
| 8 bit               | X0             | 1st  | --                         | --    | --   | dd  | --         | --    | --   | cc  |
|                     |                | 2nd  | --                         | --    | --   | cc  | --         | --    | --   | dd  |

| Byte Data Type |                |      | Bus Pins (Data Lines 31:0) |       |      |     |
|----------------|----------------|------|----------------------------|-------|------|-----|
| Bus Width      | Addr Bits A1:0 | Xfer | Little and Big Endian      |       |      |     |
|                |                |      | 31:24                      | 23:16 | 15:8 | 7:0 |
| 32 bit         | 00             | 1st  | --                         | --    | --   | dd  |
|                | 01             | 1st  | --                         | --    | dd   | --  |
|                | 10             | 1st  | --                         | dd    | --   | --  |
|                | 11             | 1st  | dd                         | --    | --   | --  |
| 16 bit         | X0             | 1st  | --                         | --    | --   | dd  |
|                | X1             | 1st  | --                         | --    | dd   | --  |
| 8 bit          | XX             | 1st  | --                         | --    | --   | dd  |

11.4 ATOMIC MEMORY OPERATIONS (The  $\overline{\text{LOCK}}$  Signal)

$\overline{\text{LOCK}}$  output assertion indicates that the processor is executing an atomic read-modify-write operation. Atomic instructions (**atadd**, **atmod**) require indivisible memory access. That is, another bus agent must not access the target of the atomic instruction between read and write cycles.  $\overline{\text{LOCK}}$  can be used to implement indivisible accesses to memory.





Atomic instructions consist of a load and store request to the same memory location.  $\overline{\text{LOCK}}$  is asserted in the first address cycle of the load request and deasserted in the cycle after the last data transfer of the store request. The  $\overline{\text{LOCK}}$  pin is not active during the  $N_{\text{XDA}}$  states for the store request.

When implementing a locked memory subsystem, consider the interaction that the following mechanisms may have with the system. A system must account for these conditions during locked accesses:

- HOLD requests are acknowledged while  $\overline{\text{LOCK}}$  is asserted.
- An atomic load or store may be suspended using the  $\overline{\text{BOFF}}$  input.
- A DMA request may occur between the atomic load and store requests.

$\overline{\text{LOCK}}$  indicates that other agents should not write data to any address falling within the quad word boundary of the address on the bus when  $\overline{\text{LOCK}}$  was asserted.  $\overline{\text{LOCK}}$  is deasserted after the write portion of an atomic access. It is the responsibility of external arbitration logic to monitor the  $\overline{\text{LOCK}}$  pin and enforce its meaning for atomic memory operations. (See Figure 11-16.)

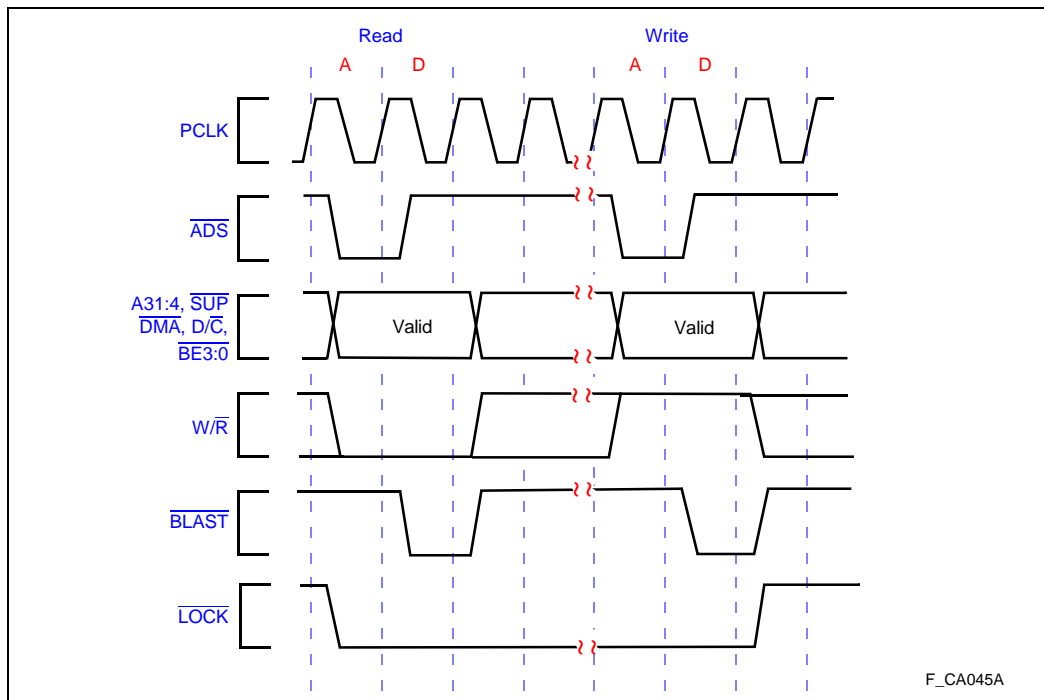


Figure 11-16. The  $\overline{\text{LOCK}}$  Signal

## 11.5 EXTERNAL BUS ARBITRATION

The i960 Cx processors provide a shared bus protocol to allow another bus master to access the processors' bus. The processor enters the hold state when an external bus master is granted bus control. In the hold state, the processors' data, address and control lines are floated (high Z) to allow the external bus master to control the bus and memory interface.

The HOLD input signal is asserted to indicate that another processor or peripheral is attempting to control the bus. The HOLDA (Hold Acknowledge) output signal acknowledges that the i960 Cx processors have relinquished the bus. Bus pins float on the same clock cycle in which the hold request is granted (HOLDA asserted). When the i960 Cx processors need to access the bus, they use the bus request signal (BREQ) to signal the other processor or peripheral.

When the HOLD signal is asserted, the i960 Cx processors grant the hold request (asserts HOLDA) and relinquishes control as follows:

- If the bus is in the idle state, the hold request is granted immediately.
- If a bus request is being serviced, the hold request is granted at the end of the current bus request.
- If the processor is in the backoff state ( $\overline{\text{BOFF}}$  pin asserted), the hold request is granted after  $\overline{\text{BOFF}}$  is deasserted and the resumed request has completed.

The hold request may be acknowledged between internal DMA load and store operations and atomic requests (read-modify-write accesses that assert  $\overline{\text{LOCK}}$ ).

When the HOLD signal is removed, HOLDA is deasserted on the following PCLK2:1 cycle and the bus and control signals are driven. The HOLD signal is a synchronous input. Setup and hold times for this input are given in the 80960CA and CF data sheets.

BREQ indicates that the bus controller queue contains one or more pending bus requests. The bus controller can queue up to three bus requests (refer to section 10.6.1, "Bus Queue" (pg. 10-14) for a complete description of the bus queue). When the bus queue is empty, the BREQ pin is deasserted. BREQ determines bus queue state during a hold state or before the hold state is requested. It may be useful to use BREQ to qualify hold requests and optimize the processor's use of the bus when shared by external masters. Because the hold request is granted between bus requests, the bus controller queue may contain one or more entries when the request is granted. BREQ can be used to delay a hold request until all pending bus requests are complete. The processor may continue executing from on-chip cache; therefore, it is possible that bus requests may be posted in the queue after the hold request is granted. In this case, BREQ can be used to relinquish the hold request when the processor needs the bus.



HOLD and HOLDA arbitration can also function during the reset state. The bus controller acknowledges HOLD while  $\overline{\text{RESET}}$  is asserted. If  $\overline{\text{RESET}}$  is asserted while HOLDA is asserted (the processor has acknowledged the HOLD), the processor remains in the HOLDA state. The processor does not go into the reset state until HOLD is removed and the processor removes HOLDA.

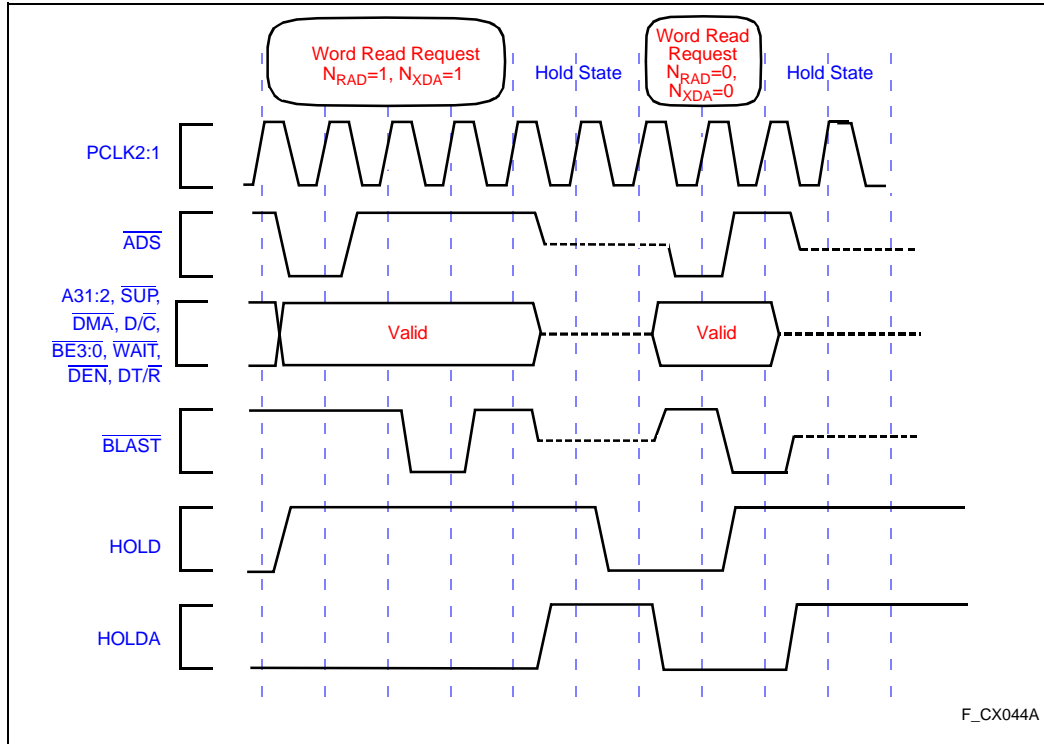


Figure 11-17. HOLD/HOLDA Bus Arbitration

11.5.1 Bus Backoff Function ( $\overline{\text{BOFF}}$  pin)

The bus backoff input ( $\overline{\text{BOFF}}$ ) suspends a bus request already in progress and allows another bus master to temporarily take control of the bus. The  $\overline{\text{BOFF}}$  pin causes the current bus request to be suspended. When  $\overline{\text{BOFF}}$  is asserted, the processor's address, data and status pins are floated on the following clock cycle. At this time, an alternate bus master may take control of the local system bus. When the alternate bus master has completed its accesses,  $\overline{\text{BOFF}}$  is deasserted and the suspended request is resumed upon assertion of  $\overline{\text{ADS}}$  on the following clock cycle. (Figure 11-18).

## EXTERNAL BUS DESCRIPTION

The backoff function differs from the bus hold mechanism. The backoff function suspends a bus request which has already started. The request is later resumed when the pin is deasserted. The bus hold mechanism allows another bus master to control the bus only after all executing bus requests have completed.

Backoff can only be used for requests to regions which have the  $\overline{\text{READY/BTERM}}$  inputs enabled, with the  $N_{\text{RAD}}$ ,  $N_{\text{RDD}}$ ,  $N_{\text{WAD}}$  and  $N_{\text{WDD}}$  parameters programmed to 0.

$\overline{\text{BOFF}}$  may only be asserted during a bus access. Recall that a bus access includes and is bounded by clock cycles in which  $\overline{\text{ADS}}$  is valid and the clock cycle in which  $\overline{\text{BLAST}}$  is valid and  $\overline{\text{READY}}$  input is asserted. External logic responsible for asserting  $\overline{\text{BOFF}}$  must ensure that the signal is not asserted during idle bus cycles or during bus turnaround ( $N_{\text{XDA}}$ ) cycles. Unpredictable behavior may occur if  $\overline{\text{BOFF}}$  is subsequently deasserted during an idle bus or turnaround cycle.

It is possible for  $\text{HOLD}$  and  $\overline{\text{BOFF}}$  to be asserted in the same clock cycle. In this case,  $\overline{\text{BOFF}}$  takes precedence. The bus is relinquished to a hold request only after the current request is complete.

Bus backoff is intended for use with special multiprocessor designs or bus architectures that do not implement “collision free” bus arbitration schemes (such as VME and MULTIBUS I). A collision occurs when multiple processors begin a bus access simultaneously and a conflict for control of one of the processor’s local memory occurs.

Figure 11-19 illustrates a bus collision. In this system, several processors share a common bus. Each processor has local memory which is connected directly to that processor’s address, data and control lines. Each processor can access another processor’s local memory over the bus.

Processor A has highest priority and Processor B has lowest priority for use of the bus. Processor A and B simultaneously request an access over the bus. Processor A attempts to access Processor B’s local memory and Processor B attempts to access another memory on the bus. Use of the bus is granted to Processor A because it is the highest priority. For Processor A to complete its access, the local bus for Processor B must be relinquished (floated). This is accomplished by asserting the  $\overline{\text{BOFF}}$  pin for Processor B.

When  $\overline{\text{BOFF}}$  is asserted, external memory is responsible for gracefully cancelling the current access. This means that the memory control state machine should cancel write cycles and return to an idle state after  $\overline{\text{BOFF}}$  is asserted. The processor ignores read data after  $\overline{\text{BOFF}}$  is asserted.



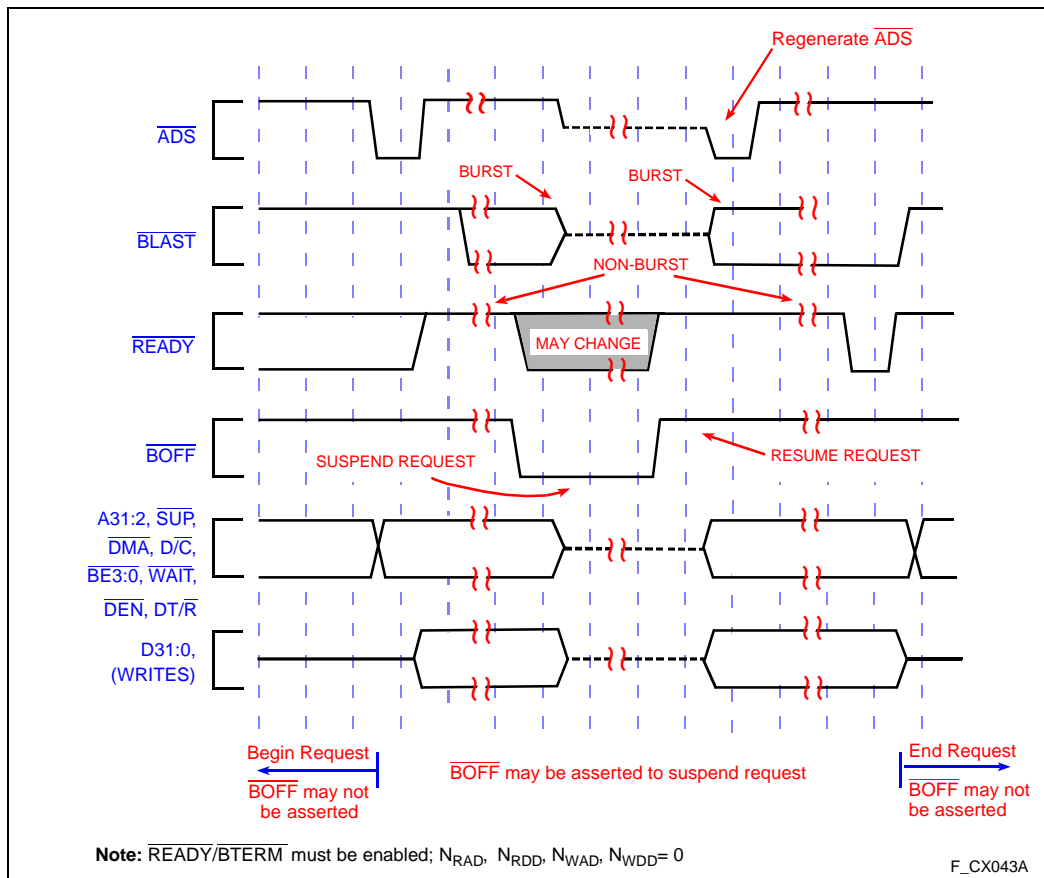


Figure 11-18. Operation of the Bus Backoff Function

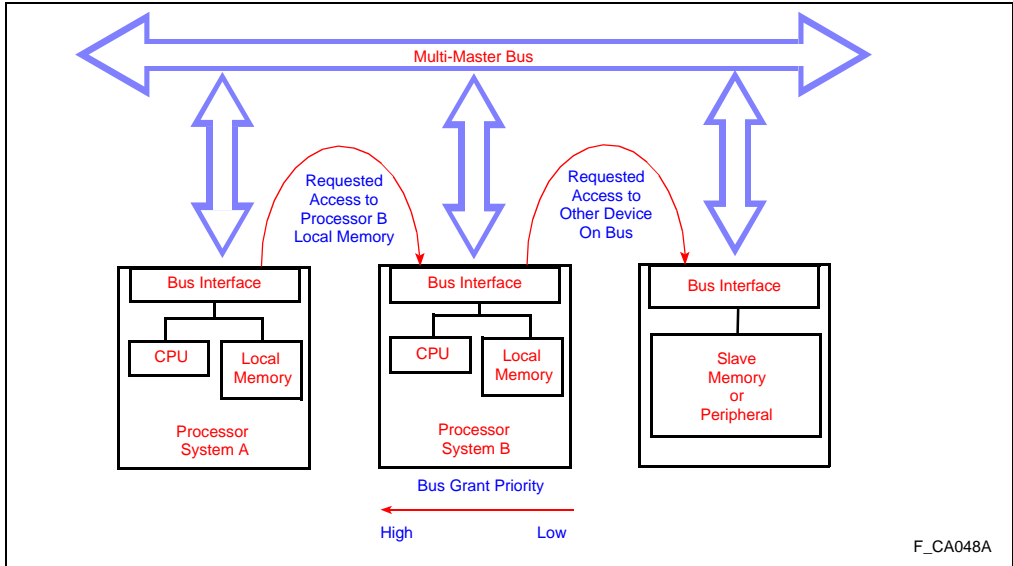


Figure 11-19. Example Application of the Bus Backoff Function



INTERRUPT CONTROLLER







## CHAPTER 12

# INTERRUPT CONTROLLER

This chapter contains interrupt controller information that is of particular importance to the system implementor. The method for handling interrupt requests from user code is described in CHAPTER 6, INTERRUPTS. Specifically, this chapter describes the i960® Cx processors' facilities for requesting and posting interrupts, the programmer's interface to the on-chip interrupt controller, implementation, latency and how to optimize interrupt performance.

### 12.1 OVERVIEW

The interrupt controller's primary functions are to provide a flexible, low-latency means for requesting and posting interrupts and to minimize the core's interrupt handling burden. The interrupt controller handles the posting of interrupts requested by hardware and software sources. The interrupt controller, acting independently from the core, compares the priorities of posted interrupts with the current process priority, off-loading this task from the core.

The interrupt controller provides the following features for managing hardware-requested interrupts:

- Low latency, high throughput handling.
- Support of up to 248 external sources.
- Eight external interrupt pins, one non-maskable interrupt pin, four internal DMA sources for detection of hardware-requested interrupts.
- Edge or level detection on external interrupt pins.
- Debounce option on external interrupt pins.

The user program interfaces to the interrupt controller with four control registers and two special function registers. The interrupt control register (ICON) and interrupt map control registers (IMAP0-IMAP2) provide configuration information. The interrupt pending (IPND) special function register posts hardware-requested interrupts. The interrupt mask (IMSK) special function register selectively masks hardware-requested interrupts.

## 12.2 MANAGING INTERRUPT REQUESTS

The i960 processor architecture provides a consistent interrupt model, as required for interrupt handler compatibility between various implementations of the i960 processor family. The architecture, however, leaves the interrupt request management strategy to the specific i960 processor family implementations. In the i960 Cx processors, the programmable on-chip interrupt controller transparently manages all interrupt requests (Figure 12-1). These requests originate from:

- 8-bit external interrupt pins  $\overline{XINT7:0}$
- four DMA controller channels
- non-maskable interrupt pin  $\overline{NMI}$
- **sysctl** instruction execution

External interrupt pins can be programmed to operate in three modes:

1. dedicated mode: the pins may be individually mapped to interrupt vectors.
2. expanded mode: the pins may be interpreted as a bit field which can request any of the 248 possible interrupts that the i960 processor family supports.
3. mixed mode: five pins operate in expanded mode and can request thirty-two different interrupts, and three pins operate in dedicated mode.

Dedicated-mode requests are posted in the Interrupt Pending Register (IPND). The processor does not post expanded-mode requests.

The  $\overline{NMI}$  pin allows a highest-priority, non-maskable and non-interruptible interrupt to be requested.  $\overline{NMI}$  is always a dedicated-mode input.

Each of the four DMA channels has an associated interrupt request to allow the application to synchronize with the DMA operations of each channel. DMA interrupt requests are always handled as dedicated-mode interrupt requests.

The application program may use the **sysctl** instruction to request interrupt service. The vector that **sysctl** requests is serviced immediately or posted in the interrupt table's pending interrupts section, depending upon the current processor priority and the request's priority. The interrupt controller caches the priority of the highest priority interrupt posted in the interrupt table.

The interrupt controller continuously compares the priorities of the highest-posted software interrupt and the highest-pending hardware interrupt to the processor's priority. The core is interrupted when a pending interrupt request is higher than the processor priority or a priority 31. In the event that both hardware- and software-requested interrupts are posted at the same level, the hardware interrupt is serviced before the software interrupt, when the priority is 1 to 30. At priority 31, the software interrupt is serviced first.



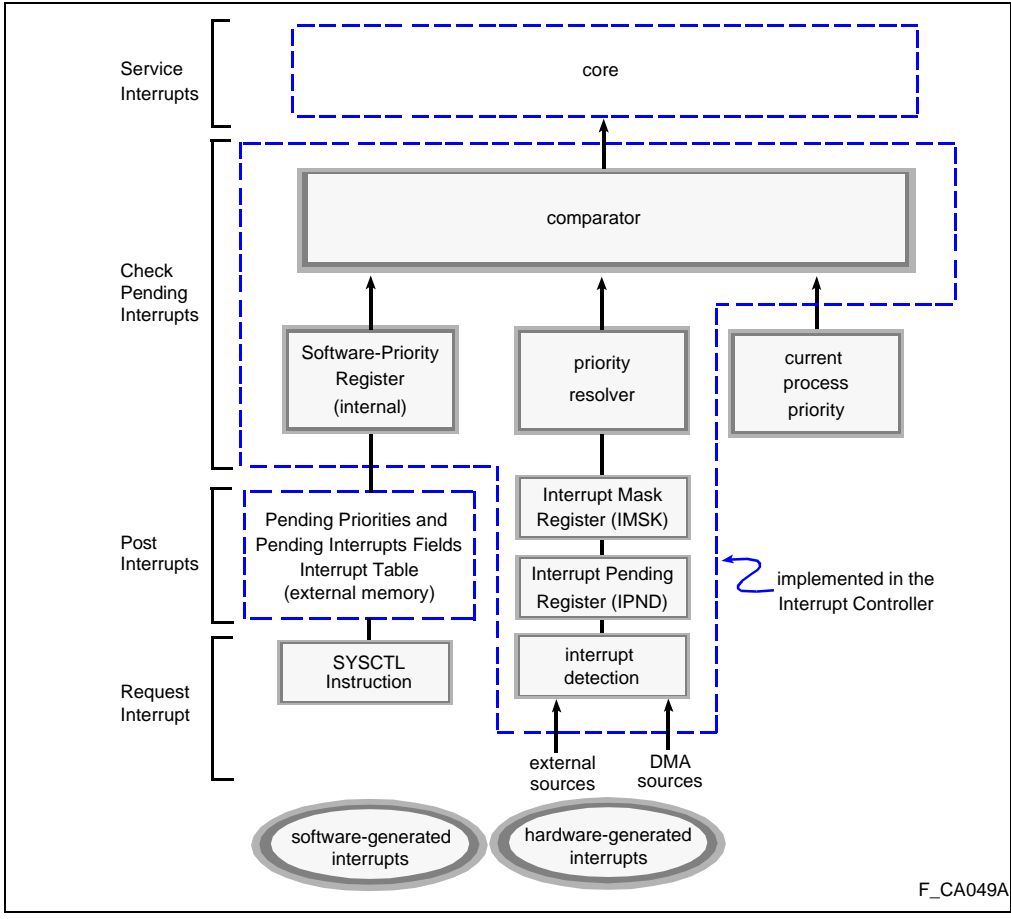


Figure 12-1. Interrupt Controller

12.2.1 Interrupt Controller Modes

The eight external interrupt pins can be configured for one of three modes: expanded, dedicated and mixed. Each mode is described in the subsections that follow.



12.2.1.1 Dedicated Mode

In dedicated mode, each external interrupt pin is assigned a vector number. Vector numbers that may be assigned to a pin are those with the encoding PPPP 0010<sub>2</sub> (Figure 12-2), where bits marked P are programmed with bits in the interrupt map (IMAP) registers. This encoding of programmable bits and preset bits can designate 15 unique vector numbers, each with a unique, even-numbered priority. (Vector 0000 0010<sub>2</sub> is undefined; it has a priority of 0.)

Dedicated-mode interrupts are posted in the interrupt pending (IPND) register. Single bits in the IPND register correspond to each of the eight dedicated external interrupt inputs, plus the four DMA inputs to the interrupt controller. The interrupt mask (IMSK) register selectively masks each of the dedicated-mode interrupts. The IMSK register can optionally be saved and cleared when a dedicated interrupt is serviced. This allows other hardware-generated interrupts to be locked out until the mask is restored. See section 12.3.3, “Programmer’s Interface” (pg. 12-11) for a further description of the IMSK, IPND and IMAP registers.

Interrupt vectors are assigned to DMA inputs in the same way external pins are assigned dedicated-mode vectors. The DMA interrupts are always dedicated-mode interrupts.

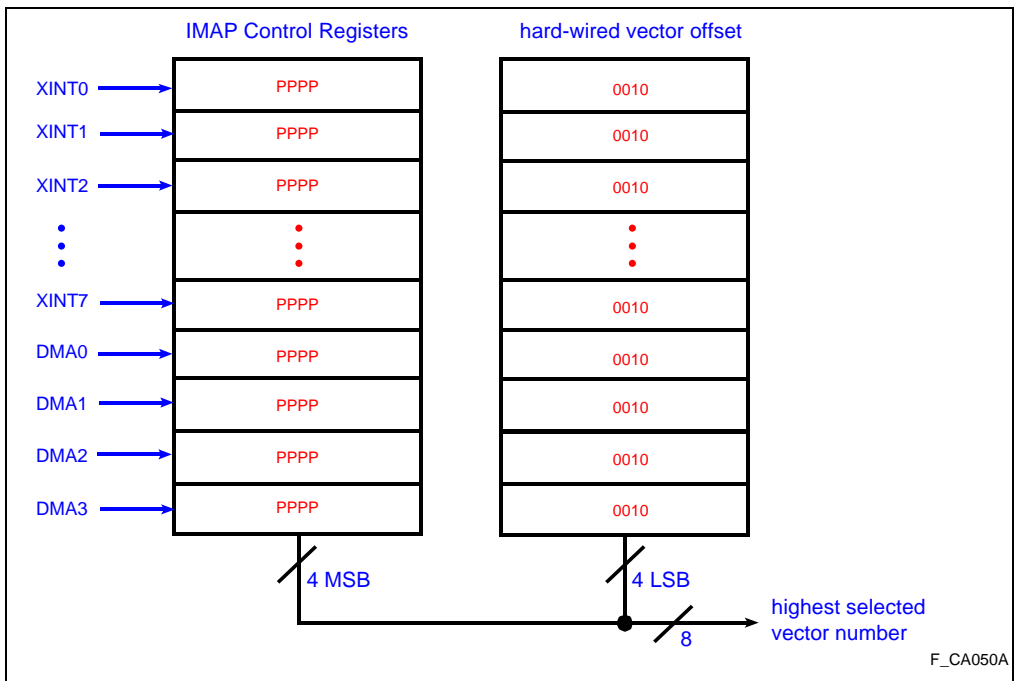


Figure 12-2. Dedicated Mode



12.2.1.2 Expanded Mode

In expanded mode, up to 248 interrupts can be requested from external sources. Multiple external sources are externally encoded into the 8-bit interrupt vector number. This vector number is then applied to the external interrupt pins (Figure 12-3), with the  $\overline{XINT0}$  pin representing the least-significant bit and  $\overline{XINT7}$  the most significant bit of the number. Note that external interrupt pins are active low; therefore, the inverse of the vector number is actually applied to the pins.

In expanded mode, external logic is responsible for posting and prioritizing external sources. Typically, this scheme is implemented with a simple configuration of external priority encoders. As shown in Figure 12-4 simple, combinational logic can handle prioritization of the external sources when more than one expanded interrupt is pending.

**NOTE:**

The interrupt source, as shown in Figure 12-4, must remain asserted until the processor services the interrupt and explicitly clears the source. External-interrupt pins in expanded mode are always active low and level-detect.

The interrupt controller ignores vector numbers 0 though 7. The output of the external priority encoders in Figure 12-4 can use the 0 vector to indicate that no external interrupts are pending.

IMSK register bit 0 provides a global mask for all expanded interrupts. The remaining bits (1-7) should be set to 0 in expanded mode. The mask bit can optionally be saved and cleared when an expanded mode interrupt is serviced. This allows other hardware-requested interrupts to be locked out until the mask is restored. IPND register bits 0-7, in expanded mode, have no function since external logic is responsible for posting interrupts.

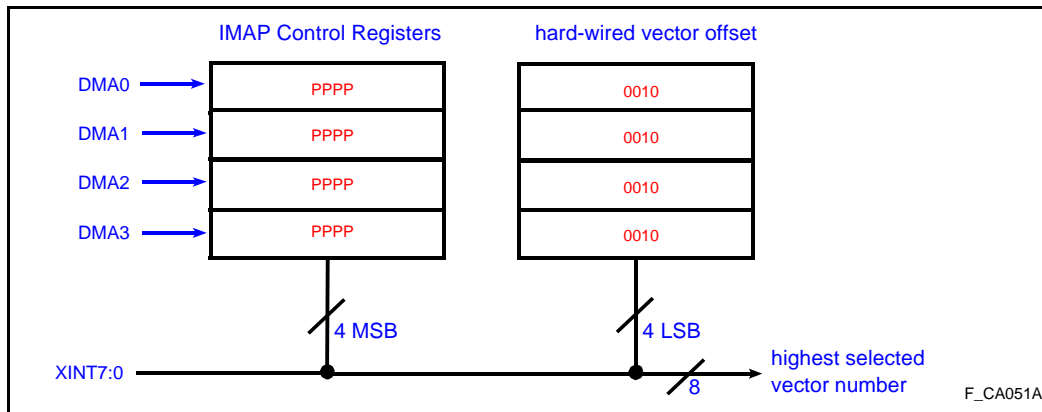


Figure 12-3. Expanded Mode

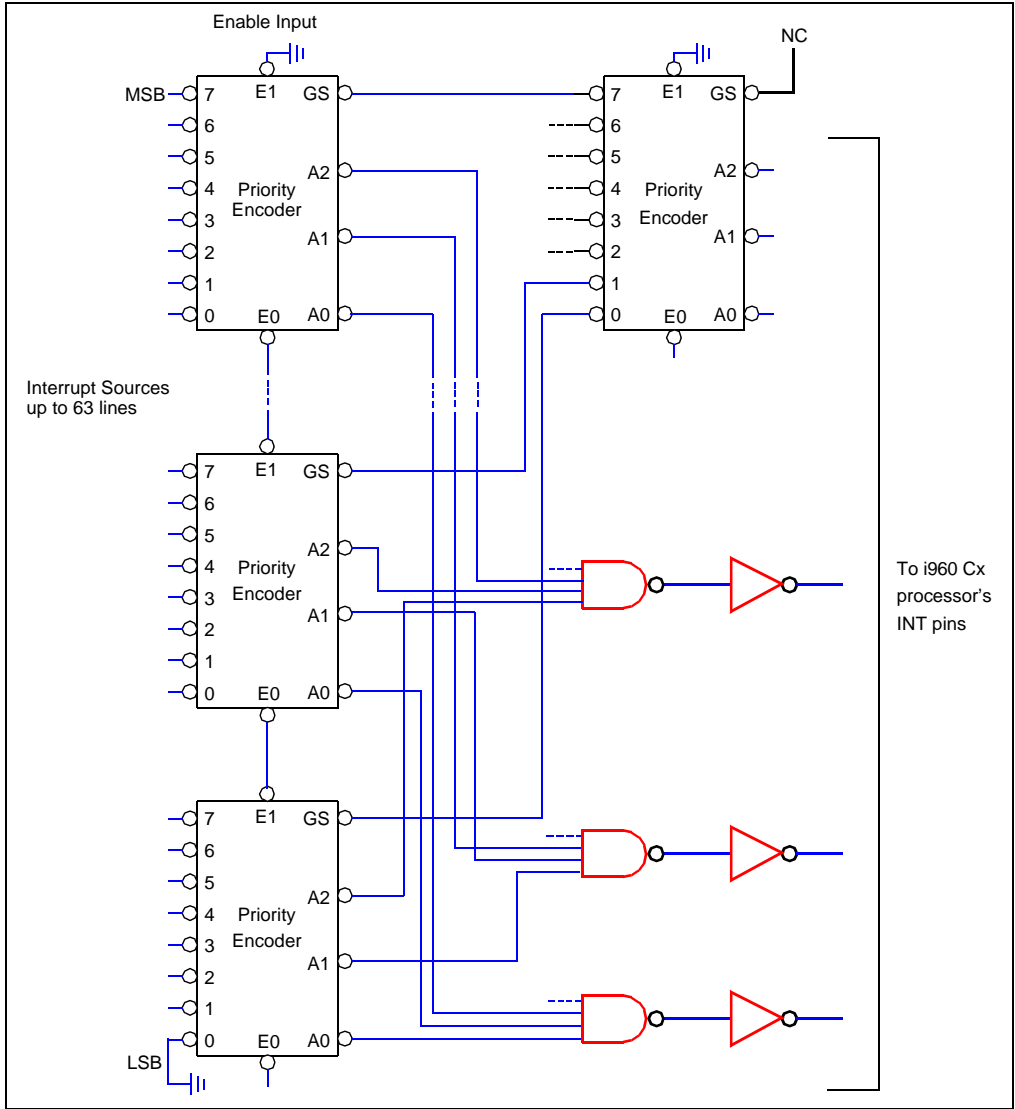


Figure 12-4. Implementation of Expanded Mode Sources



### 12.2.1.3 Mixed Mode

In mixed mode, pins  $\overline{\text{XINT0}}$  through  $\overline{\text{XINT4}}$  are configured for expanded mode. These pins are encoded for the five most-significant bits of an expanded-mode vector number; the three least-significant bits of the vector number are set internally to be 010<sub>2</sub>. Pins  $\overline{\text{XINT5}}$  through  $\overline{\text{XINT7}}$  are configured for dedicated mode.

IMSK register bit 0 is a global mask for the expanded-mode interrupts; bits 5 through 7 mask the dedicated interrupts from pins  $\overline{\text{XINT5}}$  through  $\overline{\text{XINT7}}$ , respectively. IMSK register bits 1-4 must be set to 0 in mixed mode. The IPND register posts interrupts from the dedicated-mode pins  $\overline{\text{XINT7:5}}$ . IPND register bits that correspond to expanded-mode inputs are not used.

#### CAUTION

When setting IMSK register bits in mixed mode, make sure IMSK register bits 1-4 are set to 0.

### 12.2.2 Non-Maskable Interrupt (NMI)

The  $\overline{\text{NMI}}$  pin generates an interrupt for implementation of critical interrupt routines.  $\overline{\text{NMI}}$  provides an interrupt that cannot be masked and that has a higher priority than priority-31 interrupts and priority-31 process priority. The interrupt vector for  $\overline{\text{NMI}}$  resides in the interrupt table as vector number 248. During initialization, the core caches the vector for  $\overline{\text{NMI}}$  on-chip, to reduce  $\overline{\text{NMI}}$  latency. The  $\overline{\text{NMI}}$  vector is cached in location 0H of internal data RAM.

The core immediately services  $\overline{\text{NMI}}$  requests. While servicing  $\overline{\text{NMI}}$ , the core does not respond to any other interrupt requests — even another  $\overline{\text{NMI}}$  request — until it returns from the  $\overline{\text{NMI}}$  handling procedure. An interrupt request on the  $\overline{\text{NMI}}$  pin is always falling-edge detected.

### 12.2.3 Saving the Interrupt Mask

The IMSK register is automatically saved in register r3 when a hardware-requested interrupt is serviced. After the mask is saved, the IMSK register is optionally cleared. This allows all interrupts except  $\overline{\text{NMIs}}$  to be masked while an interrupt is being serviced. Since the IMSK register value is saved, the interrupt procedure can restore the value before returning. The option of clearing the mask is selected by programming the ICON register as described in section 12.3.4, “Interrupt Control Register (ICON)” (pg. 12-11). Several options are provided for interrupt mask handling:

1. Mask is unchanged.
2. Clear for dedicated-mode sources only.
3. Clear for expanded-mode sources only.
4. Clear for all hardware-requested interrupts (dedicated and expanded mode).

## INTERRUPT CONTROLLER

Options 2 and 3 are used in mixed mode, where both dedicated-mode and expanded-mode inputs are allowed. DMA interrupts are always dedicated-mode interrupts.

### NOTE:

If the same interrupt is requested simultaneously by a dedicated- and an expanded-mode source, the interrupt is considered an expanded-mode interrupt and the IMSK register is handled accordingly.

The IMSK register must be saved and cleared when expanded mode inputs request a priority-31 interrupt. Priority-31 interrupts are interrupted by other priority-31 interrupts. In expanded mode, the interrupt pins are level-activated. For level-activated interrupt inputs, instructions within the interrupt handler are typically responsible for causing the source to deactivate. If these priority-31 interrupts are not masked, another priority-31 interrupt will be signaled and serviced before the handler is able to deactivate the source. The first instruction of the interrupt handling procedure is never reached, unless the option is selected to clear the IMSK register on entry to the interrupt.

Another use of the mask is to lock out other interrupts when executing time-critical portions of an interrupt handling procedure. All hardware-generated interrupts are masked until software explicitly replaces the mask.

The processor does not restore r3 to the IMSK register when the interrupt return is executed. If the IMSK register is cleared, the interrupt handler must restore the IMSK register to enable interrupts after return from the handler.

### 12.3 EXTERNAL INTERFACE DESCRIPTION

This section describes the physical characteristics of the interrupt inputs. The i960 Cx processors provide eight external interrupt pins and one non-maskable interrupt pin for detecting external interrupt requests. The eight external pins can be configured as dedicated inputs, where each pin is capable of requesting a single interrupt. The external pins can also be configured in an expanded mode, where the value asserted on the external pins represents an interrupt vector number. In this mode, up to 248 values can be directly requested with the interrupt pins. The external interrupt pins can be configured in mixed mode. In this mode, some pins are dedicated inputs and the remaining pins are used in expanded mode.





### 12.3.1 Pin Descriptions

The interrupt controller provides nine interrupt pins:

|                             |  |
|-----------------------------|--|
| $\overline{\text{XINT7:0}}$ | External Interrupt (input) - These eight pins cause interrupts to be requested. Pins are software configurable for three modes: dedicated, expanded, mixed. Each pin can be programmed as an edge- or level-detect input. Also, a debounce sampling mode for these pins can be selected under program control.     |
| $\overline{\text{NMI}}$     | Non-Maskable Interrupt (input) - This edge-activated pin causes a non-maskable interrupt event to occur. $\overline{\text{NMI}}$ is the highest priority interrupt recognized. A debounce sampling mode for $\overline{\text{NMI}}$ can be selected under program control. These pins are internally synchronized. |

### 12.3.2 Interrupt Detection Options

The  $\overline{\text{XINT7:0}}$  pins can be programmed for level-low or falling-edge detection when used as dedicated inputs. All dedicated inputs plus the  $\overline{\text{NMI}}$  pin are programmed (globally) for fast sampling or debounce sampling. Expanded-mode inputs are always sampled in debounce mode. Pin detection and sampling options are selected by programming the ICON register.

- When a pin is programmed for falling-edge detection, the corresponding pending bit in the IPND register is set when a high-to-low transition is detected.
- When a pin is programmed for low-level detection, the corresponding pending bit in the IPND register is set when a low-level is detected.

Even for the level detect mode, the pending bits are “sticky” and remain set after the interrupt source removes the active level from the interrupt pin.

The processor attempts to clear the pending bit on entry into the interrupt handler. Edge- and level-detect modes are distinguished by the way software must deal with the external interrupt source on entry into the handler.

- For the edge-detect mode, the pending bit is cleared when the handler is entered. In this mode, software is not required to clear the interrupt source.
- In the level-detect mode, the pending bit remains set if the external source is still active. This means that software must explicitly clear the interrupt source before returning from the interrupt handler. Otherwise, the handler is re-entered after the return is executed.

Example 12-1 demonstrates how a level detect interrupt is typically handled. The example assumes that the **ld** from address “timer\_0,” deactivates the interrupt input.

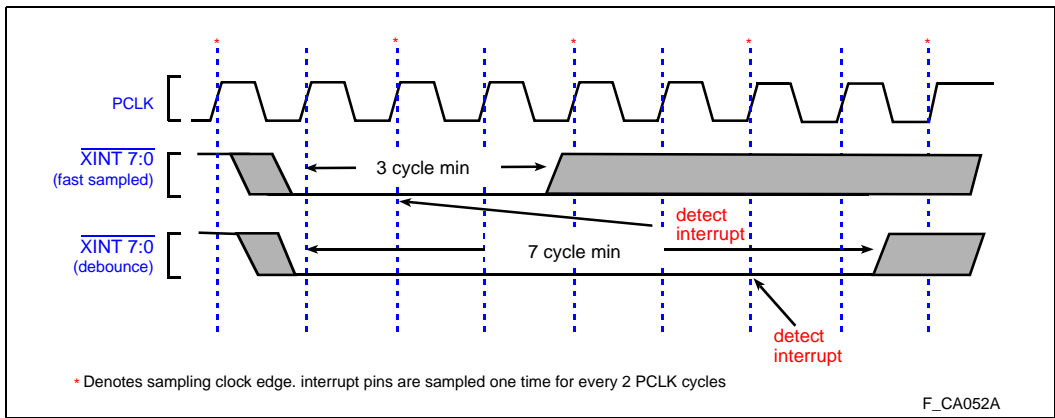
**Example 12-1. Return from a Level-detect Interrupt**

```
# Clear level-detect interrupts before return from handler
ld timer_0, g0 # Get timer value and clear XINT0
wait:
clrbit 0,sf0,sf0 # Attempt to clear bit
bbs 0,sf0,wait # Retry if not clear
ret # Return from handler
```

The debounce sampling mode provides a built-in filter for noisy or slow-falling inputs. The debounce sampling mode requires that a low level is stable for approximately 6 PCLK2:1 periods before the interrupt input is detected. Expanded mode interrupts are always sampled using the debounce sampling mode. This mode provides time for interrupts to trickle through external priority encoders.

Figure 12-5 shows how a signal is detected in each mode debounce and fast sample mode. The debounce-sampling option adds several clocks to an interrupt’s latency due to the multiple clocks of sampling. Interrupt pins are asynchronous inputs and are synchronized internally by the processor. If the input width is sufficient, the input is detected correctly regardless of setup and hold time relative to PCLK2:1.

The interrupt inputs are internally sampled once every two PCLK2:1 falling edges. Setup and hold specifications are provided in the data sheet which guarantee detection of the interrupt on particular edges of PCLK2:1. These specification are useful in designs which use synchronous logic to generate interrupt signals to the processor. These specification must also be used to calculate the minimum signal width, as shown in Figure 12-5.



**Figure 12-5. Interrupt Sampling**

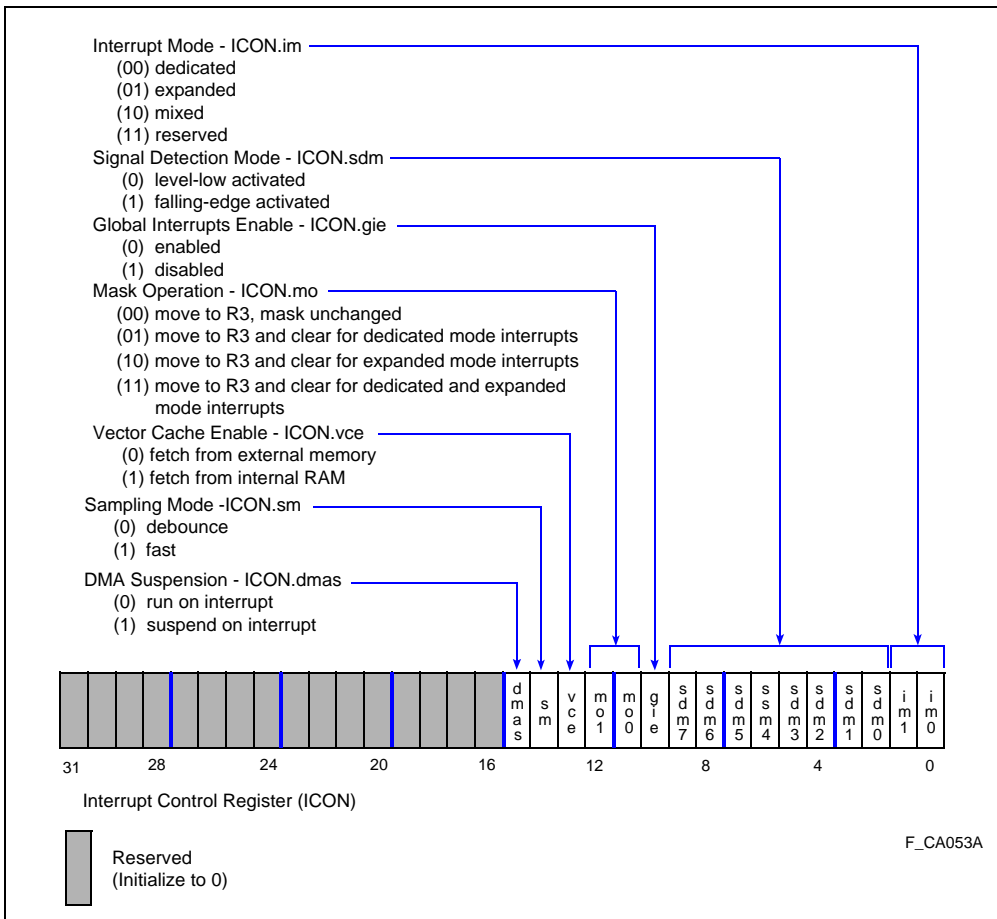


### 12.3.3 Programmer's Interface

The programmer's interface to the interrupt controller is through four control registers and two special function registers (all described in this section): ICON control register, IMAP0-IMAP2 control registers, IMSK special-function register (sf1) and IPND special function register(sf0).

### 12.3.4 Interrupt Control Register (ICON)

The ICON register (Figure 12-6) is a 32-bit control register that sets up the interrupt controller. Software can load this register using the **sysctl** instruction. The ICON register is also automatically loaded at initialization from the control table in external memory.



Errata (12-06-94 SRB)  
 Vector Cache Enable bits (ICON.vce) incorrectly defined.  
 Bit 0 was "debounce"; it now is correctly defined as "Fetch From External Memory".  
 Bit 1 was "Fast"; is now correctly defined as "Fetch From Internal RAM".

Figure 12-6. Interrupt Control (ICON) Register

## INTERRUPT CONTROLLER

The *interrupt mode field* (bits 0 and 1) determines the operation mode for the external interrupt pins ( $\overline{XINT7:0}$ ) — dedicated, expanded or mixed.

The *signal-detection-mode bits* (bits 2 - 9) determine whether the signals on the individual external interrupt pins ( $\overline{XINT7:0}$ ) are level-low activated or falling-edge activated. Expanded-mode inputs are always level-detected; the  $\overline{NMI}$  input is always edge-detected — regardless of the bit's value.

The *global-interrupts enable bit* (bit 10) globally enables or disables the external interrupt pins and DMA inputs. It does not affect the  $\overline{NMI}$  pin. This bit performs the same function as clearing the mask register.

The *mask-operation field* (bits 11, 12) determines the operation the core performs on the mask register when a hardware-generated interrupt is serviced. On an interrupt, the IMASK register is either unchanged; cleared for dedicated-mode interrupts; cleared for expanded-mode interrupts; or cleared for both dedicated- and expanded-mode interrupts.

The *vector cache enable bit* (bit 13) determines whether interrupt table vector entries are fetched from the interrupt table or from internal data RAM. Only vectors with four least-significant bits equal to  $0010_2$  may be cached in internal data RAM.

The *sampling-mode bit* (bit 14) determines whether dedicated inputs and  $\overline{NMI}$  pin are sampled using debounce sampling or fast sampling. Expanded-mode inputs are always detected using debounce mode.

The *DMA-suspension bit* (bit 15) determines whether DMA continues running or is suspended while an interrupt procedure is being called.

Bits 16 through 31 are reserved and must be set to 0 at initialization.

### 12.3.5 Interrupt Mapping Registers (IMAP0-IMAP2)

The IMAP registers (Figure 12-7) are three 32-bit registers (IMAP0 through IMAP2). These register's bits are used to program the vector number associated with the interrupt source when the source is connected to a dedicated-mode input. IMAP0 and IMAP1 contain mapping information for the external interrupt pins (four bits per pin); IMAP2 contains mapping information for the DMA-interrupt inputs (four bits per input).

Each set of four bits contains a vector number's four most-significant bits; the four least-significant bits are always  $0010_2$ . In other words, each source can be programmed for a vector number of PPPP  $0010_2$ , where "P" indicates a programmable bit. For example, IMAP0 bits 4 through 7 contain mapping information for the XINT1 pin. If these bits are set to  $0110_2$ , the pin is mapped to vector number  $0110\ 0010_2$  (or vector number 98).



Software can load the mapping registers using the **sysctl** instruction. The mapping registers are also automatically loaded at initialization from the control table in external memory. Note that bits 16 through 31 of each register are reserved and should be set to 0 at initialization.

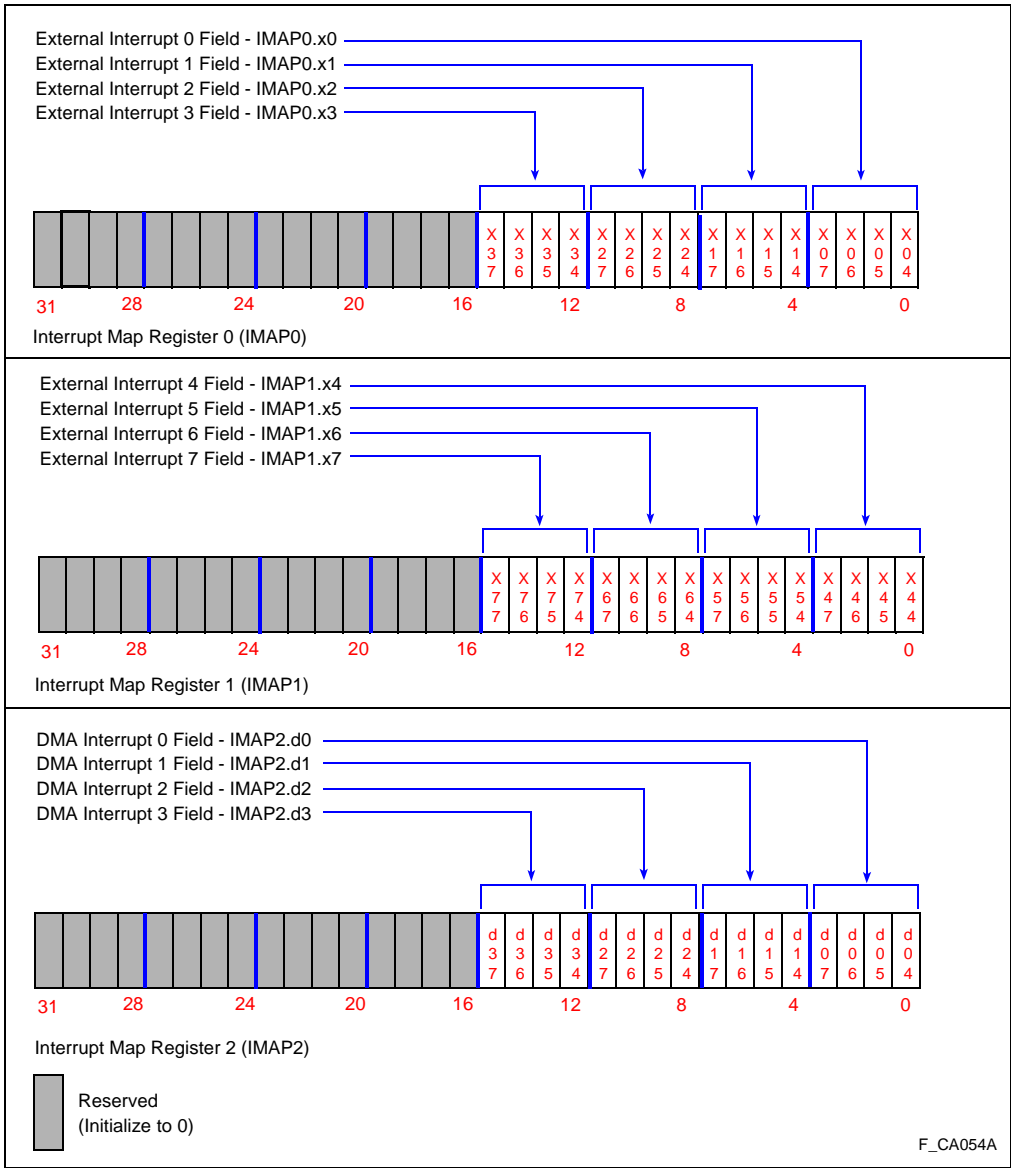


Figure 12-7. Interrupt Mapping (IMAP0-IMAP2) Registers

### 12.3.6 Interrupt Mask and Pending Registers (IMSK, IPND)

The IMSK and IPND registers (Figure 12-8) are special-function registers (sf1 and sf0, respectively). Bits 0 through 7 of these registers are associated with the external interrupt pins ( $\overline{XINT7:0}$ ) and bits 8 through 11 are associated with the DMA-interrupt inputs (DMA3:0). Bits 12 through 31 are reserved and should be set to 0 at initialization.

The IPND register posts dedicated-mode interrupts originating from the eight external dedicated sources (when configured in dedicated mode) and the four DMA sources. Asserting one of these inputs causes a 1 to be latched into its associated bit in the IPND register. In expanded mode, bits 0 through 7 of this register are not used and should not be modified; in mixed mode, bits 0 through 4 are not used and should not be modified.

The IMSK register provides a mechanism for masking individual bits in the IPND register. An interrupt source is disabled if its associated mask bit is set to 0.

IMSK register bit 0 has two functions: it masks interrupt pin  $\overline{XINT0}$  in the dedicated mode and it globally masks all expanded-mode interrupts in the expanded and mixed modes. In expanded mode, bits 1 through 7 are not used and should only contain zeros; in mixed mode, bits 1 through 4 are not used and should only contain zeros.

Software can read and write the IPND and IMSK registers, using any instruction that can use special-function registers as operands.

When the core handles a pending interrupt, it attempts to clear the bit that is latched for that interrupt in the IPND register before it begins servicing the interrupt. If that bit is associated with an interrupt source that is programmed for level detection and the true level is still present, the bit remains set. Because of this, the interrupt routine for a level-detected interrupt should clear the external interrupt source and explicitly clear the IPND bit before return from handler is executed.

An alternative method of posting interrupts in the IPND register (other than through the external interrupt pins and DMA-interrupt inputs) is to set bits in the register directly using an instruction — such as a move instruction. This operation has the same effect as requesting an interrupt through the external interrupt pins or DMA-interrupt inputs. The bit set in the IPND register must be associated with an interrupt source that is programmed for dedicated-mode operation.



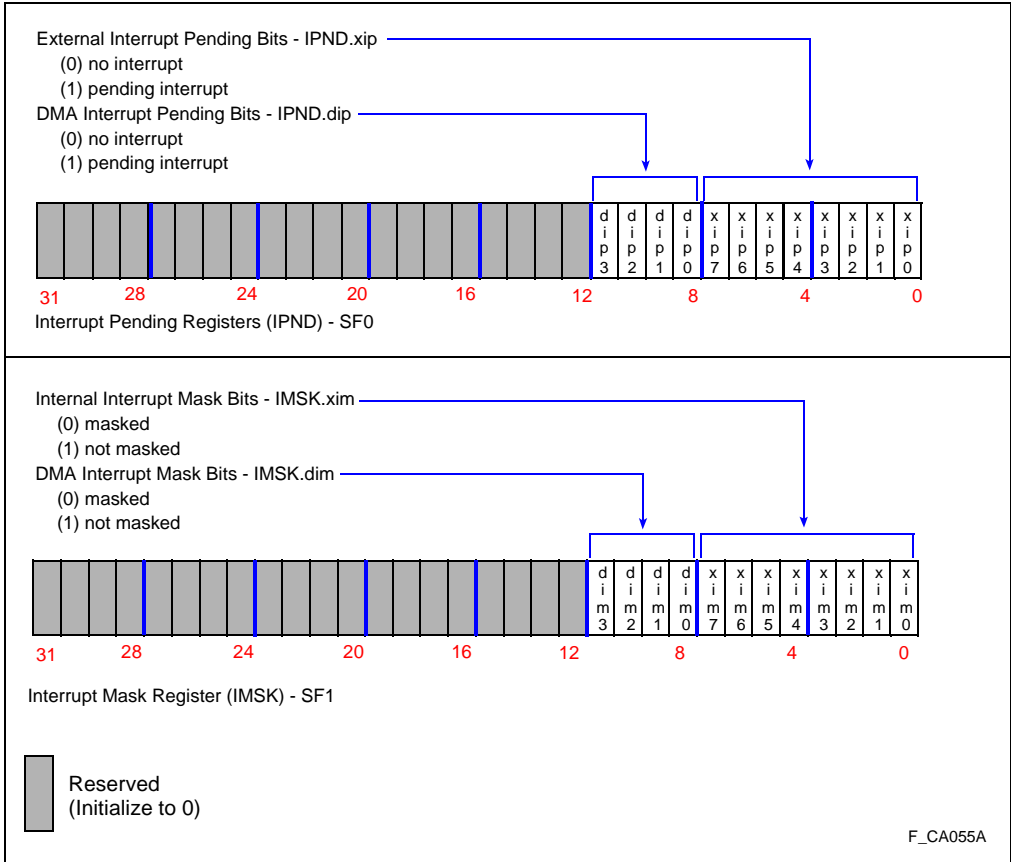


Figure 12-8. Interrupt Mask (IMSK) and Interrupt Pending (IPND) Registers

### 12.3.7 Default and Reset Register Values

The ICON and IMAP2:0 control registers are loaded from the control table in external memory when the processor is initialized or reinitialized. The control table is described in section 2.3, “CONTROL REGISTERS” (pg. 2-6). The IMSK register is set to 0 when the processor is initialized ( $\overline{\text{RESET}}$  is deasserted). The IPND register value is undefined after a power-up initialization (cold reset). The user is responsible for clearing this register before any mask register bits are set; otherwise, unwanted interrupts may be triggered. For a reset while power is ON (warm reset), the pending register value is retained.

### 12.3.8 Setting Up the Interrupt Controller

This section provides several examples of setting up the interrupt controller. Recall that the IMAP and ICON registers are control registers. When the entire control table is automatically read at initialization, the ICON and IMAP registers are loaded with the values pre-programmed in the table. In many applications, setting these register values in the initial control table is the only setup required. The following examples describe how the interrupt controller can be dynamically configured after initialization.

Example 12-2 sets up the interrupt controller for expanded-mode operation. Here, a value which selects expanded-mode operation is loaded into the ICON register. The **sysctl** instruction is issued with the load-control register message type (04H) and selecting group number 01H from the control table. Group 01H contains the ICON and IMAP registers. Note that the IMAP registers, as well as the ICON register, are reloaded with this operation.

Modifying the control table implies that the table (or part of it) must reside in RAM. If the control registers are modified after initialization, the control register must be relocated to RAM by reinitializing. See section 14.3.1, “Reinitializing and Relocating Data Structures” (pg. 14-11).

**Example 12-2. Programming the Interrupt Controller for Expanded Mode**

```
# Example expanded mode setup . . .
mov      0,sf1
ldconst  0x01, g0          # clear IMSK register
                                # (mask all interrupts)
st       g0,ctrl_table_ICON # store mode information to
                                # control table
ldconst  0x401,r4         # create operand for sysctl,
                                # selects load control
                                # register message type,
                                # selects register group 1
sysctl   r4, r4, r4       # load control register
mov      1,sf1           # unmask expanded interrupts
```

### 12.3.9 Implementation

The interrupt controller, microcode and core resources handle all stages of interrupt service. Interrupt service is handled in the following stages:

**Requesting Interrupts** — In the i960 Cx processors, the programmable on-chip interrupt controller transparently manages all interrupt requests. Interrupts are generated by hardware (external events) or software (the user program). Hardware requests are signaled on the 8-bit external interrupt port XINT7:0, the non-maskable interrupt pin NMI or the four DMA controller channels. Software interrupts are signaled with the **sysctl** instruction with post-interrupt message type.





**Posting Interrupts** — When an interrupt is requested, the interrupt is either serviced immediately or saved for later service, depending on the interrupt's priority. Saving the interrupt for later service is referred to as posting. An interrupt, once posted, becomes a pending interrupt. Hardware and software interrupts are posted differently:

- hardware interrupts are posted by setting the interrupt's assigned bit in the interrupt pending (IPND) special function register
- software interrupts are posted by setting the interrupt's assigned bit in the interrupt table's pending priorities and pending interrupts fields

**Checking Pending Interrupts** – Interrupts posted for later service must be compared to the current process priority. If process priority changes, posted interrupts of higher priority are then serviced. Comparing the process priority to posted interrupt priority is handled differently for hardware and software interrupts. Each hardware interrupt is assigned a specific priority when the processor is configured. The priority of all posted hardware interrupts is continually compared to the current process priority. Software interrupts are posted in the interrupt table in external memory. The highest priority posted in this table is also saved in an on-chip software priority register; this register is continually compared to the current process priority.

**Servicing Interrupts** — If the process priority falls below that of any posted interrupt, the interrupt is serviced. The comparator signals the core to begin a microcode sequence to perform the interrupt context switch and branch to the first instruction of the interrupt routine.

Figure 12-9 illustrates interrupt controller function. For best performance, the interrupt flow for hardware interrupt sources is implemented entirely in hardware.

The comparator only signals the core when a posted interrupt is a higher priority than the process priority. Because the comparator function is implemented in hardware, microcode cycles are never consumed unless an interrupt is serviced.

### 12.3.10 Interrupt Service Latency

12

The time required to perform an interrupt task switch is referred to as *interrupt service latency*. Latency is the time measured between activation of an interrupt source and execution of the first instruction for the accompanying interrupt-handling procedure. In the following discussion, interrupt service latency is derived in number of PCLK2:1 cycles. The established measure of interrupt service latency (in units of seconds) is derived with the following equation:

$$\text{Interrupt Service Latency (in seconds)} = \frac{N_{\text{Lint}}}{f_c} \quad \text{Equation 12-1}$$

where:  $f_c$  = PCLK2:1 frequency (Hz)  
 $N_{\text{Lint}}$  = number of PCLK2:1 cycles

## INTERRUPT CONTROLLER

For real-time applications, worst-case interrupt latency must be considered for critical handling of external events. For example, an interrupt from a FIFO buffer may need service to prevent the FIFO from an overrun condition. For many applications, typical interrupt latency must be considered in determining overall system performance. For example, a timer interrupt may frequently trigger a task switch in a multi-tasking kernel.

The flowchart in Figure 12-9 can be used to determine worst-case interrupt latency. Flowchart values are based on the assumption that the interrupt controller is configured in the following way:

- Hardware interrupt is requested  $\overline{XINT7:0}$  pins or  $\overline{NMI}$
- Fast sample mode - Fast sample mode is selected (ICON.sm=1)
- Cached interrupt vector - Interrupt vector is fetched from internal data RAM. This is automatic for the  $\overline{NMI}$  vector or is selected in the ICON register (ICON.vce=1)
- Cached interrupt handler - Cache hit for interrupt call target
- DMA suspended on interrupt - DMA suspend on interrupt is enabled (ICON.dmas=1)
- Minimum Bus Latency - All memory is configured as zero wait state and burst access mode.

### NOTE:

The worst-case interrupt latency value does not account for interaction of faults and interrupts. It is assumed that faults are not signaled in a stable system.

Because of the processor's instruction mix and the nature of on-chip register cache, typical interrupt latency is derived assuming that the interrupt occurs under the following constraints, in addition to those listed above:

- Interrupts a single cycle RISC instruction
- Frame flush does not occur
- Bus queue is empty

The value for typical interrupt latency ( $N_{L\_int}$ ) is:

$$N_{L\_int} \text{ (typical)} = 30 \text{ PCLK2:1 cycles}$$

**Equation 12-2**

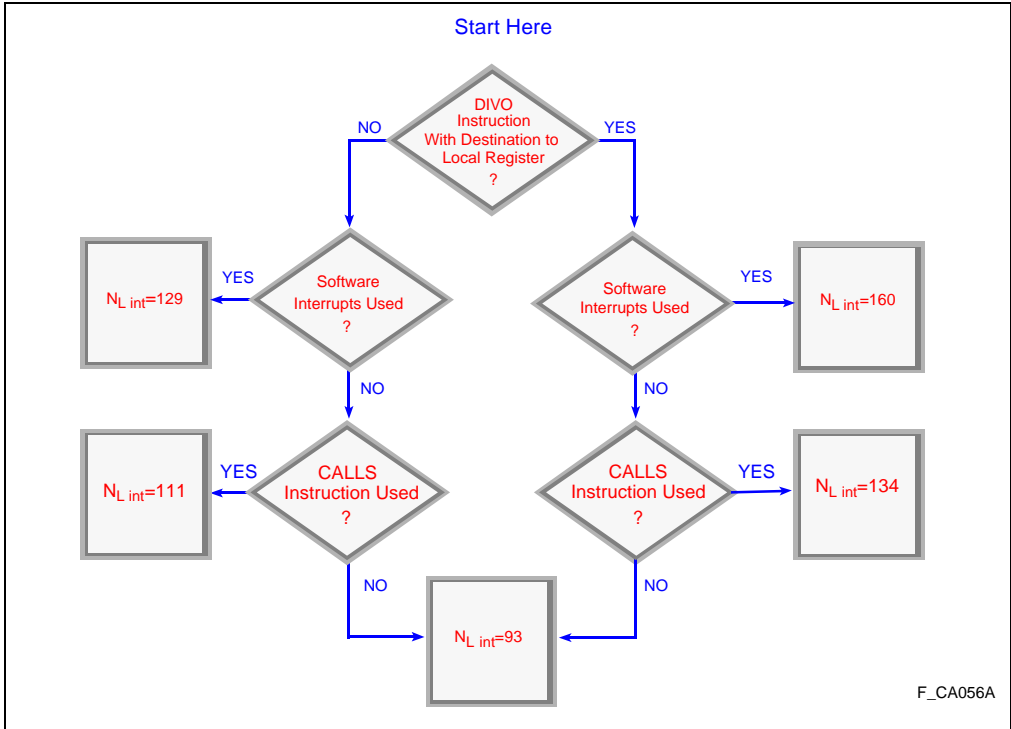


Figure 12-9. Calculation of Worst Case Interrupt Latency -  $N_{L\_int}$

12.3.11 Optimizing Interrupt Performance

The i960 Cx processor has several features aimed at reducing the time required to respond to and service interrupts. The following section describes three methods for reducing interrupt latency:

- caching interrupt vectors on-chip
- DMA suspension while servicing interrupts
- caching of interrupt handling procedure code

Figure 12-9 shows that controlling the use of long instructions may also be used to optimize interrupt performance.



**12.3.12 Vector Caching Option**

To reduce interrupt latency, the i960 Cx processors allow some interrupt table vector entries to be cached in internal data RAM. When the vector cache option is enabled and an interrupt request is serviced which has a cached vector, the controller fetches the associated vector from internal RAM rather than from the interrupt table in memory.

Interrupts with a vector number with four least-significant bits equal to 0010<sub>2</sub> can be cached. The vectors that can be cached coincide with the vector numbers that are selected with the mapping registers and assigned to dedicated-mode inputs. The vector caching option is selected when programming the ICON register; software must explicitly store the vector entries in internal RAM.

Since the internal RAM is mapped directly to the address space, this operation can be performed using the core’s store instructions. Table 12-1 shows the required vector mapping to specific locations in internal RAM. For example, the vector entry for vector number 18 must be stored at RAM location 004H, and so on.

The  $\overline{\text{NMI}}$  vector is also shown in Table 12-1. This vector is always cached in internal data RAM at location 0000H. The processor automatically loads this location at initialization with the value of vector number 248 in the interrupt table.

**Table 12-1. Location of Cached Vectors in Internal RAM**

| Vector Number (Binary) | Vector Number (Decimal) | Internal RAM Address |
|------------------------|-------------------------|----------------------|
| (NMI)                  | 248                     | 0000H                |
| 0001 0010 <sub>2</sub> | 18                      | 0004H                |
| 0010 0010 <sub>2</sub> | 34                      | 0008H                |
| 0011 0010 <sub>2</sub> | 50                      | 000CH                |
| 0100 0010 <sub>2</sub> | 66                      | 0010H                |
| 0101 0010 <sub>2</sub> | 82                      | 0014H                |
| 0110 0010 <sub>2</sub> | 98                      | 0018H                |
| 0111 0010 <sub>2</sub> | 114                     | 001CH                |
| 1000 0010 <sub>2</sub> | 130                     | 0020H                |
| 1001 0010 <sub>2</sub> | 146                     | 0024H                |
| 1010 0010 <sub>2</sub> | 162                     | 0028H                |
| 1011 0010 <sub>2</sub> | 178                     | 002CH                |
| 1100 0010 <sub>2</sub> | 194                     | 0030H                |
| 1101 0010 <sub>2</sub> | 210                     | 0034H                |
| 1110 0010 <sub>2</sub> | 226                     | 0038H                |
| 1111 0010 <sub>2</sub> | 242                     | 003CH                |



### 12.3.13 DMA Suspension on Interrupts

Core resources required to execute a DMA operation may impact interrupt latency. A DMA operation may be temporarily suspended to reduce the effects of the DMA when interrupt-response time is critical. The DMA suspension option is programmed in the ICON register. When the option is selected, the core suspends DMA processing while executing a call to an interrupt-handling procedure for a hardware-requested interrupt. Once the core begins executing the interrupt procedure, it restores DMA processing.

To improve interrupt throughput, DMA processing can be suspended until the execution of an interrupt-handling procedure is complete. To accomplish this, the interrupt procedure must explicitly suspend DMA operation by clearing the DMA command register's channel enable field. See section 13.10.1, "DMA Command Register (DMAC)" (pg. 13-21) for more information.

### 12.3.14 Caching Interrupt-Handling Procedures

Fetching the first instructions of an interrupt-handling procedure from external memory impacts interrupt latency and throughput. The controller eliminates the fetch time by providing a mechanism to lock procedures — or portions of procedures — in the processor's instruction cache. Using this cache locking feature, particular interrupt handlers can always be fetched from on-chip instruction cache, eliminating the latency incurred from fetching the handlers from external memory. Paragraphs that follow describe cache locking of interrupt procedures.

All, half, or none of the instruction cache can be pre-loaded and locked. Typically, one half is used as normal instruction cache and the other half for locking instructions. The i960 CA processor allows only interrupt procedures to be locked in the cache. An improved mechanism on the i960 CF processor has fewer restrictions: any section of code can be locked into the cache — not just interrupt procedures.

**sysctl** provides the mechanism for locking sections of procedures into the cache. Instructions to be locked must first be linked to a contiguous block in external memory. The block must be aligned to a quad-word address. Next, **sysctl** is issued with the configure instruction cache message type. The starting address of the block in memory is specified as an operand of the instruction.

The i960 CA processor supports 512 bytes or 1 Kbytes of locked cache. The i960 CF processor, with larger instruction cache, supports 2 Kbytes or 4 Kbytes of locked cache. As indicated in Table 12-2, the mode field of the **sysctl** instruction specifies the size of locked cache.

**Table 12-2. Cache Configuration Modes**

| Mode Field       | Mode Description  | 80960CA              | 80960CF               |
|------------------|---|----------------------|-----------------------|
| 000 <sub>2</sub> | normal cache enabled  | 1 Kbyte              | 4 Kbytes              |
| XX1 <sub>2</sub> | full cache disabled   | 1 Kbyte              | 4 Kbytes              |
| 100 <sub>2</sub> | Load and lock half cache (execute off-chip)                     | 1 Kbyte <sup>1</sup> | 2 Kbytes <sup>2</sup> |
| 110 <sub>2</sub> | Load and lock half the cache; remainder is normal cache enabled | 512 bytes            | 2 Kbytes              |
| 010 <sub>2</sub> | Reserved  | 1 Kbyte              | 4 Kbytes              |

**NOTES:**

1. On the CA, only interrupt procedures can execute in the locked portion of the cache.
2. On the CF, interrupt procedures and other code can operate in the locked portion of the cache.

When **sysctl** executes (mode 110<sub>2</sub>) with a command to lock half of the instruction cache, one way of the i960 CF processor’s two-way set associative cache is preloaded and locked from the specified address. The other half of the instruction cache functions as a 2 Kbyte direct-mapped instruction cache. On the i960 CA processor, the instruction cache’s unlocked portion functions as a 512 byte two-way set associative cache.

The i960 CF processor’s instruction scheduler checks both ways of the cache for every instruction fetched. If an instruction is not found in either way, it is fetched from external memory and cached in the unlocked way.

The i960 CA processor only allows interrupt handlers to be locked in the cache. The interrupt vector’s two least-significant bits must be set to 010<sub>2</sub> to cause the processor to fetch the interrupt procedure from locked cache rather than the normal memory/cache hierarchy. The interrupt procedure executes from the locked cache until a miss occurs in the locked section.

The cache remains locked until the cache mode is changed by the next **sysctl** instruction. The invalidate instruction cache **sysctl** message invalidates both the locked and unlocked halves of the cache. Refer to section 4.3, “SYSTEM CONTROL FUNCTIONS” (pg. 4-19) for details on using the **sysctl** instruction to configure the instruction cache.

**ERRATA:**  
 06/14/94:  
 Page 12-22, Table 12-2  
 For the CF, Mode 100<sub>2</sub>  
 was incorrectly shown as  
 locking 4 Kbytes; it now  
 correctly shows 2 Kbytes.  
 This errata also occurs  
 on page 4-22.



# DMA CONTROLLER







## CHAPTER 13

# DMA CONTROLLER

This chapter describes the i960® Cx processor's integrated Direct Memory Access (DMA) Controller: its operation modes, setup, external interface and DMA controller implementation.

### 13.1 OVERVIEW

The DMA controller concurrently manages up to four independent DMA channels. Each channel supports memory-to-memory transfers where the source and destination can be any combination of internal data RAM or external memory. The DMA mechanism provides two unique methods for performing DMA transfers:

- Demand-mode transfers (synchronized to external hardware). Typically used for transfers between an external device and memory. In demand mode, external hardware signals for each channel are provided to synchronize DMA transfers with external requesting devices.
- Block-mode transfers (non-synchronized). Typically used to move blocks of data within memory.

To perform a DMA operation, the DMA controller uses microcode, the core's multi-process resources, the bus controller and internal hardware dedicated to the DMA controller. Loads and stores execute in DMA microcode to perform each transfer. The bus controller, directed by DMA microcode, handles data transactions in external memory. DMA controller hardware synchronizes transfers with external devices or memory, provides the programmer's interface to the DMA controller and manages the priority for servicing the four DMA channels.

The DMA controller uses multi-process resources, designed into the core, to enable DMA operations to execute in microcode concurrently with the user's program. This sharing of core resources is accomplished with hardware-implemented processes for each of the four DMA channels (the *DMA processes*) and a separate process for the user's program (the *user process*). Alternating between DMA processes and the user process enables a user's program and up to four DMAs (one per channel) to run at the same time.

To execute a DMA operation, a DMA process issues memory load or store requests. The bus controller executes these memory processes as it would a load, store or prefetch request from the user process. External bus access is shared equally between the user and DMA process. The bus controller executes bus requests by each process in alternating fashion.

The DMA controller is configurable to best exploit the core's processing capabilities and external bus performance. Source and destination request lengths are programmed for each DMA channel. Based on request length, the DMA controller optimizes transfer performance between source and destination with different external data bus widths. A DMA can be programmed for quad-word transfers, taking best advantage of external bus burst capabilities. The DMA controller can also efficiently execute transfers of unaligned data.

A single cycle “fly-by” transfer mode gives the highest performance transfers for a DMA. In this mode, a single bus request executes a transfer of data from source to destination.

A data-chaining mode simplifies several commonly-performed DMA operations such as scatter or gather. Data-chained DMAs are configured with a series of descriptors in memory. Each descriptor describes the transfer of a single buffer or portion of the entire DMA. These descriptors can be dynamically changed as the chained DMA progresses.

DMA setup and control is simple and efficient. The setup DMA (**sdma**) instruction sets up a DMA operation. **sdma** specifies addressing, transfer type and DMA modes. A special-function register — the DMA command register (DMAC) — is an interface for commonly-used command and status functions for each channel.

Flexibility and a high degree of programmability for a DMA operation create a number of options for balancing DMA and processor performance and DMA latency. This flexibility enables the programmer to select the best DMA configuration for a particular application.

## 13.2 DEMAND AND BLOCK MODE DMA

A channel can be configured as a demand mode or block mode DMA channel. Demand mode DMAs move data between memory and an external I/O device; block mode DMAs typically move blocks of data from memory to memory.

When a channel is configured for demand mode, an external device requests a DMA transfer with a DMA request input  $\overline{\text{DREQ3:0}}$ . The DMA controller acknowledges the requesting device with a DMA acknowledge signal  $\overline{\text{DACK3:0}}$ . The  $\overline{\text{DACK3:0}}$  signal is asserted during the bus request which the DMA controller makes to the requesting device. Specific  $\overline{\text{DREQ3:0}}$  and  $\overline{\text{DACK3:0}}$  signal relationships are described in section 13.11, “DMA EXTERNAL INTERFACE” (pg. 13-30). After a DMA channel is configured, the channel must be enabled by software through the DMA command register (DMAC). The DMA operation continues until it:

- is terminated (by an external source with  $\overline{\text{EOP}}$ )
- is suspended (by software)
- ends because of a zero byte count

An interrupt may be generated to detect any of these three cases.



### 13.3 SOURCE AND DESTINATION ADDRESSING

When a DMA operation is set up, it is described with a source address, destination address and byte count. For each channel, an address is either held fixed or incremented after each transfer. A fixed address is used for addressing external I/O devices; an address which increments is used for the memory side of a DMA transfer. When a channel is set up, address increment or hold is selected separately for the source and destination address.

Source and destination address and byte count are 32-bit values. Source and destination are byte addressable over the entire address space. DMA operation length can be up to 4 Gbytes ( $2^{32}$  Bytes). Source and destination address and byte count are specified when **sdma** executes.

### 13.4 DMA TRANSFERS

The following sections explain DMA transfer characteristics, especially those transfer characteristics affected by channel setup. Intelligent selection of transfer characteristics works to balance DMA performance and functionality with the performance of the user's program.

Source/destination request length selects the bus request types which the DMA microcode issues when executing a DMA transfer. To perform a transfer, combinations of byte, short-word, word and quad-word load and store requests are issued. Refer to section 11.2, "BUS OPERATION" (pg. 11-2) for a detailed description of bus request.

As indicated in Table 13-1, transfer type is specified when a channel is set up using **sdma**. Transfer type specifies source/ destination request length for a DMA operation and whether DMA transfer is performed as a multiple-cycle transfer or as a fly-by (1 bus cycle) transfer. Multi-cycle transfer is performed with two or more bus requests; fly-by transfer with a single bus request. Fly-by and multi-cycle transfers are described in the following sections.

#### 13.4.1 Multi-Cycle Transfers

Multi-cycle DMA transfer comprises two or more bus requests. For these multi-cycle transfers, loads from a source address are followed by stores to a destination address. To execute the transfer, DMA microcode issues the proper combination of bus requests. For example, a typical multi-cycle DMA transfer could appear as a single byte load request followed by a single byte store request.

**Table 13-1. Transfer Type Options**

| Source Request Length | Destination Request Length | Transfer Type |
|-----------------------|----------------------------|---------------|
| Byte (8 bits)         | Byte (8 bits)              | Multi-Cycle   |
| Byte (8 bits)         | Byte (8 bits)              | Fly-by        |
| Byte (8 bits)         | Short (16 bits)            | Multi-Cycle   |
| Byte (8 bits)         | Word (32 bits)             | Multi-Cycle   |
| Short (16 bits)       | Byte (8 bits)              | Multi-Cycle   |
| Short (16 bits)       | Short (16 bits)            | Multi-Cycle   |
| Short (16 bits)       | Short (16 bits)            | Fly-by        |
| Short (16 bits)       | Word (32 bits)             | Multi-Cycle   |
| Word (32 bits)        | Byte (8 bits)              | Multi-Cycle   |
| Word (32 bits)        | Short (16 bits)            | Multi-Cycle   |
| Word (32 bits)        | Word (32 bits)             | Multi-Cycle   |
| Word (32 bits)        | Word (32 bits)             | Fly-by        |
| Quad-Word (128 bits)  | Quad-Word (128 bits)       | Multi-Cycle   |
| Quad-Word (128 bits)  | Quad-Word (128 bits)       | Fly-by        |

For a multi-cycle transfer, source data is first loaded into on-chip DMA registers before it is stored to the destination. The processor effectively buffers the data for each transfer. When a DMA transfer is configured for destination synchronization, the DMA controller buffers source data, waiting for the request (active  $\overline{\text{DREQ3:0}}$  signal) from the destination requestor. This operation reduces latency. The initial DMA request, however, still requires the source data to be loaded before the request is acknowledged. Source data buffering is shown in Figure 13-1. The DMA controller does not perform multi-cycle transfers atomically. A DMA transfer does not cause the processor's  $\overline{\text{LOCK}}$  output to be asserted. A bus hold request may also be acknowledged between the bus requests which make up a multi-cycle transfer.



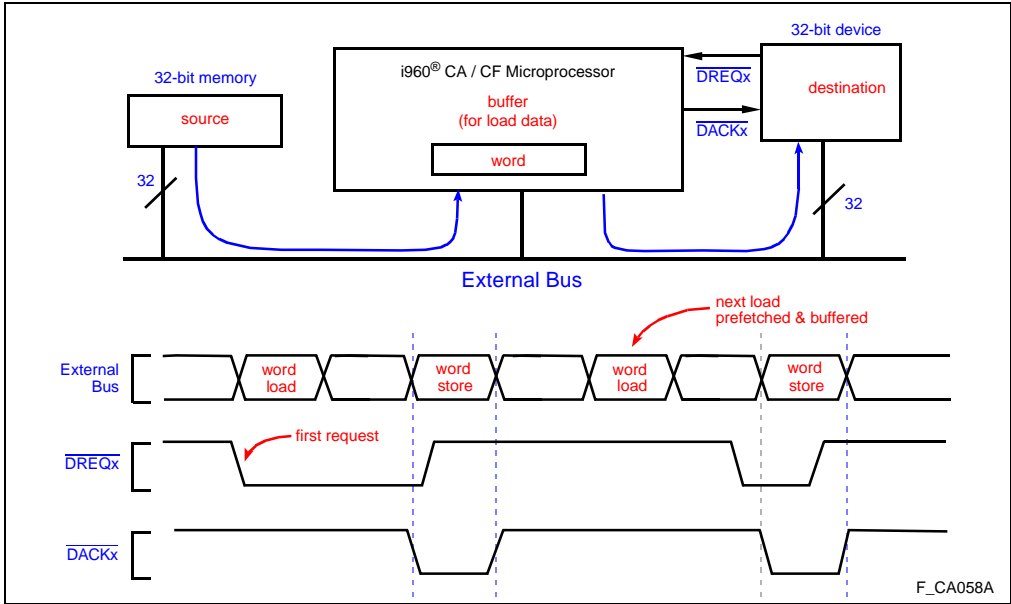


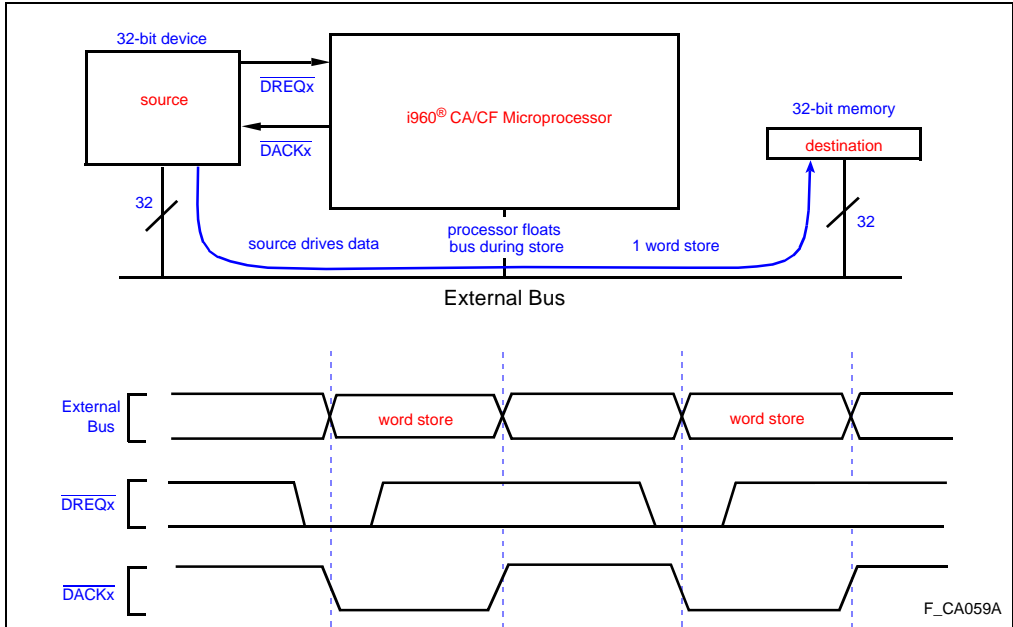
Figure 13-1. Source Data Buffering for Destination Synchronized DMAs

13.4.2 Fly-By Single-Cycle Transfers

Fly-by transfers are executed with only a single load or store request. Source data is not buffered internally; instead, the data passes directly between source and destination via the external data bus. This makes fly-by the fastest DMA transfer type.

Fly-by transfers are commonly used for high-performance peripheral to memory transfers. The fly-by mechanism is best described by giving an example of a source-synchronized demand mode DMA (Figure 13-2). In the example, a peripheral at a fixed address is the source of a DMA and memory is the destination. Each transfer is synchronized with the source.

The source requests a transfer by asserting the request pin  $\overline{DREQ3:0}$ . When the request is serviced, a store is issued to the destination memory while the requesting device is selected by the DMA acknowledge pin  $\overline{DACK3:0}$ . The source device, when selected, must drive the data bus for the store instead of the processor. (The processor floats the data bus for a fly-by transfer.)



**Figure 13-2. Example of Source Synchronized Fly-by DMA**

If the destination of a fly-by is the requestor (destination synchronization), a load is issued to the source while the destination is selected with the acknowledge pin. The destination, when selected, reads the load data; the processor ignores the data from the load.

**NOTE:**

Fly-by mode may not access internal data RAM.

A fly-by DMA in block mode is started by software, as is any block-mode operation. Request pins DREQ3:0 are ignored in block mode. Fly-by block-mode DMAs can be used to implement high-performance memory-to-memory transfers where source and destination addresses are fixed at block boundaries. In this case, the acknowledge pin must be used in conjunction with external hardware to uniquely address the source and destination for the transfer.

**13.4.3 Source/Destination Request Length**

Source and destination request length is selected when a DMA channel is configured. Request length determines bus request types that the DMA microcode issues. Byte, short-word or quad-word bus requests are issued by the DMA controller microcode. Figure 13-3 illustrates source-synchronized DMA loads.



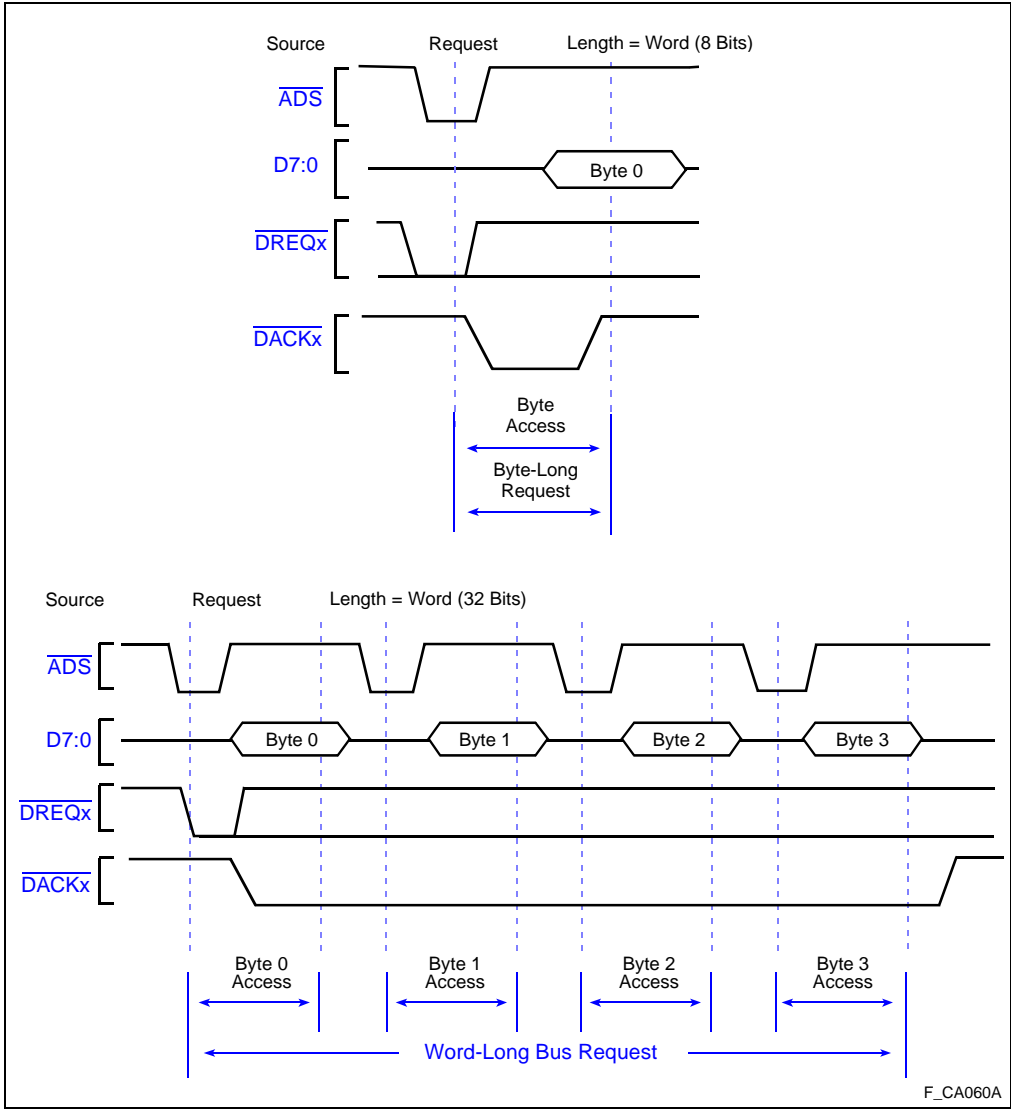


Figure 13-3. Source Synchronized DMA Loads from an 8-bit, Non-burst, Non-pipelined Memory Region

The request length selected for a DMA operation — byte, short-word, word or quad-word — should not be confused with external data bus width or other characteristics programmed in the memory region configuration table. Request length dictates the type of bus request issued by DMA controller microcode, while the region configuration of a DMA's source and destination memory control how that bus request is executed on the external bus.

As an example, consider a system in which a DMA source memory region is configured for 8-bit, non-burst accesses and a word source request length is selected. DMA microcode issues word loads (identical to the **ld** instruction) to DMA addresses in the source region. Since the source memory region is configured as 8 bits, the bus controller handles the word loads as four 8-bit accesses in that region. To contrast this example, if the DMA is configured for a byte source request length, DMA microcode issues byte loads (identical to the **ldob** instruction) to DMA addresses in the source region. The byte load to this region is executed as a single 8-bit access. CHAPTER 11, EXTERNAL BUS DESCRIPTION fully describes bus configuration and how the bus controller executes bus requests.

In demand mode transfers,  $\overline{\text{DREQ3:0}}$  is asserted to request a DMA transfer.  $\overline{\text{DACK3:0}}$  is asserted during the bus request issued in response to the DMA request. Continuing the example started above: if the DMA controller is set up for source synchronized demand mode,  $\overline{\text{DREQ3:0}}$  causes a word (**ld**) request to be issued when source request length equals word and causes a byte (**ldob**) request to be issued when the source request length equals byte.  $\overline{\text{DACK3:0}}$  is asserted for the duration of the bus request for each case.

For demand mode transfers, the request length is typically selected to match the external bus width of the external DMA device. If request length is greater than bus width, the DMA device must be designed to support multiple data cycles for each DMA transfer requested. This may be accomplished by using a small FIFO and an external circuit to load and unload the FIFO. This method reduces bus loading by the DMA process.

For block mode transfers, source and destination request lengths are typically selected to match external data bus width. This configuration uses the external bus most efficiently and also reduces latency for bus requests issued by the user process.

In instances where source and destination bus widths are different, DMA performance may be increased by setting up the DMA with matching source and destination request lengths. This configuration reduces DMA microcode overhead required to pack or unpack data between unequal request lengths. Packing/unpacking is handled more efficiently by the bus controller unit. Matching the request lengths may increase latency for bus requests issued by the user process.

Quad-word source and destination request lengths are used for highest DMA performance. Quad transfers use the external bus most efficiently when the source or destination memory regions support burst accesses. Since the request length for quad word transfers is always greater than the bus width, DMA devices must support multiple data cycles for each requested DMA transfer. Using quad-word request lengths may increase bus latency for loads, stores and instruction fetches that the user's program generates.



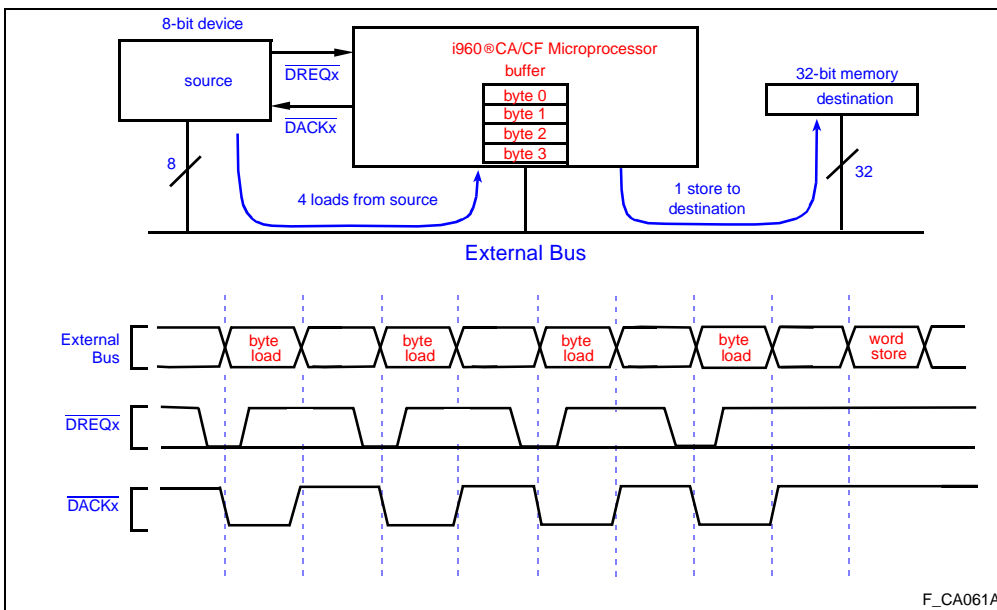


In cases where source address, destination address or byte count are unaligned, requests shorter than the selected request length are issued to align the transfers. Refer to section 13.4.5, “Data Alignment” (pg. 13-10).

**13.4.4 Assembly and Disassembly**

The DMA controller internally assembles or disassembles data between different source and destination request lengths. Assembly refers to the packing of narrow data into wider data. Disassembly refers to the unpacking of wide data into narrow data. Assembly and disassembly is performed automatically when a channel is set up with different source and destination request lengths. Assembly and disassembly are performed for all aligned transfers configured with combinations of byte, short-word and word request lengths. Quad-word DMA transfers require that source and destination request lengths equal quad word; therefore, data assembly and disassembly are not applicable to this DMA mode.

Figure 13-4 shows a typical demand mode configuration in which an 8-bit device is the source requestor for a DMA and 32-bit memory is the destination. If byte source and word destination request length is selected for this DMA, data from four source requests is buffered before a load to the 32-bit memory is executed. This configuration represents an optimal use of bus resources for a DMA between an 8-bit device and 32-bit memory.



**Figure 13-4. Byte to Word Assembly**

Microcode algorithms which perform assembly and disassembly are less efficient than algorithms which perform transfers between source and destination with equal request lengths. DMA controller assembly and disassembly is provided for convenience and for most efficient external bus usage. For example, the system shown in Figure 13-4 functions the same when source and destination request lengths are both byte-long. In this case, each transfer is performed with a byte load followed by a byte store. DMA throughput is increased; however, the DMA makes more bus requests to transfer the same amount of data.

**13.4.5 Data Alignment**

The DMA controller can handle fully unaligned DMA transfers under most circumstances. When both the source and destination address increment, there are no alignment requirements for byte, short or word transfers. The byte count may also be unaligned, or any value. Addresses for all quad-word request transfer modes must always be quad-word aligned and the byte count must always be evenly divisible by 16.

To interface to external DMA devices, the source or destination address may be set up as fixed. Fixed addresses must always be aligned to the request-length boundary. The byte count for the fixed addressing mode must be evenly divisible by the width of the fixed transfer. For example, a 32-16 transfer with a fixed destination address must have the byte count evenly divisible by two. Table 13-3 summarizes the alignment requirements for all DMA transfers.

The byte count alignment depends on DMA controller configuration (see Table 13-2). For proper operation, the byte count must be evenly divisible by the byte count alignment value. For example, the byte count for a 32-bit fly-by transfer must be evenly divisible by four.

**Table 13-2. DMA Configuration and Byte Count Alignment**

| Configuration  | Byte Count Alignment                   |
|--|--|
| Multi-cycle block mode with byte, short-word or word long source or destination request length | 1                                      |
| All quad word transfers  | 16                                     |
| Multi-cycle mode at least one address fixed  | smallest fixed transfer length (bytes) |
| Multi-cycle mode both addresses incrementing   | 1                                      |
| All fly-by mode transfers  | transfer length (bytes)                |

Multi-cycle DMAs to aligned memory blocks perform better than DMAs to unaligned memory blocks. Additional microcode cycles are required to access the unaligned memory.



Most unaligned DMA transfers, however, use the external bus almost as efficiently as aligned DMAs. Multi-cycle DMA configurations which use the bus efficiently when memory blocks are unaligned are:

- Word-to-Word
- Byte-to-Short
- Byte-to-Word
- Short-to-Byte
- Word-to-Byte

**Table 13-3. DMA Transfer Alignment Requirements**

| Transfer Types<br>(Source-to-Destination) | Boundary Alignment Requirements     |       |                        |       |      |
|---|-------------------------------------|-------|------------------------|-------|------|
|   | Source Address<br>or Fly-by Address |       | Destination<br>Address |       |      |
|   | Fixed                               | Incr. | Fixed                  | Incr. |      |
| Byte-to-Byte (8/8 bit)                    | Multi-cycle                         | Byte  | Byte                   | Byte  | Byte |
|   | Fly-by                              | Byte  | Byte                   | N/A   | N/A  |
| Byte-to-Short (8/16 bit)                  | Multi-cycle                         | Byte  | Byte                   | Short | Byte |
| Byte-to-Word (8/32 bit)                   | Multi-cycle                         | Byte  | Byte                   | Word  | Byte |
| Short-to-Byte (16/8 bit)                  | Multi-cycle                         | Short | Byte                   | Byte  | Byte |
| Short-to-Short (16/16 bit)                | Multi-cycle                         | Short | Byte                   | Short | Byte |
|   | Fly-by                              | Short | Short                  | N/A   | N/A  |
| Short-to-Word (16/32 bit)                 | Multi-cycle                         | Short | Byte                   | Word  | Byte |
| Word-to-Byte (32/8 bit)                   | Multi-cycle                         | Word  | Byte                   | Byte  | Byte |
| Word-to-Short (32/16 bit)                 | Multi-cycle                         | Word  | Byte                   | Short | Byte |
| Word-to-Word (32/32 bit)                  | Multi-cycle                         | Word  | Byte                   | Word  | Byte |
|   | Fly-by                              | Word  | Word                   | N/A   | N/A  |
| Quad-to-Quad (128/128 bit)                | Multi-cycle                         | Quad  | Quad                   | Quad  | Quad |
|   | Fly-by                              | Quad  | Quad                   | N/A   | N/A  |

## DMA CONTROLLER

Unaligned transfers are best utilized for block mode memory-to-memory transfers. However, the synchronizing modes can also be fully unaligned given the restrictions in Table 13-3. These optimized unaligned transfers are executed by performing byte requests until alignment is enforced. At this time, aligned source and destination requests are executed. At end of transfer, the DMA may revert to byte transfers to complete the DMA. While aligning the addresses, the same location may be read more than once. Also, the synchronizing device may be required to supply fewer or more bytes per transfer. For example, in 32-32 destination synchronized demand mode the destination could be written with 1 to 7 bytes per  $\overline{\text{DREQ}}$ .

When unaligned, the number of  $\overline{\text{DREQ}}$ s required to complete a transfer is very difficult to calculate, given the large number of permutations. It may be greater than the byte count divided by the transfer width. Each  $\overline{\text{DREQ}}$  will generate a single  $\overline{\text{DACK}}$ . This makes it much easier for external hardware to assert  $\overline{\text{DREQ}}$ , based on the  $\overline{\text{DACK}}$  output.

This alignment mechanism is shown in Figure 13-5. This is an example of a 32-32 source synchronized transfer with source at 0x201, destination at 0x303 and a byte count of 12. It takes five  $\overline{\text{DREQ}}$ s to complete this transfer, with  $\overline{\text{DACK}}$  asserted for every access to the source.

Alignment overhead occurs at the beginning and end of the DMA operation and, depending on DMA byte count, may be negligible. For short-short, short-to-word and word-to-short multi-cycle transfers, the DMA performs byte requests when a memory block is unaligned.



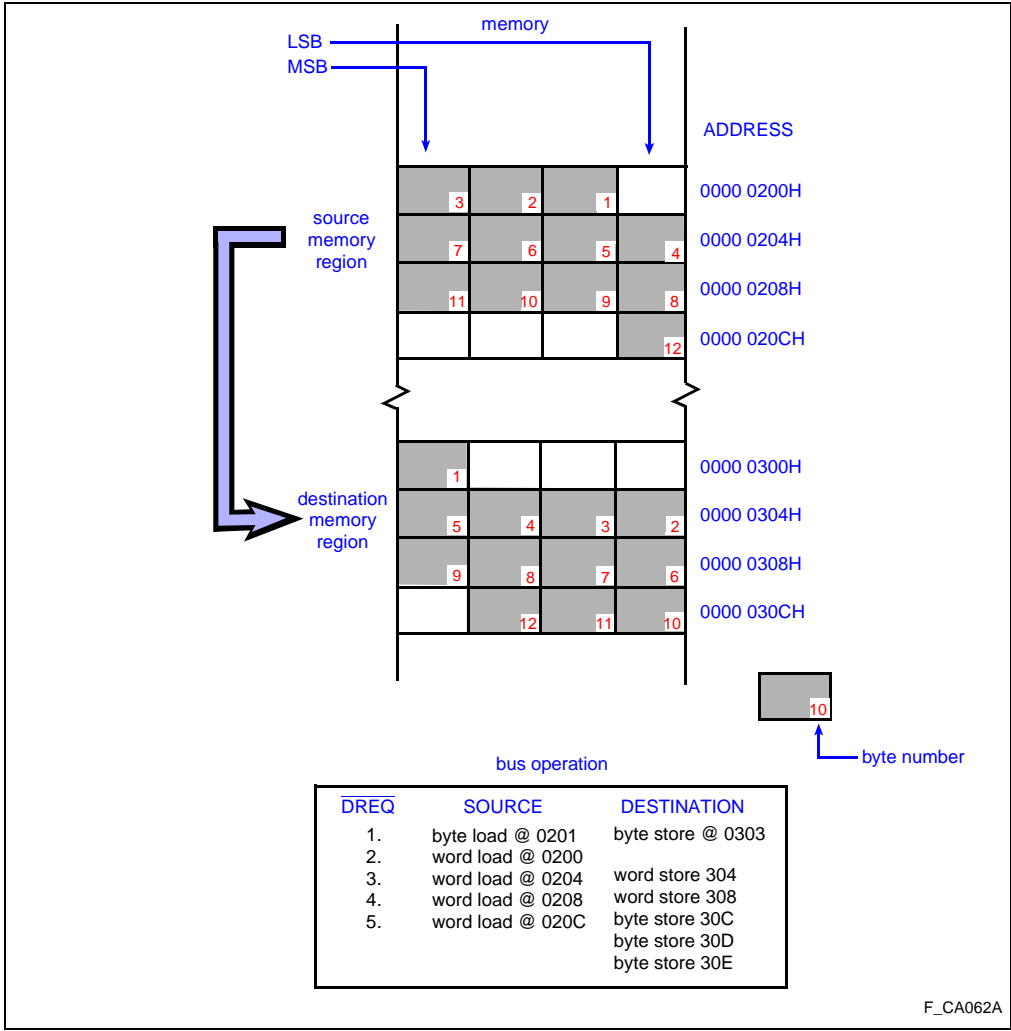


Figure 13-5. Optimization of an Unaligned DMA

### 13.5 DATA CHAINING

Data chaining can generate complex DMAs by linking together multiple transfer operations and is accomplished by using memory-based chaining descriptors to describe component parts of a more complex DMA operation.

The component parts of the chained DMA are referred to as chaining buffers. To describe a single DMA chaining buffer, a chaining descriptor (Figure 13-6) supplies source address (SA), destination address (DA) and byte count (BC). Chaining buffers are linked together with the value of the next pointer (NPTR) field in the chaining descriptor. NPTR contains the chaining descriptor address which describes the next part of the chained DMA operation. DMA operation ends when a NPTR of 0 (null pointer) is encountered.

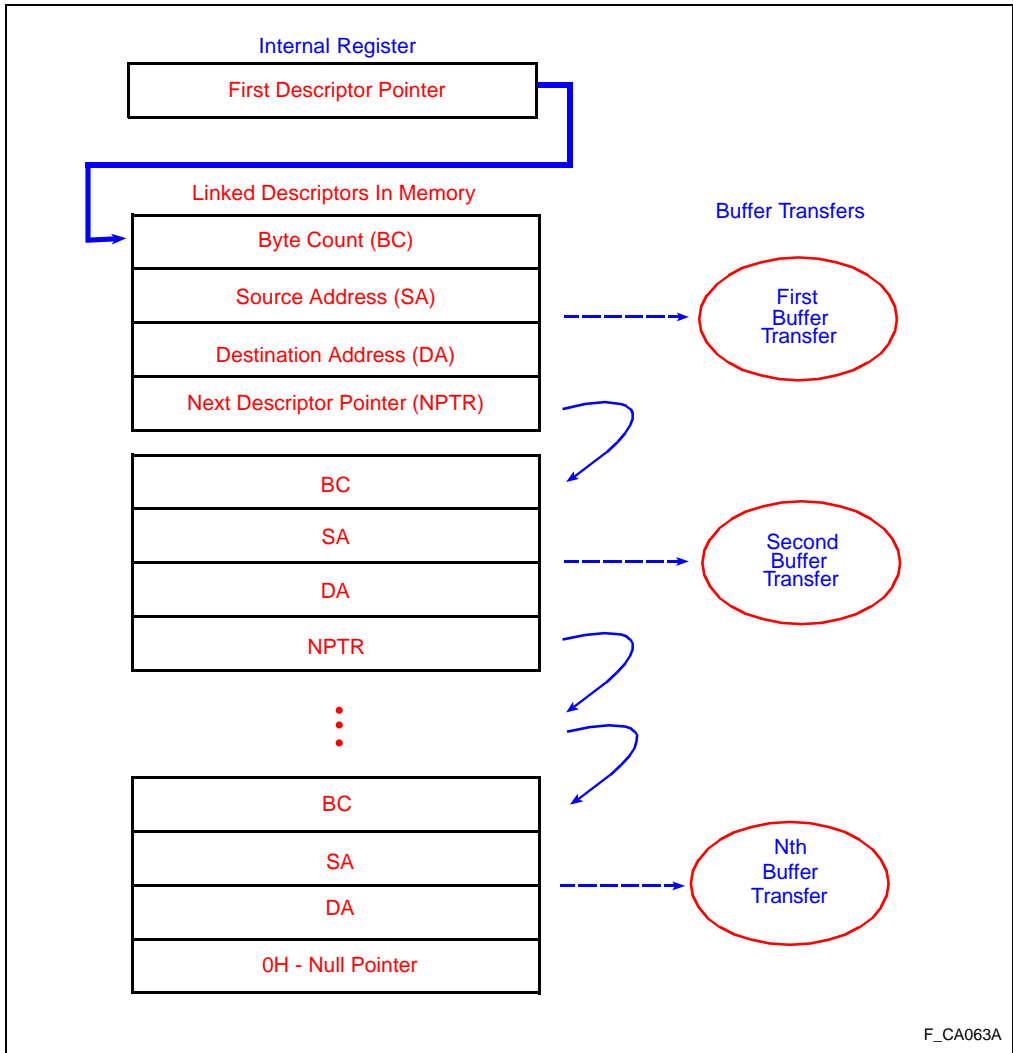


Figure 13-6. DMA Chaining Operation



A chained DMA operation is started by specifying a pointer to the first chaining descriptor when **sdma** is used to configure the DMA channel. Initial source address, destination address and byte count are taken from the first chaining descriptor. Chained DMAs are configured such that subsequent buffer transfers use either source, destination or both of these addresses to continue the chained DMA. These modes are referred to as source chaining, destination chaining or source/destination chaining. For example, if a channel is configured for source chaining (Figure 13-7), the source address for the DMA operation is updated to the value specified in each new descriptor. The destination address is continually incremented from the address specified in the DA field of the first descriptor or is held fixed at that address. (Addresses may be incremented or held fixed for any DMA operation.)

Each buffer transfer is handled as if it were a single non-chained DMA. Data alignment requirements for each buffer are identical to the requirements for any other DMA. See section 13.4.5, “Data Alignment” (pg. 13-10). Since each buffer is considered a single DMA, data is never internally buffered when moving from one buffer to another for unaligned DMAs.

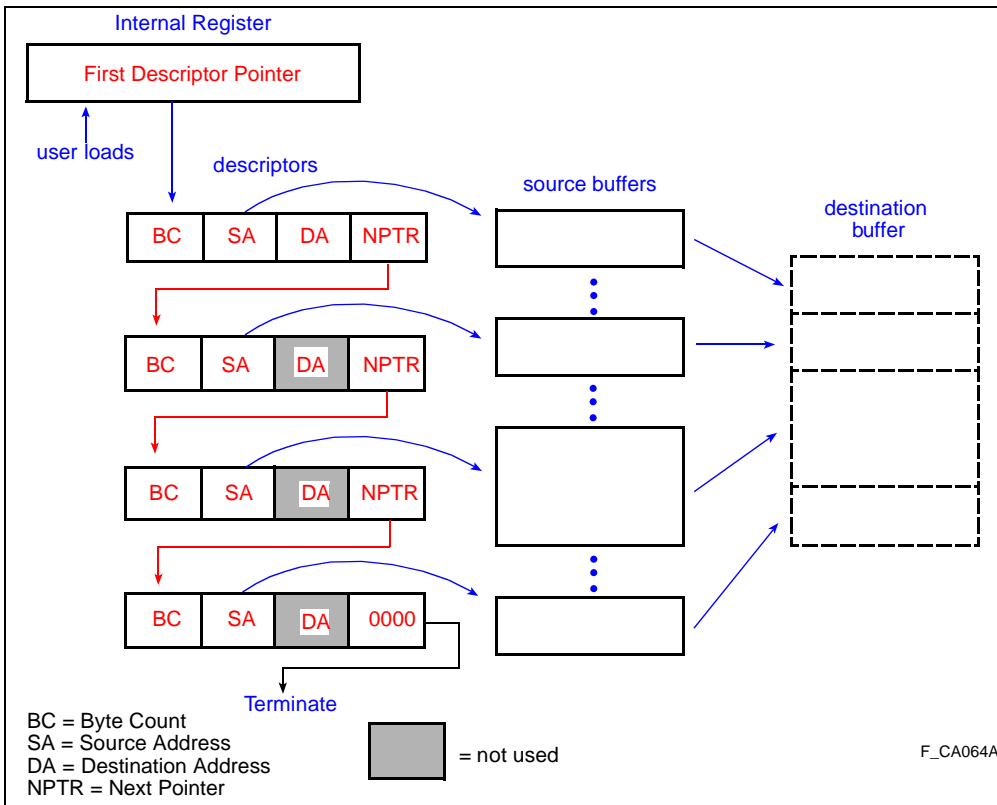


Figure 13-7. Source Chaining

Depending on DMA channel configuration and the chaining mode selected, certain fields in the chaining descriptor are ignored, but must be set to zero for future compatibility:

1. When a channel is source chained, the DA field of the first descriptor specifies the destination address; the DA field in subsequent descriptors is ignored.
2. When a channel is destination chained, the SA field of the first descriptor specifies the source address; the SA field in subsequent descriptors is ignored.
3. When a channel is configured for chained fly-by mode, the SA field always contains the fly-by address; the DA field is ignored.

When descriptors are read from external memory, bus latency and memory speed affect chaining latency. Chaining latency is defined as the time required for the DMA controller to access the next descriptor plus the time required to set up for the next buffer transfer. Chaining latency is reduced by placing descriptors in internal data RAM or fast memory.

### 13.6 DMA-SOURCED INTERRUPTS

Each DMA channel is the source for one interrupt. When a DMA channel signals an interrupt, the DMA interrupt-pending bit corresponding to that channel is set in the interrupt-pending (IPND) register. Each channel's interrupt can be selectively masked in the interrupt mask (IMSK) register or handled as a dedicated hardware-requested interrupt. Refer to CHAPTER 6, INTERRUPTS for a complete description of hardware-requested interrupts.

The interrupt-pending bit for a DMA channel is set for the following conditions:

1. A non-chained DMA terminates because byte count reaches zero (0) or a chained DMA terminates because the null chaining pointer is reached.
2.  $\overline{\text{EOP3:0}}$  pin is programmed as an input and asserted after a **sdma** is performed.
3. For a chained DMA, the interrupt-on-buffer-complete function is enabled and the end of a chaining buffer is reached.





13.7 SYNCHRONIZING A PROGRAM TO CHAINED BUFFER TRANSFERS

When any of the conditions listed above occur, the current DMA request is completed before the pending bit in the IPND register is set. Two mechanisms, illustrated in Figure 13-8, enable a program to synchronize with a completed chained buffer transfer. With either mechanism, an interrupt is generated when the chained buffer is complete. The distinction between the mechanisms are:

1. DMA operation continues with no delay on the next chaining buffer. The interrupt service routine may process the data transferred for the completed buffer.
2. DMA waits until the user program processes the first chaining buffer and sets up the next buffer transfer by modifying the chaining descriptors. DMA continues with the next buffer transfer when a bit in the DMA control register (DMAC) is cleared.

These options are selected when the DMA channel is set up with the **sdma** instruction.

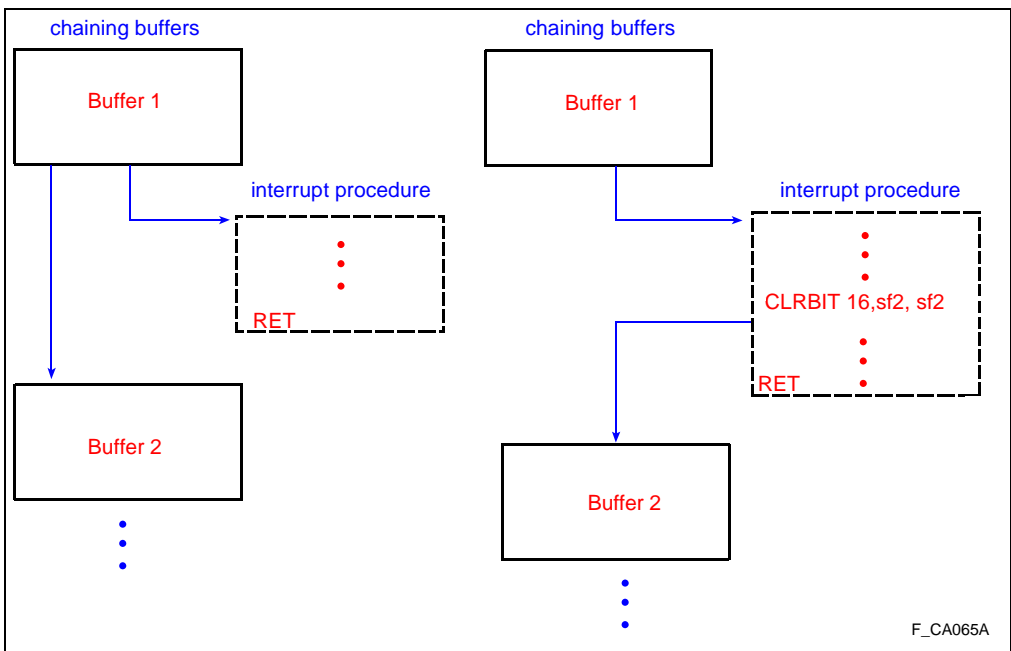


Figure 13-8. Synchronizing to Chained Buffer Transfers

### 13.8 TERMINATING A DMA

A DMA operation normally ends when one of the following events is encountered:

- DMA byte count reaches zero (0) for a non-chained DMA mode.
- $\overline{EOP3:0}$  pin programmed as an input becomes active for a channel that is non-chained, source-only chained or destination-only chained.
- $\overline{EOP3:0}$  pin programmed as an input becomes active during the last buffer transfer for a channel which is source/destination chained.
- The null chaining pointer is encountered in any chaining mode.

The DMA takes the following actions when any one of these events occur:

- DMAC register channel done flag is set.
- DMAC register channel terminal count flag is set, only if the byte count has reached zero (0) (non-chained) or the null chaining pointer is reached (chaining).
- DMAC register channel active bit is reset after all channel activity has completed.
- IPND register channel interrupt pending bit is set. If the corresponding bit in the IMSK is cleared, an interrupt is signaled.

When a chained DMA channel is set up for source/destination chaining, the  $\overline{EOP3:0}$  inputs are designed to terminate only the current chaining buffer. The DMA controller continues normally with the next buffer transfer. The DMA ends as described above if the  $\overline{EOP3:0}$  pin is asserted during the last buffer transfer.

When  $\overline{EOP3:0}$  is asserted, the entire DMA bus request completes before the DMA terminates. For example, assume the DMA is programmed for quad-word transfers. If  $\overline{EOP3:0}$  is asserted, the entire quad-word is transferred before the DMA terminates.

The DMA controller may be configured to generate an interrupt when a DMA terminates. A program may determine how a DMA has ended by reading the DMAC register channel terminal count and channel done flag values:

- If a channel's terminal count flag and done flag are set, the DMA has ended due to a byte count of 0 (non-chaining) or a null chaining pointer reaching 0 (chaining).
- If only the done flag is set for the channel, the DMA has ended because of an active  $\overline{EOP3:0}$  input.

For source/destination chained DMAs, an interrupt is generated by asserting  $\overline{EOP3:0}$  to terminate the current chaining buffer.



**NOTE:**

An interrupt is generated when:

- $\overline{\text{EOP3:0}}$  is asserted; or
- when a buffer transfer is complete and the interrupt-on-buffer complete mode is enabled.

There is no way in software to distinguish between these two interrupt sources. If this distinction is necessary, the  $\overline{\text{EOP3:0}}$  pin may be connected to a dedicated external interrupt source.

A DMA operation can be suspended at any time by clearing the DMAC register channel-enable bit. It may be necessary to synchronize software to the completion of a channel's bus activity after the enable bit is cleared. This is accomplished by polling the DMA channel active bit as shown in the following assembly code segment:

```

        clrbit      0,sf2,sf2    # disable channel 0
self: bbs         4,sf2,self    # wait for channel
                                # activity to complete

```

DMA operation is restarted by setting the channel enable bit. A channel may be suspended to allow a section of time-critical user code to execute with the maximum core and bus resources available.

To reduce interrupt latency, all DMAs can be suspended when an interrupt is serviced. This option is set in the Interrupt Control (ICON) register. When the option is selected, all DMA operations are suspended during the time that the core processes the interrupt context switch. DMAs are restarted before the interrupt procedure's first instruction is encountered. This option reduces interrupt latency by providing full processor resources to the interrupt context switch.

DMA operations can be suspended by user code in an interrupt procedure to increase procedure throughput. This is accomplished by clearing the DMAC register channel enable field. See section 13.10.1, "DMA Command Register (DMAC)" (pg. 13-21). The interrupt procedure should re-enable all suspended channels before returning.

**13**

Issuing **sdma** for an active channel causes the current DMA transfer to abort. Current DMA operation is terminated and the channel is set up with the newly-issued **sdma** instruction. Do not terminate a DMA operation with **sdma**; this instruction causes a "non-graceful" termination of a DMA transfer. In other words, the transfer may be aborted between a source and destination access, potentially losing part of the source data. Additionally, status information for the terminated DMA is lost when the new **sdma** instruction reconfigures the channel. The channel done bit is not set when **sdma** terminates a DMA.

**13.9 CHANNEL PRIORITY**

Each DMA channel is assigned a priority. When more than one DMA channel is enabled, channel priority determines the order in which transfers execute for each channel. Channel priority can be programmed in one of two modes: fixed priority or rotating priority mode. The mode is selected with the priority mode bit in DMAC register.

When fixed mode is selected, each channel has a set priority. Channel 0 has the highest priority, followed by Channel 1, 2 and 3; Channel 3 has the lowest priority. In this mode, low-priority DMAs assigned to Channels 1-3 can be locked out while a time-critical DMA assigned to Channel 0 receives all of the DMA controller’s attention.

When rotating priority is selected, a channel’s priority depends on the last channel serviced (see Table 13-4). After a channel is serviced, the priority of that channel is automatically changed to the lowest channel priority. The priority of the remaining enabled channels is increased with a new channel becoming the highest priority. Rotating mode ensures that no single channel is locked out for an extended period of time.

**Table 13-4. Rotating Channel Priority**

| Last Channel Serviced | Priority |   |   |         |
|-----------------------|----------|---|---|---------|
|                       | Lowest   |   |   | Highest |
| 0                     | 0        | 3 | 2 | 1       |
| 1                     | 1        | 0 | 3 | 2       |
| 2                     | 2        | 1 | 0 | 3       |
| 3                     | 3        | 2 | 1 | 0       |

Rotating priority is useful for producing a uniform latency for every DMA channel. When rotating mode is selected, the maximum latency for a single channel is the total of all latencies associated with all enabled channels. When fixed mode is enabled, latency for any channel is dependent on the activity of all channels of higher priority.

**13.10 CHANNEL SETUP, STATUS AND CONTROL**

The DMA controller uses the DMA command register (DMAC) and setup DMA instruction (**sdma**) to configure and control the four DMA channels. The update DMA instruction (**udma**) monitors the status of an in-progress DMA operation.

The DMAC register is a special function register (sf2). This register enables or disables each channel and holds frequently-accessed status and control bits for the DMA controller, including idle or active status and termination status for a channel.



**sdma** configures each channel. **sdma** specifies source address, destination address, byte count, transfer type, chained or non-chained operation.

When a channel is set up using **sdma**, an eight-word (32-byte) block of internal data RAM is allocated for the channel. Channel state is stored in this section of data RAM when operation is preempted by another DMA channel. The user can access the current status for any active or idle DMA operation by examining data RAM assigned to a channel. This status includes the current source and destination addresses and the remaining byte count. **udma** copies the state of an active DMA channel to internal RAM.

These actions are usually taken to set up and start a DMA operation on the i960 Cx processors:

1. A channel is set up using the **sdma** instruction.
2. DMAC register is modified to enable the DMA.
3. DMAC register is then read to monitor the activity of the DMA operation.
4. **udma** can be issued and DMA data RAM examined for the current DMA status.

### 13.10.1 DMA Command Register (DMAC)

The DMA command register (Figure 13-9) is a 32-bit special function register (SFR) specified as *sf2* in assembly language. Bits 21-0 are used for DMA status and configuration; the remaining bits (bits 31-22) are reserved. These reserved bits should be programmed to zero (0) at initialization and not modified thereafter. These reserved bits are not implemented on the i960 Cx processors; clearing these bits at initialization is only required for portability to other i960 processor family products.

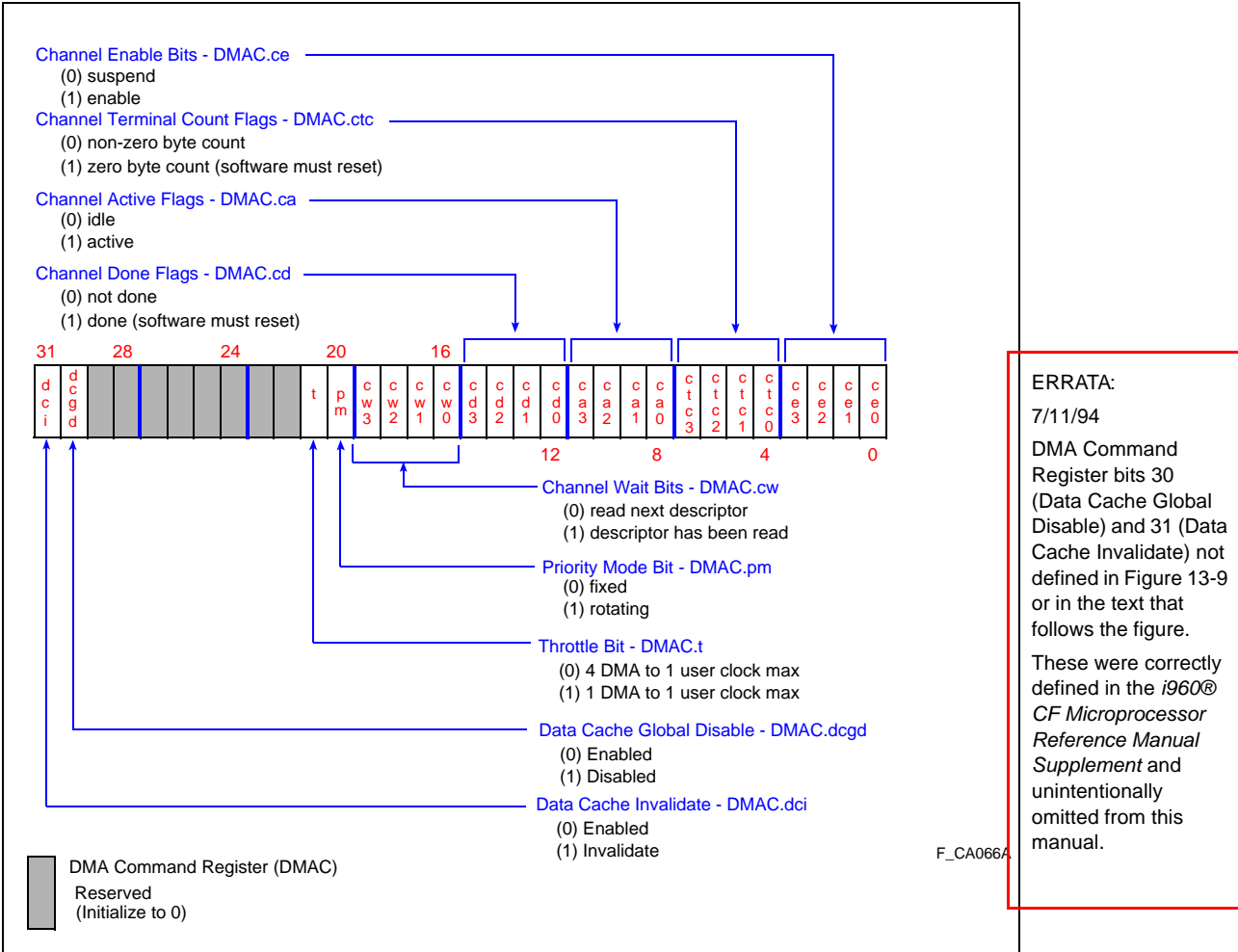


Figure 13-9. DMA Command Register (DMAC)

The *channel enable bits* (bits 3-0) enable (1) or suspend (0) a DMA after a channel is set up. Bits 0 through 3 enable or disable channels 0 through 3, respectively. If an enable bit for a channel is cleared when a channel is active, the DMA is suspended after pending DMA requests for the channel are completed and all bus activity for the pending request is complete. The channel active bits indicate the channel is suspended. DMA operation resumes at the point it was suspended when the channel enable bit is set. To ensure that a DMA channel does not start immediately after it is set up, the enable bit for the channel must be cleared by software before **sdma** is issued. This is necessary because the DMA controller does not explicitly clear the enable bit after a DMA has completed.

The *channel terminal count flags* (bits 7-4) are set when a DMA has stopped because:

- byte count has reached zero for a non-chained DMA; or
- a null pointer in a chaining descriptor is encountered in data chaining mode.

Flags 4 through 7 indicate terminal count for channels 0 through 3, respectively. A terminal count flag is set only after the last request for the channel is serviced and all bus activity for that request is complete. A channel's terminal count flag must be cleared by software before the DMA channel is enabled. This is because the DMA controller does not explicitly clear the terminal count flags after a DMA has completed — this action must be performed by software. The terminal count flags indicate status only. Modifying these bits by software has no effect on a DMA operation.

The *channel active flags* (bits 11-8) indicate that a channel is either idle (0) or active (1). Bits 8 through 11 indicate active channels 0 through 3, respectively. For demand mode, the active bit is set when the DMA request is recognized by internal hardware and remains set until all bus activity for that request is complete. In block mode, the channel active bit remains set for the duration of the block mode DMA. Channel active flags indicate status only. These flags cannot be modified by software; attempts to modify these bits by software has no effect on a DMA operation.

The *channel done flags* (bits 15-12) indicate that a channel's DMA has finished. Bits 12 through 15 indicate a completed DMA on channels 0 through 3, respectively. The DMA controller sets a channel done flag when a DMA operation has finished in one of three ways:

- byte count reached zero in a non-chaining mode
- null pointer reached in a chaining mode
- $\overline{\text{EOP3:0}}$  signal is asserted which ends the DMA operation

DMA controller channel done flags are not cleared when a channel is set up or enabled. This action must be performed by software. Channel done flags indicate status only; modifying these flags does not affect DMA controller operation.

The *channel wait bits* (bits 19-16) signal that a chaining descriptor was read and, optionally, enables a read of the next chaining descriptor in memory. Channel wait bits only enable the descriptor read when the channel is set up with the channel wait function enabled. See section 13.10.2, "Set Up DMA Instruction (sdma)" (pg. 13-24).

This function provides synchronization for programs which dynamically change chaining descriptors when a DMA is in progress. The DMA controller sets a channel wait bit when a chaining descriptor is read from memory. If the channel wait function is enabled, the DMA controller waits for the channel wait bit to be cleared by software before the next descriptor is read. See section 13.5, "DATA CHAINING" (pg. 13-13).

The *priority mode bit* (bit 20) selects fixed (0) or rotating (1) priority mode. The priority mode determines the order in which DMA channels are serviced if more than one request is pending. See section 13.9, "CHANNEL PRIORITY" (pg. 13-20).

*throttle bit* (bit 21) selects the maximum ratio of DMA process time to user process time. If the throttle bit is set, the DMA process can take up to one clock for every one clock of the user process. If the bit is clear, the DMA process can take up to four clocks for every one user process clock. The effect of the throttle bit on DMA performance is fully described in section 13.11.10, “DMA Performance” (pg. 13-36).

*Data cache global disable bit* (bit 30) controls the global enabling and disabling of the data cache. After each region is configured as either cacheable or non-cacheable through the Region Table entries, the data cache must still be globally enabled. Set this bit to 0 to enable the data cache; set to 1 to globally disable the data cache. Setting this bit only disables the data cache; it does not invalidate any of the entries. When the data cache is disabled, all loads and stores are treated as non-cacheable. Data is not written into the cache for either a load or store. After reset, the data cache is initially disabled and invalidated with this bit set to 1.

Due to implementation reasons, the data cache is not actually disabled until the second clock following execution of the instruction which sets this bit. Any load/store issued in parallel or in the clock after this instruction is still directed to the data cache. The following code can be used to dynamically disable the data cache:

```
setbit 30,sf2, sf2 # set the bit to dynamically disable data cache
mov    g0, g0     # wait two clocks before executing any code
mov    g0, g0     # which accesses the data cache
```

*Data cache invalidate bit* (bit 31) is set to invalidate the entire data cache. Setting this bit clears all valid bits in the data cache array. This provides a quick method of invalidating all the data cache. The same restrictions apply to setting the data cache invalidate bit that apply to the data cache global disable bit: the data cache is not actually disabled until the second clock following execution of the instruction which sets this bit.

The cache invalidate logic transparently manages the case where multiple pending cacheable loads are in the Bus Controller Unit (BCU) queues when the data cache is invalidated. The logic continually invalidates the data cache until all loads have returned from the BCU. This ensures that loads issued before the cache is invalidated are not written to the data cache.

The data cache invalidate bit remains set until all pending loads have returned and the cache is invalidated. At that time, the bit is cleared.

### 13.10.2 Set Up DMA Instruction (sdma)

**sdma** configures a DMA channel. The **sdma** instruction has the following format:

```
sdma  op1,          op2,          op3
        reg/lit/sfr   reg/lit/sfr   reg
```

#### ERRATA:

7/11/94

DMA Command Register bits 30 (Data Cache Global Disable) and 31 (Data Cache Invalidate) not defined in Figure 13-9 or in the text that follows the figure.

These were correctly defined in the i960® CF Microprocessor Reference Manual Supplement and unintentionally omitted from this manual.



The three operands are described in Figure 13-10 and in the following text:

- op1*: This operand is the channel number (0-3) which is set up with **sdma**. Values other than the valid channel numbers are reserved and can cause unpredictable results if used.
- op2*: This operand is the DMA control word for the channel. The control word selects the modes and options for a DMA. The value of this operand is described in section 13.10.3, “DMA Control Word” (pg. 13-25).
- op3*: This operand is used differently depending on the DMA configuration and must be a quad-aligned register (r4, r8, r12, g0, g4, g8 or g12):
- Non-chaining multi-cycle DMAs: *op3* is the first of three consecutive 32-bit registers. The first register must be programmed with byte count; the second, the source address; the third, the destination address.
  - Non-chained fly-by DMAs: *op3* is the first of two consecutive 32-bit registers. The first register must be programmed with byte count; the second, the fly-by address.
  - All chained DMAs: *op3* is a single 32-bit register. *op3* must be programmed with a pointer to the first chaining descriptor. See section 13.5, “DATA CHAINING” (pg. 13-13) for more information on chaining descriptors.

The channel setup mechanism, started with the **sdma** instruction, is two-part. **sdma** is a multi-cycle instruction. When **sdma** is issued:

1. the instruction executes — reading the register operands for the DMA operation — then completes, freeing these registers for use by other instructions.
2. a DMA setup process is triggered to complete the channel setup. The setup process runs concurrently with the execution of the user’s program.

After the setup process is started, it is possible to enable a channel through the DMAC register before the setup completes. In this case, the DMA controller waits for the setup to complete before the DMA operation begins. The result is the potential for additional latency on the first DMA request. To decrease this additional latency, issue the **sdma** instruction well in advance of enabling the DMA channel.

A second **sdma** can be issued before a previously-issued DMA setup event completes. The second **sdma** must wait for the first event to complete, preventing other instructions from executing. If the segment of code which issues the **sdma** is time-critical, it may be beneficial to overlap other operations — other than **sdma** — with the setup event and space the **sdma** instructions in the code instead of issuing them back-to-back. A waiting **sdma** instruction is interruptible; therefore, back-to-back **sdma** instructions do not adversely increase interrupt latency.

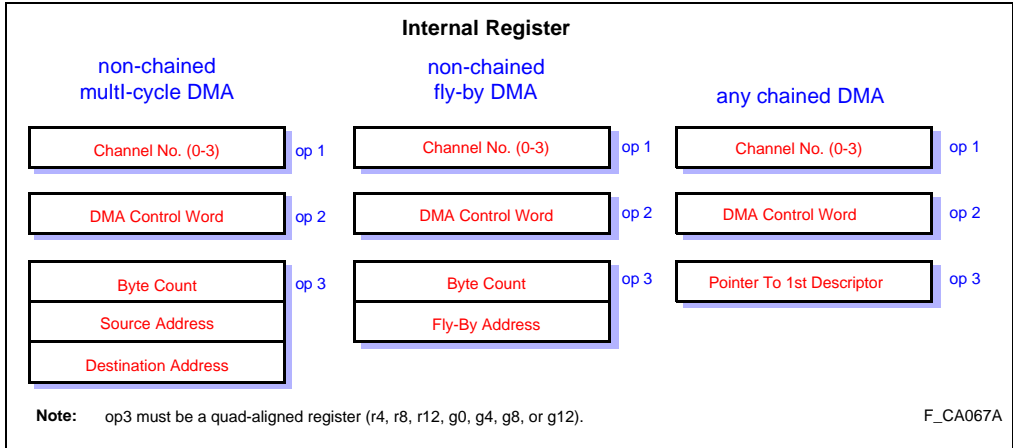


Figure 13-10. Setup DMA (sdma) Instruction Operands

### 13.10.3 DMA Control Word

DMA control word (Figure 13-11) specifies DMA modes and options. The control word is an operand (op2) of the **sdma** instruction. Paragraphs that follow the figure define the register's bit and field settings.



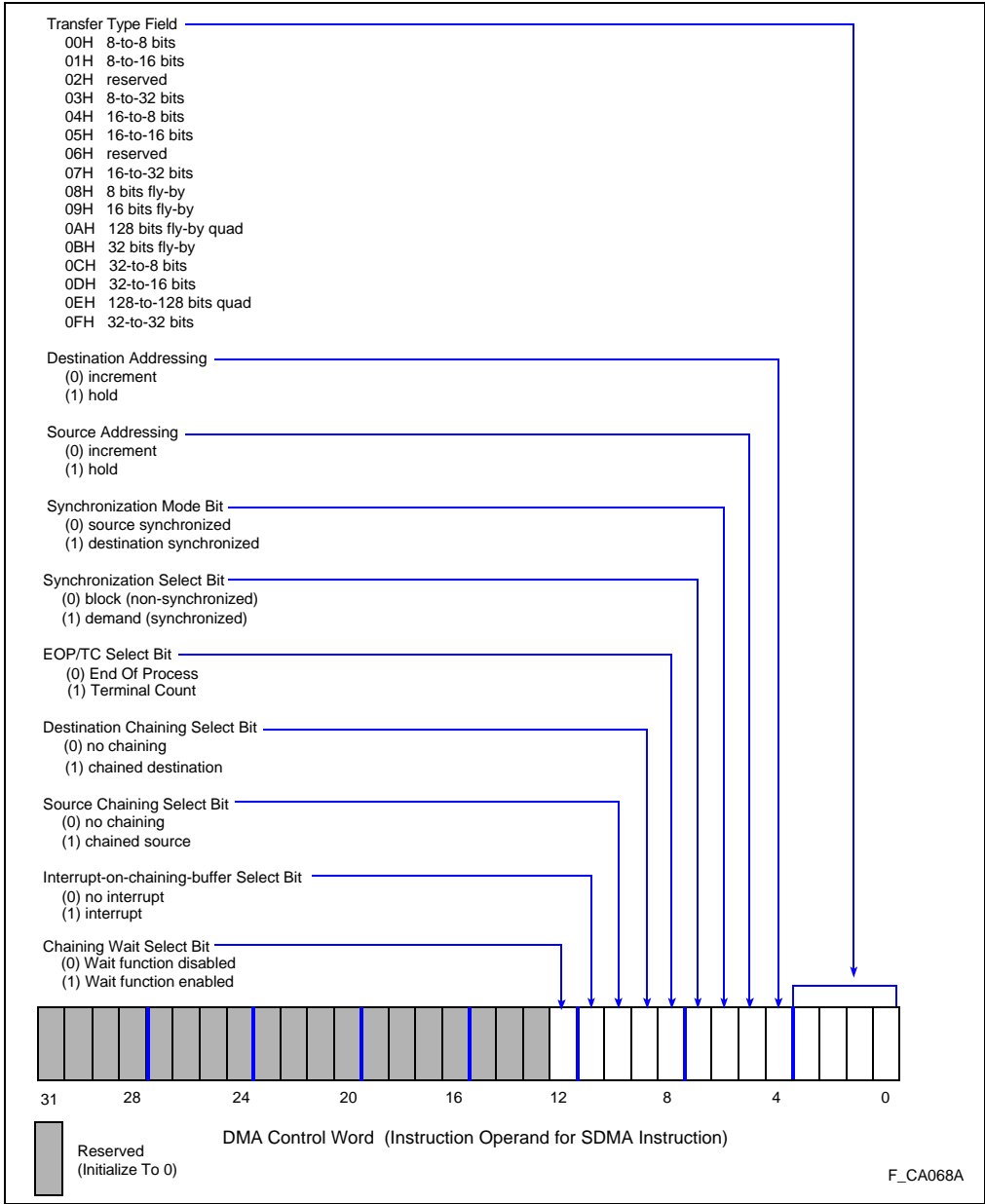


Figure 13-11. DMA Control Word

## DMA CONTROLLER

The *transfer type field* (bits 3-0) specifies the request length of bus requests issued by the DMA controller and selects between multi-cycle and fly-by transfers.

The *source/destination addressing bits* (bits 4-5) determine if the source or destination address for a channel is held fixed (1) or incremented (0) during a DMA. Bit 5 controls the source address and bit 4 controls the destination address. The source addressing bit (bit 5) controls address increment and hold for fly-by transfers.

The *synchronization mode bit* (bit 6) specifies that a multi-cycle demand mode transfer is synchronized with the source (0) or the destination (1). In fly-by mode, the bit specifies whether fly-by stores (0) or fly-by loads (1) are performed. Fly-by stores are source synchronized; fly-by loads are destination synchronized. For non-fly-by block mode transfers, this bit is ignored.

The *synchronization select bit* (bit 7) determines whether a transfer is demand (1) or block mode (0).

The *EOP/TC select bit* (bit 8) selects  $\overline{EOP/TC3:0}$  pin function. If the  $\overline{EOP/TC3:0}$  select bit is cleared (0), the pins are configured as end-of-process inputs  $\overline{EOP3:0}$ . If set (1), the pin is configured as a terminal count output  $\overline{TC3:0}$ .

The following bits in the DMA control word control data chaining. If chaining mode is not used, the source/destination chaining select bits (bits 9 and 10) must be set to 0.

The *source/destination chaining select bits* (bits 9-10) are set to enable data chaining mode. Setting bit 9 enables destination chaining; setting bit 10 enables source chaining. Setting bits 9 and 10 enables source/destination chaining. Non-chaining mode is selected if both bits are clear.

The *interrupt-on-chaining-buffer select bit* (bit 11) is set to cause an interrupt to be generated when byte count for a chained buffer reaches 0. Bit is ignored in a non-chaining mode.

The *chaining-wait select bit* (bit 12) is set to enable the channel-wait function. When the wait enable function is selected, DMAC register channel-wait bits must be cleared before a chaining descriptor is read. This channel-wait function—*together with the interrupt-on, buffer-complete function*—allows chaining descriptors to be dynamically changed during the course of a chained DMA operation. This bit is ignored when a non-chaining mode is selected. See section 13.5, “DATA CHAINING” (pg. 13-13).

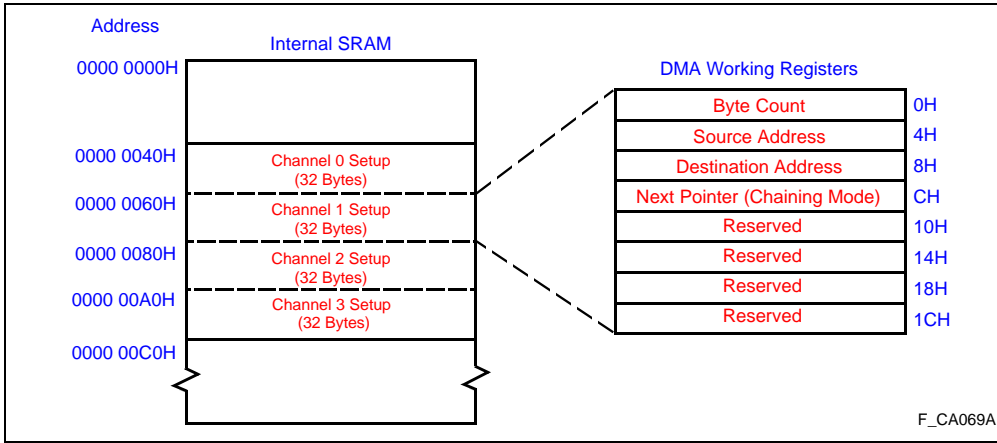
### 13.10.4 DMA Data RAM

The DMA controller uses up to 32 words of internal data RAM to swap service between active channels. When a channel is set up, the DMA controller dedicates 8 words of data RAM to that channel (see Figure 13-12). When channel service swaps from one channel to another, the active channel’s state is saved in data RAM. The state is retrieved when the channel is again serviced. DMA data RAM for a channel is only updated when service swaps to another channel or **udma** executes.



**NOTE:**

Channel swapping occurs when channel priority for a pending DMA request is higher than that of the currently active or last-serviced channel.



**Figure 13-12. DMA Data RAM**

**udma** flushes the state of a currently executing channel to data RAM. Additional DMA transfers can occur between the time that **udma** executes and a program reads the locations in data RAM. The channel may be suspended before **udma** executes to ensure coherence between the values read from data RAM and actual DMA progress.

DMA data RAM is 128 bytes of internal RAM located at 0000 0040H to 0000 00BFH (See Figure 13-12). This memory is read/write in supervisor mode and read only in user mode. This supervisor protection prevents errant modification of the DMA data RAM by a program.

DMA data RAM for any channel can be used for general purpose storage when the channel is not in use. A program, however, must not modify data RAM dedicated for a channel which is already set up and awaiting activity. In general, any modification of DMA data RAM for an active or idle channel may cause unpredictable DMA controller operation. Conversely, executing **sdma** may cause previously stored data to be overwritten in the data RAM.

## 13.10.5 Channel Setup Examples

Example 13-1. Simple Block Mode Setup

```

## Block mode setup . . .
mov      0xc,g4          # Byte count = 12
ldconst  c0_src_addr,g5 # Source address for channel 0
ldconst  c0_dest_addr,g6 # Destination addr for channel 0
ldconst  0xf,g3         # DMA ctl word (32/32 std-source
                        # inc. - dest. inc. - block)
sdma     0,g3,g4        # Setup channel 0
.
.                      # Other instructions (optional)
.
setbit   0,sf2,sf2     # enable channel 0

```

Example 13-2. Chaining Mode Setup

```

## Chaining mode setup . . .
ldconst  ptr1,g4        # Initial descriptor pointer
ldconst  0x1a6f,g3     # DMA ctl word (32/32 std-source
                        # hold-dest inc. -demand source
                        # sync.-dest. chain,channel wait,
                        # interrupt on buffer complete)
sdma     1,g3,g4       # Setup channel 1
.
.                      # Other instructions (optional)
.
setbit   1,sf2,sf2    # enable channel 1
                        # Descriptor list in memory for
                        # chaining . . .

ptr1:
        .word 0x100, b0_src_addr, b1_dest_addr, ptr3
ptr2:
        .word 0x200, 0x0, b0_dest_addr, 0x0
ptr3:
        .word 0x100, 0x0, b2_dest_addr, ptr2

```

13.11 DMA EXTERNAL INTERFACE

DMA signal characteristics  $\overline{\text{DACK3:0}}$ ,  $\overline{\text{DREQ3:0}}$ ,  $\overline{\text{EOP/TC3:0}}$  and  $\overline{\text{DMA}}$  and DMA transfer timing requirements are described in the following sections. Figure 13-13 illustrates the external interface. Refer to the i960 Cx microprocessor data sheets for AC specifications.

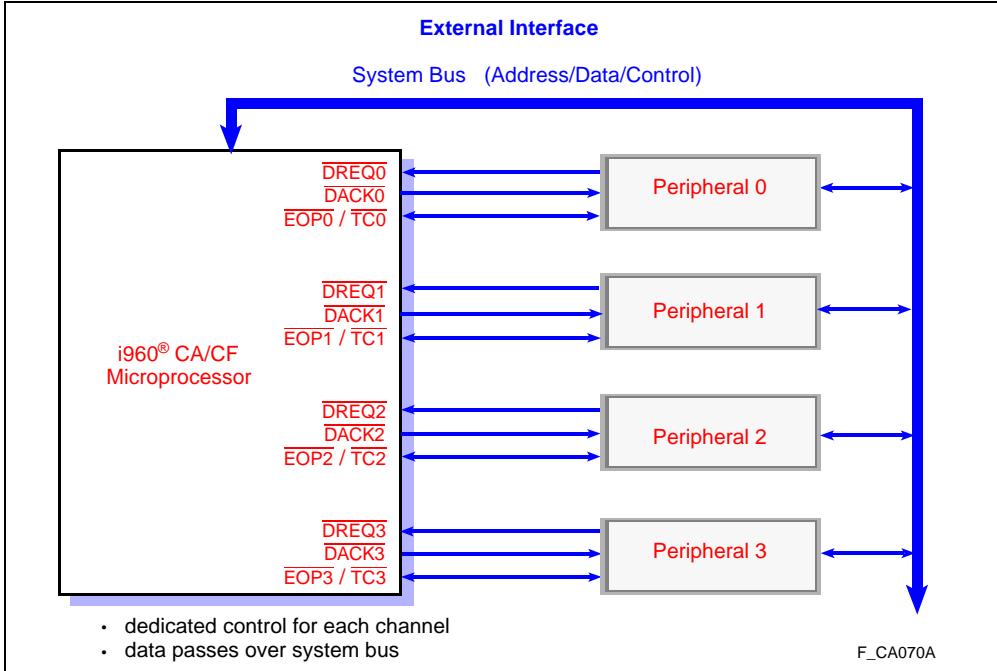


Figure 13-13. DMA External Interface

13.11.1 Pin Description

$\overline{\text{DREQ3:0}}$

**DMA Request** (input) - DMA request pins are individual, asynchronous channel-request inputs used by peripheral circuits to obtain DMA service. In fixed priority mode,  $\overline{\text{DREQ0}}$  has the highest priority;  $\overline{\text{DREQ3}}$  has the lowest priority. A request is generated by asserting the  $\overline{\text{DREQ3:0}}$  pin for a channel.

$\overline{\text{DACK3:0}}$

**DMA Acknowledge** (output) - notifies an external DMA device that a transfer is taking place. The pin is active during the bus request issued to the DMA device.

|                        |  |
|------------------------|--|
| $\overline{EOP/TC3:0}$ | <b>End of Process</b> (input $\overline{EOP3:0}$ ) or <b>Terminal Count</b> (output $\overline{TC3:0}$ ) - As an output, the pin is driven active (low) during the last transfer for a DMA and has the same timing as the $\overline{DACK3:0}$ signals. $\overline{TC3:0}$ pins are asserted when byte count reaches zero for a chained or non-chained DMA. As an input, an asynchronous active (low) signal on the pin for a minimum of two clock cycles causes DMA to terminate as described in section 13.8, “TERMINATING A DMA” (pg. 13-18). |
| $\overline{DMA}$       | <b>DMA Bus Request</b> (output) - This pin indicates that a bus request is issued by the DMA controller. The pin is active during a bus request originating from the DMA controller and inactive during all other bus requests. $\overline{DMA}$ pin value is indeterminate during idle bus cycles. The $\overline{DMA}$ pin is not active when chaining descriptors are loaded from memory.   |

### 13.11.2 Demand Mode Request/Acknowledge Timing

Demand-mode transfers require that the DMA request  $\overline{DREQ3:0}$  signal is asserted before the transfer is started. Demand mode transfers should satisfy two requirements:

1. After the transfer is requested, the DMA controller must be fast in responding to the requesting device. This characteristic is referred to as latency.
2. The requesting device must be given enough time to deassert the request signal to prevent an unwanted DMA transfer.

The timing for demand mode transfers is described in the following sections. Latency characteristics of a DMA transfer are described in section 13.11.10, “DMA Performance” (pg. 13-36).

An external device initiates a demand mode transfer by asserting (active low) one of the DMA request pins. The acknowledge pin is driven active by the DMA controller during the bus request issued to access the DMA requestor. Figure 13-14 shows  $\overline{DACK3:0}$  output timings.

To start a demand mode DMA,  $\overline{DREQ3:0}$  must be held asserted until the acknowledge bus request is started.  $\overline{EOP3:0}$  pins do not require external synchronization; however, to guarantee detection on a particular PCLK2:1 cycle, setup and hold requirements must be satisfied.

At the end of the acknowledge bus request,  $\overline{DREQ3:0}$  may be held active to initiate further DMA transfers or  $\overline{DREQ3:0}$  may be driven inactive to prevent further transfers. Depending on DMA mode, arbitration for the next DMA transfer begins:

- |         |   |
|---------|---|
| Case 1: | On the PCLK2:1 cycle in which $\overline{DACK3:0}$ is deasserted - This timing applies to demand mode fly-by transfers — and multi-cycle packing or unpacking modes — with adjacent request loads or adjacent request stores. |
| Case 2: | Two PCLK2:1 cycles after $\overline{DACK3:0}$ is deasserted - This timing applies to demand mode multi-cycle transfers with alternating request loads and stores.   |





**NOTE:**

When a DMA operation is destination-synchronized, the next load access is performed even if the request input is deasserted. This “prefetch” is implemented to increase performance. If the following DMA cycle is prevented, prefetch data is saved internally and stored when the next transfer is requested. The entire DMA cycle is not repeated.

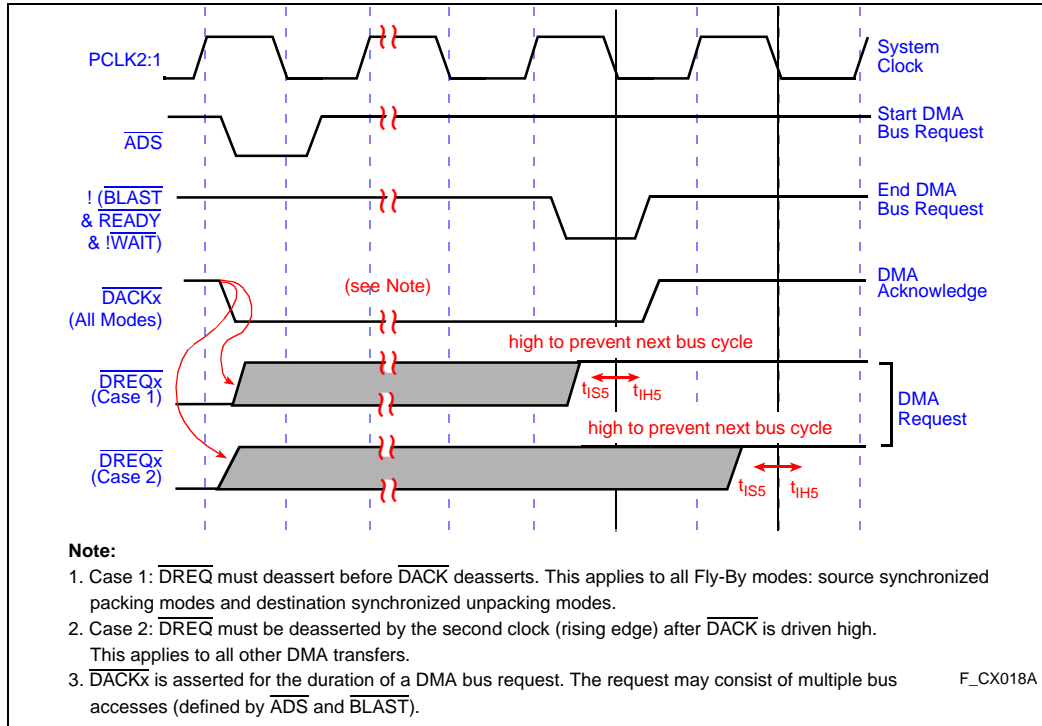


Figure 13-14. DMA Request and Acknowledge Timing

**13.11.3 End Of Process/Terminal Count Timing**

$\overline{EOP}/\overline{TC3:0}$  can be programmed as an input  $\overline{EOP3:0}$  or output  $\overline{TC3:0}$  for each channel.  $\overline{EOP}/\overline{TC3:0}$  pins are configured when a channel is setup using `sdma`.

$\overline{TC3:0}$  is asserted when byte count reaches zero (0) for a chained or non-chained DMA. A  $\overline{TC3:0}$  pin for a channel is driven active during the last acknowledge bus request for a non-chained DMA or during the last acknowledge bus request of each buffer for a chained DMA.  $\overline{TC3:0}$  pins have the same timing as  $\overline{DACK3:0}$ .



$\overline{EOP3:0}$  pins are asserted to terminate a DMA.  $\overline{EOP3:0}$  pins are active-level detected. For proper internal detection,  $\overline{EOP3:0}$  pins must be asserted for a minimum of two and maximum of 17 PCLK2:1 cycles (See Figure 13-15).  $\overline{EOP3:0}$  pins do not require external synchronization; however, to guarantee detection on a particular PCLK2:1 cycle, setup and hold requirements must be satisfied. The maximum pulse width requirement for the  $\overline{EOP3:0}$  pin is to prevent more than one buffer transfer to terminate in the source/destination chaining mode.  $\overline{EOP3:0}$  inputs adhere to the same timing requirements as  $\overline{DREQ3:0}$  for arbitration of the next DMA transfer.

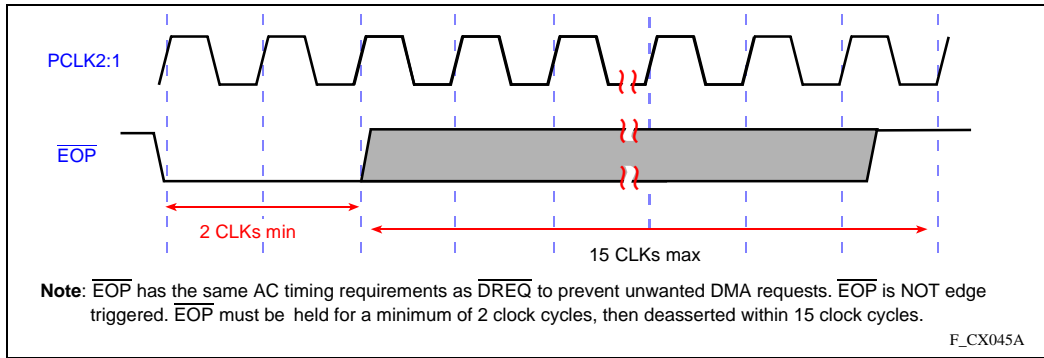


Figure 13-15.  $\overline{EOP3:0}$  Timing

#### 13.11.4 Block Mode Transfers

Block mode DMAs require no synchronization with a source or a destination device.  $\overline{DREQ3:0}$  inputs are ignored during block mode DMAs. The acknowledge signal  $\overline{DACK3:0}$  is driven active when the source is accessed.  $\overline{EOP/TC3:0}$  pins have the same function as described in section 13.11.3, “End Of Process/Terminal Count Timing” (pg. 13-32).

#### 13.11.5 DMA Bus Request Pin

The DMA request pin  $\overline{DMA}$  indicates that the DMA controller initiated a bus access. The pin is asserted (low) for any DMA load or store bus request.  $\overline{DMA}$  is deasserted (high) for other bus requests. The  $\overline{DMA}$  pin has the same timing as the  $\overline{W/R}$  pin. The  $\overline{DMA}$  pin is not active when chaining descriptors are fetched from memory.



### 13.11.6 DMA Controller Implementation

The i960 Cx processors' DMA functions are implemented primarily in microcode. Processor clock cycles are required to setup and execute a DMA operation. DMA features — including data chaining, data alignment, byte assembly and disassembly — are implemented in microcode. DMA hardware arbitrates channel requests, handles the DMA external hardware interface and interfaces to microcode for most efficient use of core resources.

When considering whether to use the DMA controller, two questions generally arise:

1. When a DMA transfer is executing, how many internal processor clock cycles does the DMA operation consume?
2. When a DMA transfer is executing, how much of the total bus bandwidth is consumed by the DMA bus operations?

These questions are addressed in the following sections.

### 13.11.7 DMA and User Program Processes

The i960 Cx processors allow DMA operations to be executed in microcode while providing core bandwidth for the user's program. This sharing of core resources is accomplished by implementing separate hardware processes for each DMA channel and for the user's program. Alternating between the DMA and the user process enables the user code and up to four DMA processes (one per channel) to run concurrently.

The environments for the DMA and user processes are implemented entirely in internal hardware, as well as the mechanism for switching between processes. This hardware implementation enables the i960 Cx processors to switch processes on clock boundaries; no instruction overhead is necessary to switch the process. With this switching mechanism, DMA microcode and the user program can frequently alternate execution with absolutely no performance loss caused by the process switching.

A process switch from user process to DMA process occurs as a result of a DMA event. A DMA event is signaled when a DMA channel requires service or is in the process of setting up a channel. Signaling the DMA event is controlled by DMA logic.

After a DMA event is signaled, the DMA process takes a certain number of clock cycles and then the user process is restored. The maximum ratio of DMA-to-user cycles is 4:1. This means that, at most, the DMA process takes four clock cycles to every single-user process clock. The ratio of DMA to user cycles can also be selected as 1:1 to increase execution speed of the user process while a DMA is in progress. The user-to-DMA cycle ratio is controlled by the throttle bit in the DMA command register (DMAC.t).

A DMA rarely uses the maximum available cycles for the DMA process. Actual cycle allocation between user process and DMA process depends on the type of DMA operation performed, DMA channel activity and external bus loading and performance. Maximum allocation of internal processor clocks to DMA processes are specified in section 13.11.10, “DMA Performance” (pg. 13-36).

**13.11.8 Bus Controller Unit**

The bus controller unit (BCU) accesses memory and devices which are source and destination of a transfer. When the DMA process is active, DMA microcode issues load or store requests to the bus controller to perform DMA data transfers. The DMA and user processes equally share access to the bus on a request-by-request basis. If both processes attempt to flood the bus controller with memory requests, the bus is shared equally; this prevents lockout of either process. If either process does require the bus, the bus controller resource may be used entirely by either process.

The BCU contains a queue which accepts up to three pending requests for bus transactions (Figure 13-16). When a DMA channel is set up, the queue is divided such that one slot is dedicated for DMA process requests and two slots are dedicated for user process requests. DMA and core entries are arranged in such a way that when both a user and DMA slot are filled, bus request servicing alternates between requests issued by the user and DMA processes.

**13.11.9 DMA Controller Logic**

DMA controller logic manages the execution of DMA operations independently from the core. It:

- Synchronizes DMA transfers with external request/acknowledge signals.
- Provides the program interface to set up each of the four DMA channels.
- Provides the program interface to monitor the status of the four channels.
- Arbitrates requests between multiple DMA channels by managing channel priority.
- Produces the DMA event which causes DMA microcode to execute.



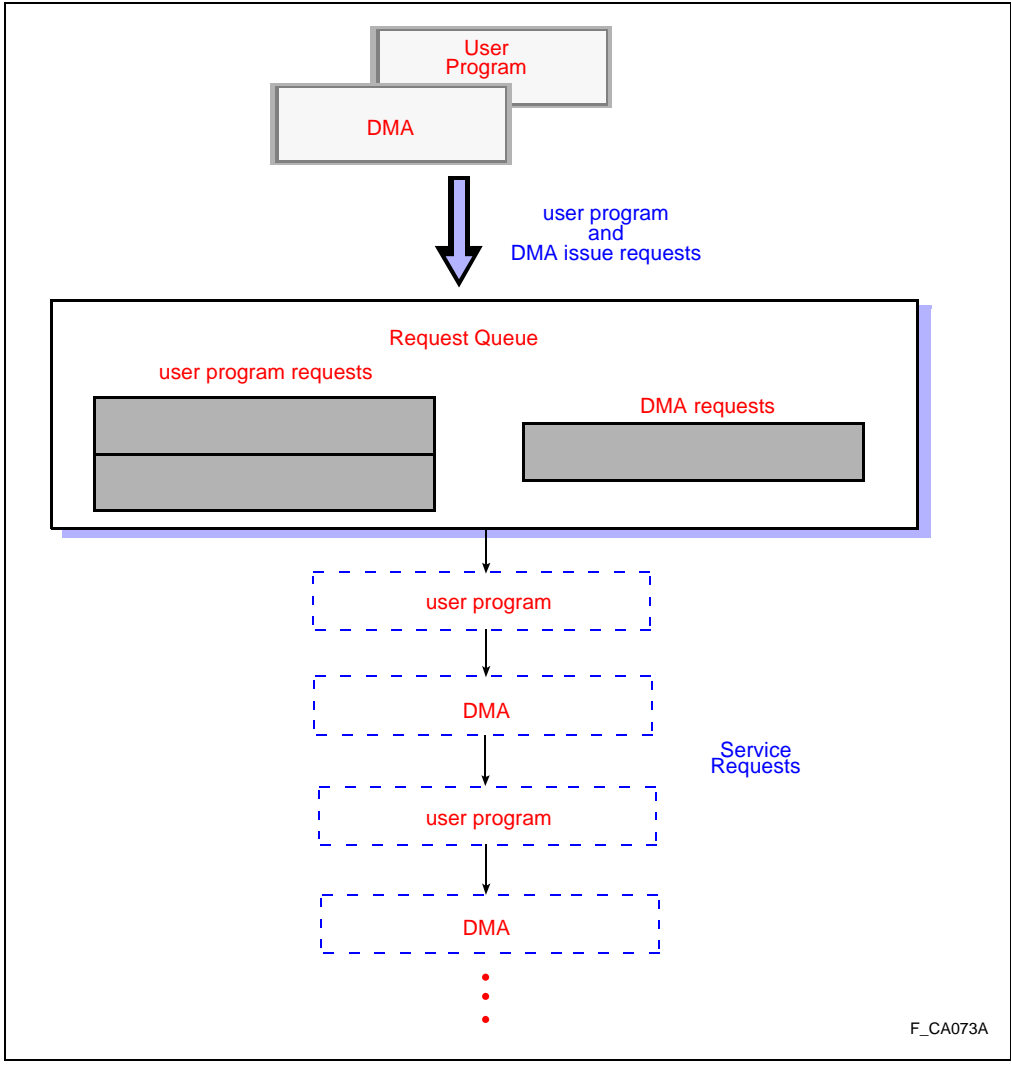


Figure 13-16. DMA and User Requests in the Bus Queue

### 13.11.10 DMA Performance

DMA performance is characterized by two values: throughput and latency (Figure 13-17). Throughput measurement is needed as a measure of the DMA transfer bandwidth. Worst-case latency is required to determine if the DMA is fast enough in responding to transfer requests from DMA devices.



Throughput describes how fast data is moved by DMA operations. In this discussion, throughput is the measure of how often DMA requests are serviced. DMA throughput, denoted as  $N_{TREQ}$ , is measured in PCLK2:1 clocks per DMA request. As Figure 13-17 shows,  $N_{TREQ}$  is the time measured between adjacent assertions of  $\overline{DACK3:0}$ . The established measure of throughput, in units of bytes/second, is derived with the following equation:

$$\text{Throughput (bytes/second)} = \left( \frac{B_{REQ} \times f_C}{N_{TREQ}} \right) \quad \text{Equation 13-1}$$

where:

$N_{TREQ}$  = throughput clocks per DMA request (PCLK2:1 cycles)

$B_{REQ}$  = bytes per DMA request

$f_C$  = PCLK2:1 frequency

Latency is defined as the maximum time delay measured between the assertion of  $\overline{DREQ3:0}$  and the assertion of the corresponding  $\overline{DACK3:0}$  pin. In this section, latency is derived in number of PCLK2:1 cycles. This value is denoted by the symbol  $N_{LATENCY}$ . The established measure of DMA latency, in units of seconds, is derived with this equation:

$$\text{DMA Latency (seconds)} = \frac{N_{LATENCY}}{f_C} \quad \text{Equation 13-2}$$

where:

$N_{LATENCY}$  = Latency (PCLK2:1 cycles)

$f_C$  = PCLK2:1 frequency



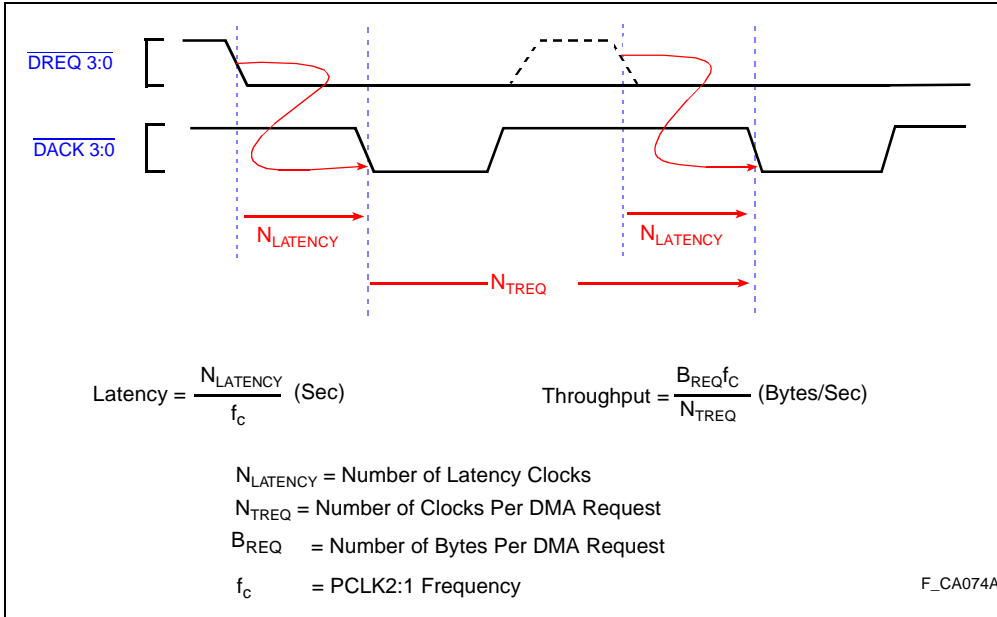


Figure 13-17. DMA Throughput and Latency

### 13.11.11 DMA Throughput

DMA throughput ( $N_{\text{TREQ}}$ ) for a particular system is governed by the following factors:

- DMA transfer type
- Memory system configuration
- Bus activity generated by the user process
- DMA throttle bit value

$N_{\text{TREQ}}$  is derived from the transfer clocks ( $N_{\text{XFER}}$ ) provided in Table 13-5. Values in this table are derived assuming:

- No bus activity is generated by the user process.
- DMA transfer source and destination memory are zero wait states or internal data RAM.

Table 13-5 provides the number of PCLK2:1 cycles required for each unit DMA transfer. Transfer clock values, denoted by the symbol  $N_{\text{XFER}}$ , are provided in the two boldface columns. These columns show transfer clocks for the DMA throttle bit set to 1:1 and 4:1 configuration. Transfer clocks are given in pairs separated by a “/”: the number on the left is the value for source synchronized demand mode transfers; the number on the right is the value for destination synchronized demand mode transfers.

## DMA CONTROLLER

Table 13-5 also shows the number of bytes per transfer. This is the number of bytes which are transferred in  $N_{XFER}$  clock cycles. Bytes per transfer is denoted by the symbol  $B_{XFER}$ . DMA throughput ( $N_{TREQ}$ ) is calculated as shown in Equation 13-3.

$$N_{TREQ} = N_{XFER} * \left( \frac{B_{REQ}}{B_{XFER}} \right) \quad \text{Equation 13-3}$$

where:

- $N_{XFER}$  = number of PCLK2:1 cycles per transfer
- $B_{REQ}$  = number of bytes transferred per DMA request
- $B_{XFER}$  = number of bytes per DMA transfer

**Table 13-5. DMA Transfer Clocks -  $N_{XFER}$**

|   |   | Transfer Clocks<br>$N_{XFER}$ in PCLK2:1 cycles<br>(Source Sync./Destination Sync.) |                 |            |                 |            |
|---|---|---|-----------------|------------|-----------------|------------|
| Transfer Type<br>(source-to-destination<br>data length) | Bytes per<br>Transfer<br>( $B_{XFER}$ ) | DMA<br>Process  | Throttle = 4:1  |            | Throttle = 1:1  |            |
|   |   |   | User<br>Process | $N_{XFER}$ | User<br>Process | $N_{XFER}$ |
| 8-to-8 Multi-Cycle                                      | 1                                       | 4/4   | 6/6             | 10/10      | 7/7             | 11/11      |
| 8-to-16 Multi-Cycle                                     | 2                                       | 11/11   | 10/11           | 21/22      | 18/19           | 29/30      |
| 8-to-32 Multi-Cycle                                     | 4                                       | 23/25   | 16/15           | 39/40      | 30/29           | 53/54      |
| 16-to-8 Multi-Cycle                                     | 2                                       | 10/10   | 8/8             | 18/18      | 14/13           | 24/23      |
| 16-to-16 Multi-Cycle                                    | 2                                       | 4/4   | 6/6             | 10/10      | 7/7             | 11/11      |
| 16-to-32 Multi-Cycle                                    | 4                                       | 9/12  | 11/8            | 20/20      | 17/14           | 26/26      |
| 32-to-8 Multi-Cycle                                     | 4                                       | 22/22   | 13/13           | 35/35      | 26/23           | 48/45      |
| 32-to-16 Multi-Cycle                                    | 2                                       | 10/11   | 8/8             | 18/19      | 14/13           | 24/24      |
| 32-to-32 Multi-Cycle (aligned)                          | 4                                       | 4/4   | 6/6             | 10/10      | 7/7             | 11/11      |
| 32-to-32 Multi-Cycle<br>(unaligned)                     | 4                                       | 6/6   | 6/6             | 12/12      | 9/9             | 15/15      |
| 128-to-128 Multi-Cycle                                  | 16                                      | 6/7   | 9/9             | 15/16      | 10/10           | 16/17      |
| 8-bit Fly-by  | 1                                       | 3/3   | 3/3             | 6/6        | 4/4             | 7/7        |
| 16-bit Fly-by   | 2                                       | 3/3   | 3/3             | 6/6        | 4/4             | 7/7        |
| 32-bit Fly-by   | 4                                       | 3/3   | 3/3             | 6/6        | 4/4             | 7/7        |
| 128-bit Fly-by  | 16                                      | 3/3   | 6/6             | 9/9        | 6/6             | 9/9        |

The columns in Table 13-5 labeled *DMA Process* and *User Process* show the number of clock cycles allocated to either these processes during a single DMA transfer. Equation 13-4 provides the minimum fraction of processor bandwidth remaining for the user process during a DMA transfer.





$$\text{Minimum User Process Bandwidth} = \frac{\text{UserProcessClocks}}{N_{\text{XFER}}} * 100\% \quad \text{Equation 13-4}$$

Transfer types that do not perform assembly or disassembly always have  $N_{\text{TREQ}}$  equal to  $N_{\text{XFER}}$ . For example,  $B_{\text{XFER}}$  for a 32 to 32 bit multi-cycle transfer has a value of 4, which means that each transfer moves 4 bytes.  $B_{\text{REQ}}$  is 4 which indicates that 4 bytes of data is transferred every DMA request. This means that every DMA request will cause a transfer. Throughput per DMA request ( $N_{\text{TREQ}}$ ), found by using Equation 13-3, is equal to  $N_{\text{XFER}}$ ; 10 clocks.

In some cases a transfer does not occur every DMA request. For example, a source synchronized 8-to-32 bit transfer requires 4 DMA requests before the transfer is complete. In this case  $B_{\text{XFER}}=4$ ,  $N_{\text{XFER}}=39$  clocks, but  $B_{\text{REQ}}=1$ .  $B_{\text{REQ}}=1$  because the source of this source-synchronized transfer is only 8 bits (1 byte) wide. This leads to a  $N_{\text{TREQ}}$  of  $39/4$  clocks. By changing this example from source-synchronized to destination-synchronized,  $N_{\text{TREQ}}$  becomes 39 clocks. This is due to the fact that the destination is 32 bits (4 bytes) wide, and a complete transfer occurs every DMA request.

### 13.11.12 DMA Latency

DMA latency in a system depends on the following factors:

- DMA transfer type and subsequently the worst-case throughput value calculated for that transfer
- Number of channels enabled and the priority of the requesting channel
- Status of the suspend DMA on interrupt bit in the Interrupt Control register (ICON.dmas)

DMA latency is the sum of the worst-case throughput for the channel plus added components which are dependent on the configuration of the DMA controller. DMA latency is denoted as  $N_{\text{LATENCY}}$  in the following discussion and is measured in number of PCLK2:1 cycles.

Table 13-6 shows the values for worst-case throughput.  $N_{\text{TREQ}}$ ,  $N_{\text{T\_first}}$  and  $N_{\text{T\_chain}}$  describe DMA throughput.  $N_{\text{TREQ}}$ , derived in Equation 13-3, describes the average DMA throughput, measured for a transfer which is in progress.  $N_{\text{T\_first}}$  and  $N_{\text{T\_chain}}$  represent boundary conditions of throughput for the following conditions:

First DMA transfer in non-chained modes —  $N_{\text{T\_first}}$  is the throughput of the first transfer of a non-chained DMA operation. After the setup microcode completes, additional microcode is required to start the first DMA transfer.

## DMA CONTROLLER

First DMA transfer of a chained DMA buffer —  $N_{T\_chain}$  is the throughput between chained buffers (chaining mode only). The time required to arbitrate another buffer transfer in chaining mode, read the next chaining descriptor from memory and acknowledge the first transfer of the new buffer. Two values are given in Table 13-6 for  $N_{T\_chain}$  to account for differences in throughput for EOP chaining mode. EOP chaining occurs when the DMA controller is configured for both source and destination chaining, the  $\overline{EOP/TC3:0}$  pins are configured as inputs and  $\overline{EOP3:0}$  is asserted by the external system to cause chaining to the next buffer transfer.

$N_{T\_first}$  and  $N_{T\_chain}$  are calculated as shown in Equations 13-5 and 13-6.

$$N_{T\_first} = [N_{T0\_first} + N_{T0\_first} * (0.6 * throttle)] \quad \text{Equation 13-5}$$

$$N_{T\_chain} = [N_{T0\_chain} + N_{T0\_first} * (0.6 * throttle)] \quad \text{Equation 13-6}$$

where:

throttle = 0 for 4:1 throttle mode; 1 for 1:1 throttle mode

The factor of 0.6 is used to characterize the effect on the worst-case base throughput value of disabling the throttle mode. For determination of  $N_{TREQ}$ , Table 13-5 provides separate measurements with the throttle bit both enabled and disabled.



Table 13-6. Base Values of Worst-case DMA Throughput used for DMA Latency Calculation

| Transfer Type<br>(source-to-dest. data length) | Base worst-case throughput per request (PCLK2:1 cycles)<br>(Source Synchronized/Destination Synchronized) |                                   |                                     |
|--|---|-----------------------------------|-------------------------------------|
|  | N <sub>T0_first</sub>   | N <sub>T0_chain</sub><br>(no EOP) | N <sub>T0_chain</sub><br>(with EOP) |
| 8-to-8 Multi-Cycle                             | 15/22   | 61/63                             | 85/84                               |
| 8-to-16 Multi-Cycle                            |   |                                   |                                     |
| aligned  | 17/32   | 63/71                             | 95/92                               |
| unaligned                                      | 20/32   | 62/69                             | 98/92                               |
| 8-to-32 Multi-Cycle                            |   |                                   |                                     |
| aligned  | 18/53   | 63/90                             | 96/113                              |
| unaligned                                      | 18/53   | 60/90                             | 96/113                              |
| 16-to-8 Multi-Cycle                            |   |                                   |                                     |
| aligned  | 20/23   | 69/62                             | 108/81                              |
| unaligned                                      | 20/23   | 62/60                             | 108/81                              |
| 16-to-16 Multi-Cycle                           |   |                                   |                                     |
| aligned  | 20/24   | 90/89                             | 114/112                             |
| unaligned                                      | 35/50   | 112/117                           | 129/138                             |
| 16-to-32 Multi-Cycle                           |   |                                   |                                     |
| aligned  | 35/42   | 104/103                           | 150/127                             |
| unaligned                                      | 55/73   | 123/136                           | 170/158                             |
| 32-to-8 Multi-Cycle                            |   |                                   |                                     |
| aligned  | 21/25   | 92/64                             | 87/83                               |
| unaligned                                      | 21/28   | 63/65                             | 87/86                               |
| 32-to-16 Multi-Cycle                           |   |                                   |                                     |
| aligned  | 20/26   | 93/89                             | 110/110                             |
| unaligned                                      | 52/66   | 120/129                           | 142/150                             |
| 32-to-32 Multi-Cycle                           |   |                                   |                                     |
| aligned  | 24/33   | 92/74                             | 94/95                               |
| unaligned                                      | 30/52   | 118/93                            | 114/114                             |
| 128-to-128 Multi-Cycle                         | 19/29   | 63/68                             | 67/75                               |
| 8-bit Fly-by                                   | 27/27   | 59/59                             | 88/80                               |
| 16-bit Fly-by                                  | 27/27   | 59/59                             | 88/80                               |
| 32-bit Fly-by                                  | 27/27   | 59/59                             | 88/80                               |
| 128-bit Fly-by                                 | 27/27   | 59/59                             | 88/80                               |

13

Additional components of worst-case DMA latency depend on DMA controller configuration. These components are defined in Table 13-7 and their values are given in Table 13-8.



**Table 13-7. DMA Latency Components**

|                    |                         |   |
|--------------------|-------------------------|---|
| $N_{\text{setup}}$ | Set up DMA channel      | Describes the time required for microcode to complete channel setup after <b>sdma</b> executes. This latency component may be ignored if the channel is enabled $N_{\text{setup}}$ clock cycles after <b>sdma</b> is executed.                        |
| $N_{\text{swap}}$  | Swap DMA channel        | Time required for a higher priority channel to preempt a lower priority channel and the time required to copy the associated DMA working registers to internal data RAM. If only one channel is enabled in a system, then $N_{\text{swap}}$ equals 0. |
| $N_{\text{lower}}$ | Lower Priority Channels | Latency of lower priority channels which are preempted when a DMA for the highest priority channel is requested. A transfer on the lower priority channel must complete before the higher priority channel is serviced.                               |
| $N_{\text{int}}$   | Interrupt Latency       | Latency caused by servicing an interrupt with the suspend DMA mode enabled. $N_{\text{int}}$ is the same as the worst case interrupt latency for the system.  |

**Table 13-8. Values of DMA Latency Components**

| Latency Component  | Condition   | Value (PCLK2:1 Cycles)       | Notes |
|--------------------|---|------------------------------|-------|
| $N_{\text{setup}}$ | Non-chained DMA modes   | 36                           |       |
|                    | Chained DMA modes   | 44                           |       |
|                    | Channel enable delayed from <b>sdma</b> execution by > 36 clock cycles in non-chaining mode or > 44 clock cycles in a chained DMA mode. | 0                            |       |
| $N_{\text{swap}}$  | Single DMA channel enabled - No channel preemption  | 0                            |       |
|                    | Multiple DMA channels enabled - Preempt lower priority channels   | 5*(# of channels preempted)  |       |
| $N_{\text{lower}}$ | Single DMA channel enabled - No channel preemption  | 0                            |       |
|                    | Multiple DMA channels enabled - Preempt lower priority channel  | $N_L'$                       | (1)   |
| $N_{\text{int}}$   | DMA suspend on interrupt disabled   | 0                            |       |
|                    | DMA suspend on interrupt enabled  | Worst-case Interrupt Latency |       |

**NOTES:**

- $N_L'$  is the sum of maximum latencies of all channels which may be preempted by the requesting channel. For example, with four DMA channels enabled and rotating priority mode, a channel request may be required to preempt three other channels with pending requests. In this case, the  $N_L'$  component is the sum of all of these latencies.



As shown in Equations 13-7 and 13-8, worst-case DMA latency is finally calculated as the sum of the individual latency components plus the worst-case throughput condition:

*Non-chaining modes:*

$$N_{\text{LATENCY (worst case)}} = \max(N_T, N_{T\_first}) + N_{\text{setup}} + N_{\text{swap}} + N_{\text{lower}} + N_{\text{int}} \quad \text{Equation 13-7}$$

*Chaining modes:*

$$N_{\text{LATENCY (worst case)}} = N_{T\_chain} + N_{\text{setup}} + N_{\text{swap}} + N_{\text{lower}} + N_{\text{int}} \quad \text{Equation 13-8}$$



INITIALIZATION AND SYSTEM  
REQUIREMENTS







## CHAPTER 14

# INITIALIZATION AND SYSTEM REQUIREMENTS

This chapter describes the steps that the i960<sup>®</sup> Cx processors take during initialization. Discussed are the  $\overline{\text{RESET}}$  pin, the reset state, built-in self test (BIST) features and on-circuit emulation function (ONCE). The chapter also describes the processor's basic system requirements — including power, ground and clock — and concludes with some general guidelines for high-speed circuit board design.

### 14.1 OVERVIEW

During the time that the  $\overline{\text{RESET}}$  pin is asserted, the processor is in a quiescent reset state. All external pins are inactive and the internal processor state is forced to a known condition. The processor begins initialization when the  $\overline{\text{RESET}}$  pin is deasserted.

When initialization begins, the processor uses an Initial Memory Image (IMI) to establish its state. The IMI includes:

- Initialization Boot Record (IBR) – contains the addresses of the first instruction of the user's code and the PRCB.
- Process Control Block (PRCB) – contains pointers to system data structures; also contains information used to configure the processor at initialization.
- System data structures – several data structure pointers are cached internally at initialization.

The i960 Cx processors may be reinitialized by software. When a reinitialization takes place, a new PRCB and reinitialization instruction pointer are specified. Reinitialization is useful for relocating data structures from ROM to RAM after initialization.

The processor supports several facilities to assist in system testing and startup diagnostics. The ONCE mode electrically removes the processor from a system. This feature is useful for system-level testing where a remote tester exercises the processor system. During initialization, the processor performs an internal functional self test and external bus self test. These features are useful for system diagnostics to ensure basic CPU and system bus functionality.

The processor is designed to minimize the requirements of its external system. The processor requires an input clock (CLKIN) and clean power and ground connections ( $V_{SS}$  and  $V_{CC}$ ). Since the processor can operate at a high frequency, the external system must be designed with considerations to reduce induced noise on signals, power and ground.

## 14.2 INITIALIZATION

Initialization describes the mechanism that the processor uses to establish its initial state and begin instruction execution. Initialization begins when  $\overline{\text{RESET}}$  is deasserted. At this time, the processor automatically configures itself with information specified in the IMI and performs its built-in self test. The processor then branches to the first instruction of user code.

The objective of the initialization sequence is to provide a complete, working initial state when the first user instruction executes. The user's startup code has only to perform several base functions to place the processor in a configuration for executing application code.

### 14.2.1 Reset Operation

The  $\overline{\text{RESET}}$  pin, when asserted (active low), causes the processor to enter the reset state. All external signals go to a defined state (Table 14-1); internal logic is initialized; and certain registers are set to defined values (Table 14-2). When the  $\overline{\text{RESET}}$  pin is deasserted, the processor begins initialization as described later in this chapter.  $\overline{\text{RESET}}$  is a level-sensitive, asynchronous input.

The  $\overline{\text{RESET}}$  pin must be asserted when power is applied to the processor. The processor then stabilizes in the reset state. This power-up reset is referred to as *cold reset*. To ensure that all internal logic has stabilized in the reset state, a valid input clock (CLKIN) and  $V_{CC}$  must be present and stable for a specified time before  $\overline{\text{RESET}}$  can be deasserted.

The processor may also be cycled through the reset state after execution has started. This is referred to as *warm reset*. For a warm reset, the  $\overline{\text{RESET}}$  pin must be asserted for a minimum number of clock cycles. Specifications for a cold and warm reset can be found in the i960 CA/CF microprocessor data sheets.

The reset state cannot be entered under direct control from a program. No reset instruction — or other condition which forces a reset — exists on the i960 Cx processors. The  $\overline{\text{RESET}}$  pin must be asserted to enter the reset state. The processor does, however, provide a means to reenter the initialization process. See section 14.3.1, “Reinitializing and Relocating Data Structures” (pg. 14-11).



Table 14-1. Pin Reset State

| Pins <sup>(1)</sup>       | Reset State     | Pins <sup>(1)</sup>         | Reset State      |
|---------------------------|-----------------|-----------------------------|------------------|
| A31:2                     | Floating        | $\overline{\text{DMA}}$     | Floating         |
| D31:0                     | Floating        | $\overline{\text{SUP}}$     | Floating         |
| $\overline{\text{BE3:0}}$ | High (inactive) | $\overline{\text{FAIL}}$    | Low (active)     |
| $\overline{\text{W/R}}$   | Low (read)      | $\overline{\text{DACK3}}$   | High (inactive)  |
| $\overline{\text{ADS}}$   | High (inactive) | $\overline{\text{DACK2}}$   | High (inactive)  |
| $\overline{\text{WAIT}}$  | High (inactive) | $\overline{\text{DACK1}}$   | High (inactive)  |
| $\overline{\text{BLAST}}$ | High (inactive) | $\overline{\text{DACK0}}$   | High (inactive)  |
| $\overline{\text{DT/R}}$  | Low (receive)   | $\overline{\text{EOP/TC3}}$ | Floating (input) |
| $\overline{\text{DEN}}$   | High (inactive) | $\overline{\text{EOP/TC2}}$ | Floating (input) |
| $\overline{\text{LOCK}}$  | High (inactive) | $\overline{\text{EOP/TC1}}$ | Floating (input) |
| $\overline{\text{BREQ}}$  | Low (inactive)  | $\overline{\text{EOP/TC0}}$ | Floating (input) |
| $\overline{\text{D/C}}$   | Floating        |                             |                  |

**NOTE:**

(1) Pin states shown assume HOLD and  $\overline{\text{ONCE}}$  pins are not asserted. If HOLD is asserted during reset, the hold is acknowledged by asserting HOLDA and the processor pins are configured in the Hold Acknowledge state (See CHAPTER 10, THE BUS CONTROLLER.) If the  $\overline{\text{ONCE}}$  pin is asserted, the processor pins are all floated.

Table 14-2. Register Values After Reset

| Register <sup>(1)</sup> | Value after cold reset   | Value after warm reset   |
|-------------------------|--------------------------|--------------------------|
| AC                      | AC initial image in PRCB | AC initial image in PRCB |
| PC                      | C01F2002H                | C01F2002H                |
| TC                      | TC initial image in PRCB | TC initial image in PRCB |
| FP (g15)                | interrupt stack base     | interrupt stack base     |
| PFP (r0)                | undefined                | undefined                |
| SP (r1)                 | interrupt stack base+64  | interrupt stack base+64  |
| RIP (r2)                | undefined                | undefined                |
| IPND (sf0)              | undefined                | value before warm reset  |
| IMSK (sf1)              | 00H                      | 00H                      |
| DMAC (sf2)              | 00H                      | 00H                      |

**NOTE:**

(1) All control registers (not listed) are configured with their respective values from the control table after reset.

**14.2.2 Self Test Function (STEST,  $\overline{\text{FAIL}}$ )**

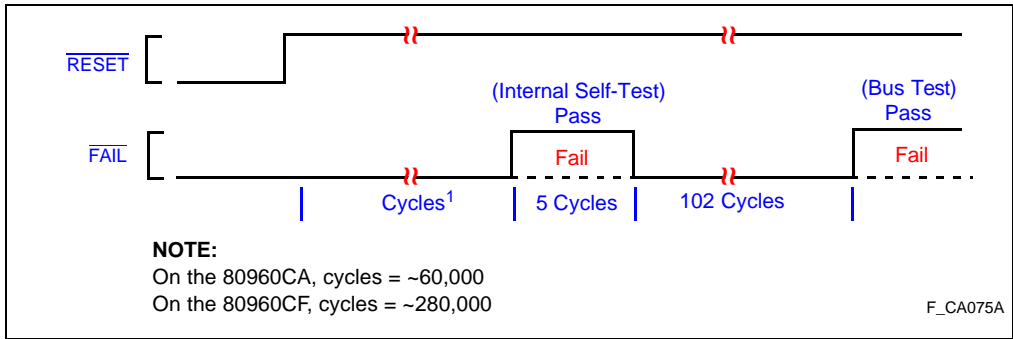
As part of initialization, the i960 Cx processors execute a bus confidence self test and, optionally, an internal self test program. The self test (STEST) pin enables or disables internal self test. The  $\overline{\text{FAIL}}$  pin indicates that either of the self tests passed or failed.

Internal self test checks basic functionality of internal data paths, registers and memory arrays on-chip. Internal self test is not intended for a full validation of the processor’s functionality. Internal self test detects catastrophic internal failures and complements a user’s system diagnostics by ensuring a confidence level in the processor before any system diagnostics are executed.

Internal self test is disabled with the STEST pin. Internal self test can be disabled if the initialization time needs to be minimized or if diagnostics are simply not necessary. The STEST pin is sampled on the rising edge of the  $\overline{\text{RESET}}$  input. If asserted (high), the processor executes the internal self test; if deasserted, the processor bypasses internal self test. The external bus confidence test is always performed regardless of STEST pin value.

The external bus confidence self test checks external bus functionality; it reads eight words from the Initialization Boot Record (IBR) and performs a checksum on the words and the constant FFFF FFFFH. If the processor calculates a sum of zero (0), the test passes. The external bus confidence test can detect catastrophic bus failures such as shorted address, data or control lines in the external system. See section 14.2.4, “Initial Memory Image (IMI)” (pg. 14-5).

The  $\overline{\text{FAIL}}$  pin signals errors in either the internal self test or bus confidence self test.  $\overline{\text{FAIL}}$  is asserted (low) for each self test (Figure 14-1). If the test fails, the pin remains asserted and the processor attempts to stop at the point of failure. If the test passes,  $\overline{\text{FAIL}}$  is deasserted. When the internal self test is disabled (with the STEST pin),  $\overline{\text{FAIL}}$  still toggles at the point where the internal self test would occur even though the internal self test is not executed.  $\overline{\text{FAIL}}$  is deasserted after the bus confidence test passes. In Figure 14-1, all transitions on the  $\overline{\text{FAIL}}$  pin are relative to PCLK2:1 as shown in the 80960CA or CF data sheets.



**Figure 14-1.  $\overline{\text{FAIL}}$  Timing**



### 14.2.3 On-Circuit Emulation

On-circuit emulation aids board level testing. This feature allows a mounted i960 Cx processor to electrically remove itself from a circuit board. In ONCE mode, the processor presents a high impedance on every pin, nearly eliminating the processor's power demands on the circuit board. Once the processor is electrically removed, a functional tester can take the place of (emulate) the mounted processor and execute a test of the i960 Cx processor system.

The on-circuit emulation mode is entered by asserting (low) the  $\overline{\text{ONCE}}$  pin while the i960 Cx processor is in the reset state.  $\overline{\text{ONCE}}$  pin value is latched on  $\overline{\text{RESET}}$  signal's rising edge. The  $\overline{\text{ONCE}}$  pin should be left unconnected in an i960 Cx processor system. The pin is connected to  $V_{CC}$  through an internal pull-up resistor, causing the unconnected pin to remain in the inactive state. To enter on-circuit emulation mode, an external tester simply drives the  $\overline{\text{ONCE}}$  pin low (overcoming the pull-up resistor) and initiates a reset cycle. To exit on-circuit emulation mode, the reset cycle must be repeated with the  $\overline{\text{ONCE}}$  pin deasserted prior to the rising edge of  $\overline{\text{RESET}}$ . (See the i960 CA/CF microprocessor data sheets for specific timing of the  $\overline{\text{ONCE}}$  pin and the characteristics of the on-circuit emulation mode.)

### 14.2.4 Initial Memory Image (IMI)

The IMI comprises the minimum set of data structures that the processor needs to initialize its system. The IMI performs three functions for the processor:

- it provides initial configuration information for the core and integrated peripherals
- it provides pointers to the system data structures and the first instruction to be executed after the processor's initialization
- it provides checksum words that the processor uses in its self test routine at startup

The IMI is made up of three components: the initialization boot record (IBR), process control block (PRCB) and system data structures. Figure 14-2 shows the IMI components. The IBR is fixed in memory; the other components are referenced directly or indirectly by pointers in the IBR and the PRCB.

### 14.2.5 Initialization Boot Record (IBR)

The IBR is the primary data structure required to initialize the i960 Cx processor. The IBR is a 12-word structure which must be located at address FFFF FF00H (see Figure 14-2). The IBR is made up of four components: the initial bus configuration data, the first instruction pointer, the PRCB pointer and the self test checksum data.

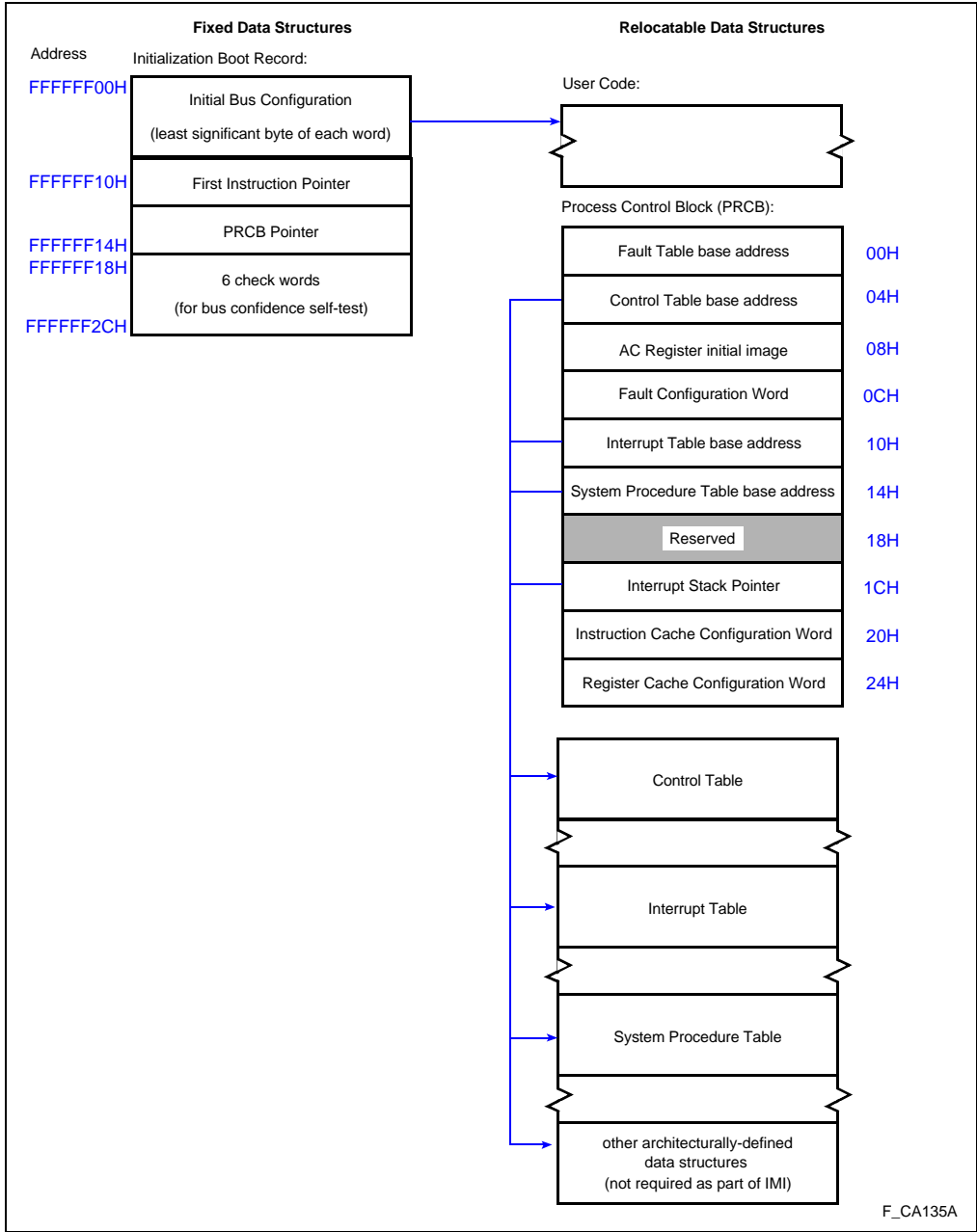


Figure 14-2. Initial Memory Image (IMI) and Process Control Block (PRCB)



When the processor reads the IMI during initialization, it must know the bus characteristics of external memory where the IMI is located. This bus configuration is read from the IBR's first three words. At initialization, the processor performs loads from the lower order byte of the IBR's first three words. These three bytes are combined and loaded into the memory region 0 configuration register (MCON0) to program the initial bus characteristics for the system.

The byte in IBR word 0 is loaded into the lowest byte position of the MCON0 register; the next two bytes from word 1 and word 2 are loaded into successively higher byte positions. The byte in IBR word 4 is reserved and must be set to 00H. This byte is not loaded at initialization. See section 10.2, "MEMORY REGION CONFIGURATION" (pg. 10-2).

When initialization begins, the region configuration table valid bit (BCON.ctv) is cleared. This means that every bus request issued takes configuration information from the MCON0 register, regardless of the memory region associated with the request. The MCON0 register is initially set by microcode to a value which allows the bus configuration data in the IBR to be loaded regardless of actual memory configuration. This is done by configuring the external bus with its most relaxed options:

- Non-burst
- Non-pipelined
- Ready disabled
- Bus width = 8 bits
- Little endian byte order
- $N_{RAD} = 31$
- $N_{RDD} = 3$
- $N_{WAD} = 31$
- $N_{WDD} = 3$
- $N_{XDA} = 3$

With this region configuration, the first byte of bus configuration data is loaded from the IBR. This byte is immediately placed into the lower byte of the MCON0 register. This action provides the user-specified  $N_{RAD}$ , pipeline control, ready control and burst control values for bus configuration. The remaining configuration data bytes are then read with requests which use the new  $N_{RAD}$  value. Once all three bytes are read, MCON0 is rewritten and initialization continues. This reduces the number of clocks required to load the bus configuration data.

The configuration data in MCON0 controls all memory regions. The bus configuration data is typically programmed for a system's region 15 bus characteristics. This is done because the remainder of the IBR and the data structures must be loaded using the new bus characteristics and the IBR is fixed in region 15.

The processor loads the remainder of the IBR which consists of the first instruction pointer, the PRCB pointer and six checksum words. The PRCB pointer and the first instruction pointer are internally cached. The six checksum words — along with the PRCB pointer and the first instruction pointer — are used in a checksum calculation which implements a confidence test of the external bus. The sum of these eight words plus FFFF FFFFH must equal 0.

## INITIALIZATION AND SYSTEM REQUIREMENTS

After the checksum is computed, initialization continues. This includes caching various fields from the PRCB, caching the  $\overline{\text{NMI}}$  vector entry, caching the supervisor stack pointer and computing the frame pointer and stack pointer.

As part of initialization, the processor loads the remainder of the memory region configuration table from the external control table. The Bus Configuration (BCON) register is also loaded at this time. The control table valid (BCON.ctv) bit can be set in the control table to validate the region table after it is loaded. In this way, the bus controller is completely configured during initialization. See section 10.2, “MEMORY REGION CONFIGURATION” (pg. 10-2) for a discussion of memory regions and section 10.3, “PROGRAMMING THE BUS CONTROLLER” (pg. 10-5) for information about configuring the bus controller.

### Example 14-1. Algorithm for Computing the Checksum

```
x ← memory (FFFF FF10H);           read 8 words from physical
                                   address FFFF FF10H
chksum ← FFFFFFFFH add_with_carry x(0);
chksum ← chksum add_with_carry x(1);
chksum ← chksum add_with_carry x(2);
chksum ← chksum add_with_carry x(3);
chksum ← chksum add_with_carry x(4);
chksum ← chksum add_with_carry x(5);
chksum ← chksum add_with_carry x(6);
chksum ← chksum add_with_carry x(7);
```

### 14.2.6 Process Control Block (PRCB)

The PRCB contains base addresses for system data structures and initial configuration information for the core and integrated peripherals (see Figure 14-2). The base address pointers are cached in internal registers at initialization. The base addresses are accessed from these internal registers until the processor is reset or reinitialized.

The initial configuration information is programmed in the arithmetic controls (AC) initial image, the register cache configuration word, the fault configuration word and the instruction cache configuration word. Figure 14-3 shows these configuration words.





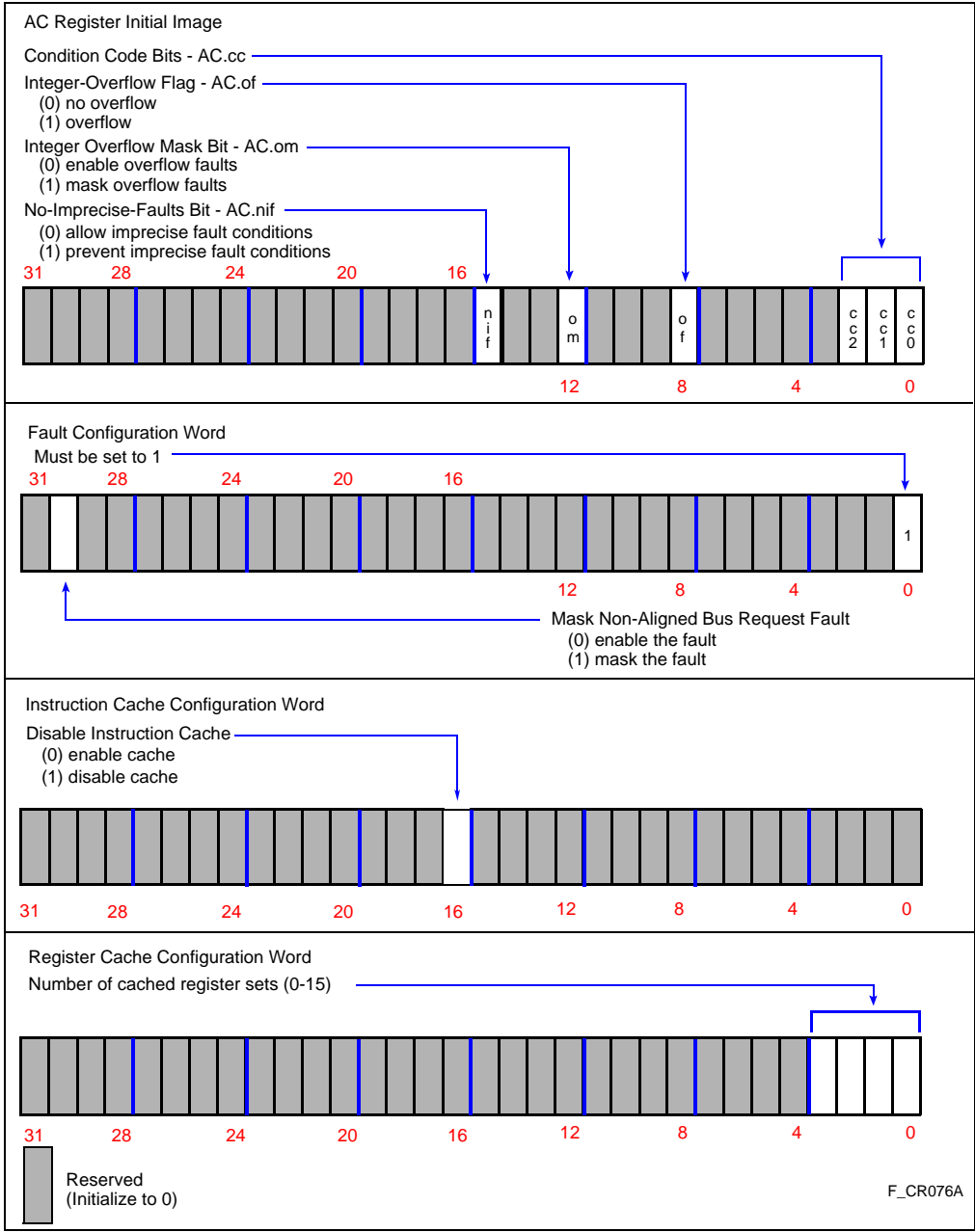


Figure 14-3. Process Control Block Configuration Words

## INITIALIZATION AND SYSTEM REQUIREMENTS

The *AC initial image* is loaded into the on-chip AC register during initialization. The AC initial image allows the initial value of the overflow mask, no imprecise faults bit and condition code bits to be selected at initialization.

The AC initial image condition code bits can be used to specify the source of an initialization or reinitialization when a single instruction entry point to the user startup code is desirable. This is accomplished by programming the condition code in the AC initial image to a different value for each different entry point. The user startup code can detect the condition code values — and thus the source of the reinitialization — by using the compare or compare-and-branch instructions.

The *fault configuration word* allows the operation-unaligned fault to be masked when a non-aligned memory request is issued. (See section 10.4, “DATA ALIGNMENT” (pg. 10-9) for a description of non-aligned memory requests.) If bit 30 in the fault configuration word is set, a fault is not generated when a non-aligned bus request is issued. The i960 Cx processor, in this case, automatically performs the required sequence of aligned bus requests. An application may elect to generate a fault to detect unwanted non-aligned accesses by initializing bit 30 to 0, thus enabling the fault.

The *instruction cache configuration word* allows the instruction cache to be enabled or disabled at initialization. If bit 16 in the instruction cache configuration word is set, the instruction cache is disabled and all instruction fetches are directed to external memory. Disabling the instruction cache is useful for tracing execution in a software debug environment. Instruction cache remains disabled until one of two operations is performed:

- The processor is reinitialized with a new value in the instruction cache configuration word
- **sysctl** is issued with the configure instruction cache message type and a cache configuration mode other than disable cache

The *register cache configuration word* specifies the number of register sets cached on-chip. The integrated procedure call mechanism saves the local register set when a call executes. Local registers are saved to the local register cache. When this cache is full, the oldest set of local registers is flushed to the stack in external memory.

The register cache configuration word's least four bits specify the number of local register sets internally cached. The number programmed in this word specifies from 0 to 15 register sets. When more than five register sets are selected, space is taken from internal data RAM for the register cache. See section 5.2, “CALL AND RETURN MECHANISM” (pg. 5-2) for a complete description of the register caching mechanism.



### 14.3 REQUIRED DATA STRUCTURES

Several data structures are typically included as part of the IMI because values in these data structures are accessed by the processor during initialization. These data structures are usually programmed in the system's boot ROM, located in memory region 15 of the address space. The required data structures are:

- PRCB                      • system procedure table
- IBR                        • control table
- interrupt table

At initialization, the processor loads the supervisor stack pointer from the system procedure table and caches the pointer in an internal register. The supervisor stack pointer is located in the preamble of the system procedure table at byte offset 12 from the base address. System procedure table base address is programmed in the PRCB. See section 5.5.1, "System Procedure Table" (pg. 5-13).

The control table is the data structure that contains the on-chip control register values. It is automatically loaded during initialization and must be completely constructed in the IMI. See section 2.3, "CONTROL REGISTERS" (pg. 2-6) for a description of the control table.

At initialization, the NMI vector is loaded from the interrupt table and saved at location 0000H of the internal data RAM. The interrupt table is typically programmed in the boot ROM and then relocated to RAM by reinitializing the processor. See CHAPTER 6, INTERRUPTS for a description of NMI and the interrupt table.

The remaining data structures which an application may need are the fault table, user stack, supervisor stack and interrupt stack. The necessary stacks must be located in a system's RAM. The fault table is typically located in boot ROM. If it is necessary to locate the fault table in RAM, the processor must be reinitialized.

#### 14.3.1 Reinitializing and Relocating Data Structures

Reinitialization can reconfigure the processor and change pointers to data structures. The processor is reinitialized by issuing the **sysctl** instruction with the reinitialize processor message type. (See section 4.3, "SYSTEM CONTROL FUNCTIONS" (pg. 4-19) for a description of **sysctl**.) The reinitialization instruction pointer and a new PRCB pointer are specified as operands to the **sysctl** instruction. When the processor is reinitialized, the fields in the newly specified PRCB are loaded as described in section 14.2.6, "Process Control Block (PRCB)" (pg. 14-8).

## INITIALIZATION AND SYSTEM REQUIREMENTS

Reinitialization is useful for relocating data structures to RAM after initialization. The interrupt table must be located in RAM: to post software-generated interrupts, the processor writes to the pending priorities and pending interrupts fields in this table. It may also be necessary to relocate the control table to RAM: it must be in RAM if the control register values are to be changed by the user program. In some systems, it is necessary to relocate other data structures (fault table and system procedure table) to RAM because of poor load performance from ROM.

After initialization, the user program is responsible for copying data structures from ROM into RAM. The processor is then reinitialized with a new PRCB which contains the base addresses of the new data structures in RAM.

Reinitialization is required to relocate any of several data structures since the processor caches the pointers to the structures. The processor caches the following pointers during its initialization:

- Interrupt Table Address
- Supervisor Stack Pointer
- Fault Table Address
- PRCB Address
- System Procedure Table Address
- Interrupt Stack Pointer
- Control Table Address

### 14.3.2 Initialization Flow

This section summarizes initialization by presenting a flow of the steps that the processor takes during initialization (Figure 14-4). The entry point for reinitialization is also shown.



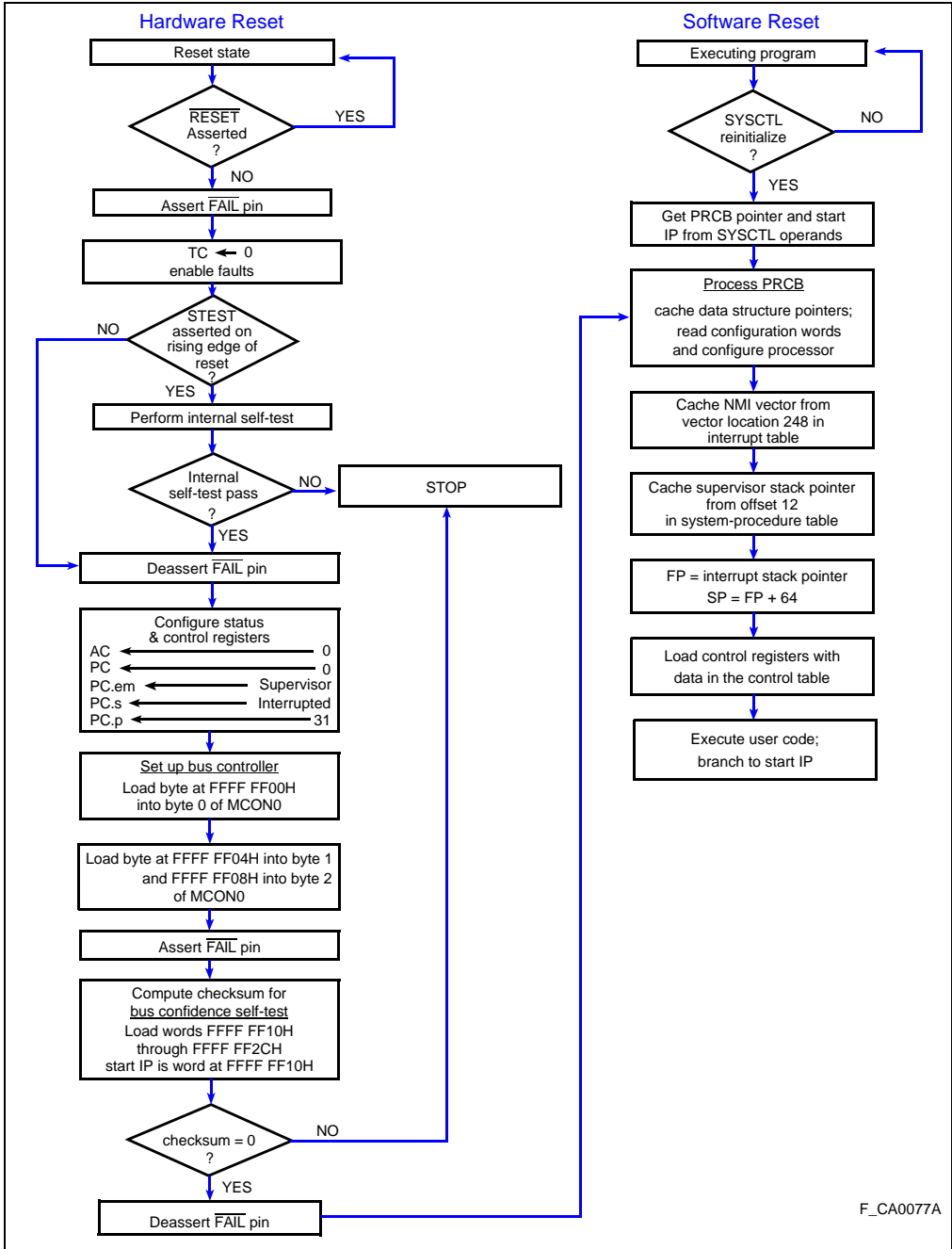


Figure 14-4. Processor Initialization Flow

### 14.3.3 Startup Code Example

After initialization is complete, user startup code typically copies initialized data structures from ROM to RAM, reinitializes the processor, sets up the first stack frame, changes the execution state to non-interrupted and calls the `_main` routine. This section presents an example startup routine and associated header file. This simplified startup file can be used as a basis for more complete initialization routines. The MON960 debug monitor's source code serves as an example of a more complete initialization.

The examples in this section are useful for creating and evaluating startup code. The following lists the example's number, name and page.

- Example 14-2., Startup Routine (`init.s`) (pg. 14-14)
- Example 14-3., High-Level Startup Code (`initmain.c`) (pg. 14-20)
- Example 14-5., Initialization Boot Record File (`rom_ibr.c`) (pg. 14-21)
- Example 14-6., Linker Directive File (`init.ld`) (pg. 14-23)
- Example 14-7., Makefile (pg. 14-24)
- Example 14-8., Initialization Header File (`init.h`) (pg. 14-25)

#### Example 14-2. Startup Routine (`init.s`) (Sheet 1 of 6)

```

/*-----*/
/*  init.s                                */
/*-----*/

/* initial PRCB */

    .globl  _rom_prcb
    .align 4
_rom_prcb:
    .word  boot_flt_table           # 0 - Fault Table
    .word  _boot_control_table     # 4 - Control Table
    .word  0x00001000              # 8 - AC reg mask overflow fault
    .word  0x40000001              # 12 - Flt CFG- Allow Unaligned
    .word  boot_intr_table         # 16 - Interrupt Table
    .word  rom_sys_proc_table      # 20 - System Procedure Table
    .word  0                       # 24 - Reserved
    .word  _intr_stack             # 28 - Interrupt Stack Pointer
    .word  0x00000000              # 32 - Inst. Cache - enable cache
    .word  5                       # 36 - Reg. Cache - 5 sets cached

```

## Example 14-2. Startup Routine (init.s) (Sheet 2 of 6)

```
/* ROM system procedure table */

.equ    supervisor_proc, 2
.text
.align 6
rom_sys_proc_table:
.space 12                # Reserved
.word  _supervisor_stack # Supervisor stack pointer
.space 32                # Preserved
.word  _default_sysproc  # sysproc 0
.word  _default_sysproc  # sysproc 1
.word  _default_sysproc  # sysproc 2
.word  _default_sysproc  # sysproc 3
.word  _default_sysproc  # sysproc 4
.word  _default_sysproc  # sysproc 5
.word  _default_sysproc  # sysproc 6
.word  _fault_handler + supervisor_proc # sysproc 7
.word  _default_sysproc  # sysproc 8
.space 251*4            # sysproc 9-259

/* Fault Table */

.equ    syscall, 2
.equ    fault_proc, 7
.text
.align 4
```

## Example 14-2. Startup Routine (init.s) (Sheet 3 of 6)

```

boot_flt_table:
.word   (fault_proc<<2) + syscall   # 0-Parallel Fault
.word   0x27f
.word   (fault_proc<<2) + syscall   # 1-Trace Fault
.word   0x27f
.word   (fault_proc<<2) + syscall   # 2-Operation Fault
.word   0x27f
.word   (fault_proc<<2) + syscall   # 3-Arithmetic Fault
.word   0x27f
.word   (fault_proc<<2) + syscall   # 4-Reserved
.word   0x27f
.word   (fault_proc<<2) + syscall   # 5-Constraint Fault
.word   0x27f
.word   (fault_proc<<2) + syscall   # 6-Reserved
.word   0x27f
.word   (fault_proc<<2) + syscall   # 7-Protection Fault
.word   0x27f
.word   (fault_proc<<2) + syscall   # 8-Reserved
.word   0x27f
.word   (fault_proc<<2) + syscall   # 9-Reserved
.word   0x27f
.word   (fault_proc<<2) + syscall   # 0xa-Type Fault
.word   0x27f
.space  21*8                        # reserved

/* Boot Interrupt Table */

.text
boot_intr_table:
.word   0
.word   0, 0, 0, 0, 0, 0, 0, 0, 0
.word   _intx, _intx, _intx, _intx, _intx, _intx, _intx, _intx, _intx, _intx
.word   _intx, _intx, _intx, _intx, _intx, _intx, _intx, _intx, _intx, _intx
.word   _intx, _intx, _intx, _intx, _intx, _intx, _intx, _intx, _intx, _intx
.word   _intx, _intx, _intx, _intx, _intx, _intx, _intx, _intx, _intx, _intx
.word   _intx, _intx, _intx, _intx, _intx, _intx, _intx, _intx, _intx, _intx
.word   _intx, _intx, _intx, _intx, _intx, _intx, _intx, _intx, _intx, _intx
.word   _intx, _intx, _intx, _intx, _intx, _intx, _intx, _intx, _intx, _intx
.word   _intx, _intx, _intx, _intx, _intx, _intx, _intx, _intx, _intx, _intx

```





## Example 14-2. Startup Routine (init.s) (Sheet 4 of 6)

```
.word  _intx, _intx, _intx, _intx, _intx, _intx, _intx, _intx
.word  _intx, _intx, _intx, _intx, _intx, _intx, _intx, _intx
.word  _intx, _intx, _intx, _intx, _intx, _intx, _intx, _intx
.word  _intx, _intx, _intx, _intx, _intx, _intx, _intx, _intx
.word  _intx, _intx, _intx, _intx, _intx, _intx, _intx, _intx
.word  _intx, _intx, _intx, _intx, _intx, _intx, _intx, _intx
.word  _intx, _intx, _intx, _intx, _intx, _intx, _intx, _intx
.word  _intx, _intx, _intx, _intx, _intx, _intx, _intx, _intx
.word  _intx, _intx, _intx, _intx, _intx, _intx, _intx, _intx
.word  _intx, _intx, _intx, _intx, _intx, _intx, _intx, _intx
.word  _intx, _intx, _intx, _intx, _intx, _intx, _intx, _intx
.word  _intx, _intx, _intx, _intx, _intx, _intx, _intx, _intx
.word  _intx, _intx, _intx, _intx, _intx, _intx, _intx, _intx
.word  _intx, _intx, _intx, _intx, _intx, _intx, _intx, _intx
.word  _intx, _intx, _intx, _intx, _intx, _intx, _intx, _intx
.word  _intx, _intx, _intx, _intx, _intx, _intx, _intx, _intx
.word  _intx, _intx, _intx, _intx, _intx, _intx, _intx, _intx
.word  _intx, _intx, _intx, _intx, _intx, _intx, _intx, _intx
.word  _intx, _intx, _intx, _intx, _intx, _intx, _intx, _intx
.word  _intx, _intx, _intx, _intx, _intx, _intx, _intx, _intx

/* START */
/* Processor starts execution here after reset. */
.text
.globl _start_ip
.globl _reinit
_start_ip:
    mov    0, g14                /* g14 must be 0 for ic960 C compiler */
/* Copy the .data area into RAM. It has been packed in the ROM
 * after the code area. If the copy is not needed (RAM-based monitor),
 * the symbol rom_data can be defined as 0 in the linker directives file.
 */
    lda    rom_data, g1          # load source of copy
    cmpobe 0, g1, 1f
    lda    __Bdata, g2           # load destination
    lda    __Edata, g3
init_data:
    ldq    (g1), r4
    addo   16, g1, g1
    stq    r4, (g2)
    addo   16, g2, g2
    cmpobl g2, g3, init_data
1:
```

## Example 14-2. Startup Routine (init.s) (Sheet 5 of 6)

```

/* Initialize the BSS area of RAM. */
lda    __Bbss, g2          # start of bss
lda    __Ebss, g3          # end of bss
movq   0, r4
bss_fill:
stq    r4, (g2)
addo   16, g2, g2
cmpobl g2, g3, bss_fill
/* Save initial value of g0; it contains the stepping number. */
st     g0, _componentid
_reinit:
ldconst 0x300, r4          # reinitialize sys control
lda     1f, r5
lda     _rom_prcb, r6
sysctl  r4, r5, r6
1:
mov     0, g14

lda     _user_stack, g0    /* new fp */
lda     _user_stack, g1    /* new pfp */
call    move_frame

ldconst 0x001f2403, r3     /* PC mask */
ldconst 0x000f0003, r4     /* PC value */
modpc   r3, r3, r4        /* out of interrupted state */

call    _main              # to main routine

terminated:
fmark   # cause breakpoint trace fault
b       terminated
/* move_frame -
   g0 - new frame pointer (FP)
   g1 - new previous frame pointer (PFP)
This routine switches stacks. It should be called using a "local"
call. The new stack pointer (SP) is calculated by finding the
relative offset between the old FP and old SP, then adding this
offset to the new FP.
*/

```

## Example 14-2. Startup Routine (init.s) (Sheet 6 of 6)

```
move_frame:
    andnot 0xf, pfp, r3    /* old FP */
    mov    g0, r6         /* new FP */
    flushreg
    ld     4(r3), r4      /* old SP */
    subo  r3, r4, r5     /* old SP offset from FP */
1:
    ldq   (r3), r8       /* from old frame */
    addo  16, r3, r3
    stq   r8, (r6)       /* to new frame */
    addo  16, r6, r6
    cmpobl r3, r4, 1b

    addo  g0, r5, r4     /* new SP */
    st    g1, (g0)      /* store new PFP in new frame */
    st    r4, 4(g0)     /* store new SP in new frame */
    mov   g0, pfp       /* new FP */
    ret

    .globl _intr_stack
    .globl _user_stack
    .globl _supervisor_stack
    .bss   _user_stack, 0x0200, 6      # default application stack
    .bss   _intr_stack, 0x0200, 6     # interrupt stack
    .bss   _supervisor_stack, 0x0600, 6 # fault (supervisor) stack

    .text
_fault_handler:
    ldconst 'F', g0
    call   _co
    ret

_default_sysproc:
    ret

_intx:
    ldconst 'I', g0
    call   _co
    ret
```

**Example 14-3. High-Level Startup Code (initmain.c)**

```

unsigned componentid = 0;

main()
{
    /* system- or board-specific code goes here */
}
/* this code is called by init.s */
co()
{
    /* system or board-specific output routine goes here */
}

```

**Example 14-4. Control Table (ctltbl.c) (Sheet 1 of 2)**

```

/*-----*/
/*  ctbltbl.c                                     */
/*-----*/
#include "init.h"

typedef struct
{
    unsigned control_reg[28];
}CONTROL_TABLE;

const CONTROL_TABLE boot_control_table = {
    /* -- Group 0 -- Breakpoint Registers */
    0, 0, 0, 0,
    /* -- Group 1 -- Interrupt Map Registers */
    0, 0, 0, /* Interrupt Map Regs (set by code as needed) */
    0xc3bc, /* ICON
            *       - dedicated mode,
            *       - enabled
            * sdm 0 - falling edge activated,
            * sdm 1 - falling edge activated,
            * sdm 2 - falling edge activated,
            * sdm 3 - falling edge activated,
            * sdm 4 - level-low activated,
            * sdm 5 - falling edge activated,
            * sdm 6 - falling edge activated,
            * sdm 7 - falling edge activated,
            *       - mask unchanged,
            *       - not cached,
            *       - fast,
            *       - DMA suspended
            */
};

```

**Example 14-4. Control Table (ctltbl.c) (Sheet 2 of 2)**

```

/* -- Groups 2-5 -- Bus Configuration Registers */

DEFAULT,      /* Region 0 */
DEFAULT,      /* Region 1 */
DEFAULT,      /* Region 2 */
DEFAULT,      /* Region 3 */
DEFAULT,      /* Region 4 */
DEFAULT,      /* Region 5 */
DEFAULT,      /* Region 6 */
DEFAULT,      /* Region 7 */
DEFAULT,      /* Region 8 */
DEFAULT,      /* Region 9 */
DEFAULT,      /* Region 10 */
DEFAULT,      /* Region 11 */
DEFAULT,      /* Region 12 */
I_O,          /* Region 13 */
DRAM,         /* Region 14 */
FLASH,        /* Region 15 */

/* -- Group 6 -- Breakpoint, Trace and Bus Control Registers */
0,            /* Reserved */
0,            /* BPCON Register (reserved by monitor) */
0,            /* Trace Controls */
1            /* BCON Register (Region config. valid) */
};

```

**Example 14-5. Initialization Boot Record File (rom\_ibr.c) (Sheet 1 of 2)**

```

#include "init.h"
/*
 * NOTE: The ibr must be located at 0xFFFFF00. Use the linker to
 * locate this structure.
 * The boot configuration is almost always region F, since the IBR
 * must be located there
 */
#define BOOT_CONFIGFLASH

extern void start_ip();
extern unsigned rom_prcb;
extern unsigned checksum;

#define CS_6 (int) &checksum /* value calculated in linker */

```

**Example 14-5. Initialization Boot Record File (rom\_ibr.c) (Sheet 2 of 2)**

```

const IBR init_boot_record =
{
  BYTE_N(0,BOOT_CONFIG),
  0,0,0,
  BYTE_N(1,BOOT_CONFIG),
  0,0,0,
  BYTE_N(2,BOOT_CONFIG),
  0,0,0,
  BYTE_N(3,BOOT_CONFIG),
  0,0,0,
  start_ip,
  &rom_prcb,
  -2,
  0,
  0,
  0,
  0,
  CS_6
};

```

**Example 14-6. Linker Directive File (init.ld) (Sheet 1 of 2)**

```

/*-----*/
/*  init.ld                                */
/*-----*/

MEMORY
{
  /*
   Enough space must be reserved in ROM after the text
   section to hold the initial values of the data section.
  */
  rom:      o=0xffff0000,l=0xfc00
  rom_dat:  o=0xfffffc00,l=0x0300    /* placeholder for .data image */

  ibr:      o=0xfffff00,l=0x00ff
  data:     o=0xe0000000,l=0x1000
}

```



## Example 14-6. Linker Directive File (init.ld) (Sheet 2 of 2)

```

SECTIONS
{
  .ibr :
  {
    rom_ibr.o
  } > ibr
  .text :
  {
    *(.text)
    . = ALIGN(0x10);
  } > rom
  .data :
  {
  } > data
  .bss :
  {
  } > data
}

rom_data = __Etext;          /* used in init.s as source of .data
                             section initial values. ROM960
                             "move" command places the .data
                             section right after the .text section */

_checksum = -(_rom_prcb + _start_ip);

/*
**move $0 .text 0
**move $0
**move $0 .ibr 0xFF00
**map $0
**mkimage $0 $0.ima
**quit
*/

```

14

## Example 14-7. Makefile (Sheet 1 of 2)

```

/*-----*/
/*  makefile                               */
/*-----*/

```

## Example 14-7. Makefile (Sheet 2 of 2)

```
LDFILE = init
FINALOBJ = init
OBJS = init.o ctltbl.o initmain.o
IBR = rom_ibr.o
LDLFLAGS = -ACA -Fcoff -T$(LDFILE) -m
ASFLAGS = -ACA -V
CCFLAGS = -ACA -Fcoff -V -c
init.ima: $(FINALOBJ)
    rom960 $(LDFILE) $(FINALOBJ)

init: $(OBJS) $(IBR)
    gld960 $(LDLFLAGS) -o $< $(OBJS)

.s.o:
    gas960c $(ASFLAGS) $<

.c.o:
    gcc960 $(CCFLAGS) $<
```





## Example 14-8. Initialization Header File (init.h) (Sheet 1 of 2)

```

/*-----*/
/*  init.h                                     */
/*-----*/

#define BYTE_N(n,data)  (((unsigned)(data) >> (n*8)) & 0xFF)
typedef struct
{
    unsigned charbus_byte_0;
    unsigned charreserved_0[3];
    unsigned charbus_byte_1;
    unsigned charreserved_1[3];
    unsigned charbus_byte_2;
    unsigned charreserved_2[3];
    unsigned charbus_byte_3;
    unsigned charreserved_3[3];
    void          (*first_inst)();
    unsigned      *prcb_ptr;
    int           check_sum[6];
}IBR;

#define BURST(on)      ((on)?0x1:0)
#define READY(on)     ((on)?0x2:0)
#define PIPELINE(on)  ((on)?0x4:0)
#define BIG_ENDIAN(on) ((on)?(0x1<<22):0)

/* Bus Width can be 8,16 or 32, default to 8 */
#define BUS_WIDTH(bw)  ((bw==16)?(1<<19):(0)) | ((bw==32)?(2<<19):(0))

/* Wait States */
#define NRAD(ws)      ((ws>-1 && ws<32)?(ws<<3 ):0) /* ws can be 0-31 */
#define NRDD(ws)     ((ws>-1 && ws<4 )?(ws<<8 ):0) /* ws can be 0-3 */
#define NXDA(ws)     ((ws>-1 && ws<4 )?(ws<<10):0) /* ws can be 0-3 */
#define NWAD(ws)     ((ws>-1 && ws<32)?(ws<<12):0) /* ws can be 0-31 */
#define NWDD(ws)     ((ws>-1 && ws<4 )?(ws<<17):0) /* ws can be 0-3 */

/* Bus configuration */
#define DEFAULT      (BUS_WIDTH(8) | READY(0) | BURST(0) | BIG_ENDIAN(0) | \
                    PIPELINE(0) | NRAD(8) | NRDD(0) | NXDA(1) | \
                    NWAD(8) | NWDD(0))

#define I_O          (BUS_WIDTH(8) | READY(0) | BURST(0) | BIG_ENDIAN(0) | \
                    PIPELINE(0) | NRAD(13) | NRDD(0) | NXDA(3) | \
                    NWAD(13) | NWDD(0))

```

**Example 14-8. Initialization Header File (init.h) (Sheet 2 of 2)**

```
#define DRAM      (BUS_WIDTH(32) | READY(1) | BURST(1) | BIG_ENDIAN(0) | \
                 PIPELINE(0) | NRAD(2) | NRDD(1) | NXDA(1) | \
                 NWAD(2) | NWDD(1))

#define FLASH    (BUS_WIDTH(8) | READY(0) | BURST(0) | BIG_ENDIAN(0) | \
                 PIPELINE(0) | NRAD(4) | NRDD(0) | NXDA(1) | \
                 NWAD(4) | NWDD(0))
```

**14.4 SYSTEM REQUIREMENTS**

The following sections discuss generic hardware requirements for a system built around the i960 Cx processor. This section describes electrical characteristics of the i960 Cx processor’s interface to the external circuit. The CLKIN, RESET, STEST, FAIL, ONCE, V<sub>SS</sub> and V<sub>CC</sub> pins are described in detail. Specific signal functions for the external bus signals, DMA signals and interrupt inputs are discussed in their respective sections in this manual.

**14.4.1 Input Clock (CLKIN)**

The clock input (CLKIN) determines processor execution rate and timing. The clock input is internally divided by two — or used directly — to produce the external processor clock outputs, PCLK1 and PCLK2. The CLKMODE pin state determines whether the input clock is in two-X or one-X mode. When CLKMODE is tied to ground or left floating, the CLKIN input is internally divided by two to produce PCLK2:1 (2X mode). When CLKMODE is pulled to a logic 1 (high), the CLKIN input is used to create PCLK2:1 at the same frequency, using an internal phase-locked loop circuit (1X mode). Refer to the i960 CA/CF microprocessor data sheets for CLKIN specifications.

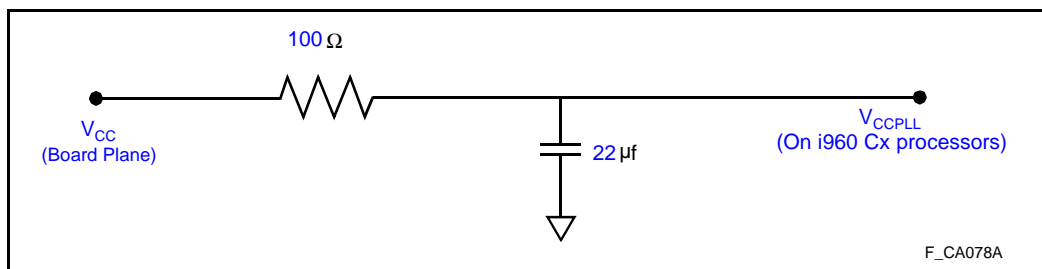
The clock input is designed to be driven by most common TTL crystal clock oscillators. The clock input must be free of noise and conform with the specifications listed in the data sheet. CLKIN input capacitance is minimal; for this reason, it may be necessary to terminate the CLKIN circuit board trace at the processor to prevent overshoot and undershoot. Additionally, a series-damping resistor may be required to damp ringing on the input.



**14.4.2 Power and Ground Requirements ( $V_{CC}$ ,  $V_{SS}$ )**

The large number of  $V_{SS}$  and  $V_{CC}$  pins effectively reduces the impedance of power and ground connections to the chip and reduces transient noise induced by current surges. The i960 Cx processor is implemented in CHMOS IV technology. Unlike NMOS processes, power dissipation in the CHMOS process is due to capacitive charging and discharging on-chip and in the processor’s output buffers; there is almost no DC power component. The nature of this power consumption results in current surges when capacitors charge and discharge. The processor’s power consumption depends mostly on frequency. It also depends on voltage and capacitive bus load (see the i960 CA/CF microprocessor data sheets).

To reduce clock skew on later versions of the i960 Cx processor, the  $V_{CC}$  pin for the Phase Lock Loop (PLL) circuit is isolated on the pinout. The lowpass filter, as shown in Figure 14-5, reduces CLKIN to PCLK2:1 skew in system designs. This circuit is compatible with those i960 Cx processor versions which do not implement isolated PLL power.



**Figure 14-5.  $V_{CCPLL}$  Lowpass Filter**

**14.4.3 Power and Ground Planes**

Power and ground planes must be used in i960 Cx processor systems to minimize noise. Justification for these power and ground planes is the same as for multiple  $V_{SS}$  and  $V_{CC}$  pins. Power and ground lines have inherent inductance and capacitance; therefore, an impedance  $Z=(L/C)^{1/2}$ . Total characteristic impedance for the power supply can be reduced by adding more lines. This effect is illustrated in Figure 14-6, which shows that two lines in parallel have half the impedance of one. To reduce impedance even further, add more lines. Ideally, a plane — an infinite number of parallel lines — results in the lowest impedance. Fabricate ground planes with a minimum of 2 oz. copper.

All power and ground pins must be connected to a plane. Ideally, the i960 Cx processor should be located at the center of the board to take full advantage of these planes, simplify layout and reduce noise.

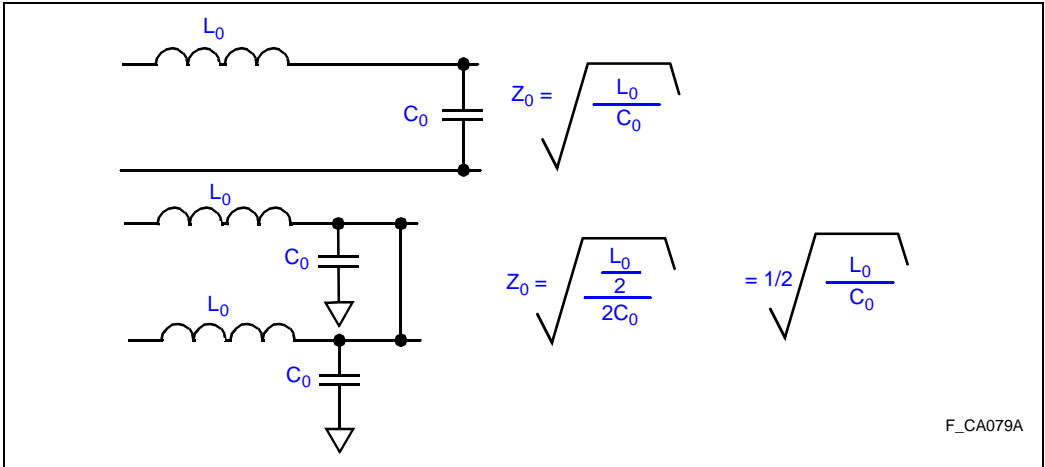


Figure 14-6. Reducing Characteristic Impedance

**14.4.4 Decoupling Capacitors**

Decoupling capacitors placed across the device between  $V_{CC}$  and  $V_{SS}$  reduce voltage spikes by supplying the extra current needed during switching. Place these capacitors close to their devices because connection line inductance negates their effect. Also, for this reason, the capacitors should be low inductance. Chip capacitors (surface mount) exhibit lower inductance and require less board space than conventional leaded capacitors.

**14.4.5 I/O Pin Characteristics**

The i960 Cx processor interfaces to its system through its pins. This section describes the general characteristics of the input and output pins.

**14.4.5.1 Output Pins**

All output pins on the i960 Cx processor are three-state outputs. Each output can drive a logic 1 (low impedance to  $V_{CC}$ ); a logic 0 (low impedance to  $V_{SS}$ ); or float (present a high impedance to  $V_{CC}$  and  $V_{SS}$ ). Each pin can drive an appreciable external load. The i960 CA/CF microprocessor data sheets describe each pin’s drive capability and provide timing and derating information to calculate output delays based on pin loading.

Output drivers on the i960 Cx processor are specially designed to provide a uniform drive current over the entire range of operating temperatures and voltages. This feature eliminates excess noise produced by output drivers under adverse operating conditions.



14.4.5.2 Input Pins

All i960 Cx processor inputs are designed to detect TTL thresholds, providing compatibility with the vast amount of available random logic and peripheral devices that use TTL outputs.

Most i960 Cx processor inputs are synchronous inputs (Table 14-3). A synchronous input pin must have a valid level (TTL logic 0 or 1) when the value is used by internal logic. If the value is not valid, it is possible for a metastable condition to be produced internally. The metastable condition is avoided by qualifying the synchronous inputs with the rising edge of PCLK2:1 or a derivative of PCLK2:1. The i960 CA/CF microprocessor data sheets specify input valid setup and hold times relative to PCLK for the synchronized inputs.

Table 14-3. i960 Cx Processor Input Pins

| Synchronous Inputs              | Asynchronous Inputs<br>(sampled by PCLK2:1)  | Asynchronous Inputs<br>(sampled by RESET) |
|---------------------------------|--|---|
| D31:0<br>READY<br>BTERM<br>HOLD | RESET<br>XINT7:0<br>NMI<br>DREQ3:0<br>EOP3:0 | STEST<br>ONCE<br>CLKMODE                  |

i960 Cx processor inputs which are considered asynchronous are internally synchronized to the rising edge of PCLK2:1. Since they are internally synchronized, the pins only need to be held long enough for proper internal detection. In some cases, it is useful to know if an asynchronous input will be recognized on a particular PCLK2:1 cycle or held off until a following cycle. The i960 CA/CF microprocessor data sheets provide setup and hold requirements relative to PCLK2:1 which ensure recognition of an asynchronous input on a particular clock. The data sheets also supply hold times required for detection of asynchronous inputs.

The ONCE, CLKMODE and STEST inputs are asynchronous inputs. These signals are sampled and latched on the rising edge of the RESET input instead of PCLK2:1.

14.4.6 High Frequency Design Considerations

At high signal frequencies and/or with fast edge rates, the transmission line properties of signal paths in a circuit must be considered. Reflections, interference and noise become significant in comparison to the high-frequency signals. These errors can be transient and therefore difficult to debug. In this section, some high-frequency design issues are discussed; for more information, consult a reference book on high-frequency design.



### 14.4.7 Line Termination

Input voltage level violations are usually due to voltage spikes that raise input voltage levels above the maximum limit (overshoot) and below the minimum limit (undershoot). These voltage levels can cause excess current on input gates, resulting in permanent damage to the device. Even if no damage occurs, many devices are not guaranteed to function as specified if input voltage levels are exceeded.

Signal lines are terminated to minimize signal reflections and prevent overshoot and undershoot. Terminate the line if the round-trip signal path delay is greater than signal rise or fall time. If the line is not terminated, the signal reaches its high or low level before reflections have time to dissipate and overshoot or undershoot occurs.

For the i960 Cx processor, two termination methods are attractive: AC and series. An AC termination damps the signal at the end of the series line; termination compensates for excess current before the signal travels down the line.

Series termination decreases current flow in the signal path by adding a series resistor as shown in Figure 14-7. The resistor increases signal rise and fall times so that the change in current occurs over a longer period of time. Because the amount of voltage overshoot and undershoot depends on the change in current over time ( $V = L di/dt$ ), the increased time reduces overshoot and undershoot. Place the series resistor as close as possible to the signal source. Series termination, however, reduces signal rise and fall times, so it should not be used when these times are critical.

AC termination is effective in reducing signal reflection (ringing). This termination is accomplished by adding an RC combination at the signal's destination (Figure 14-8). While the termination provides no DC load, the RC combination damps signal transients.

Selection of termination methods and values is dependent upon many variables, such as output buffer impedance, board trace impedance and length and timings that must be met.

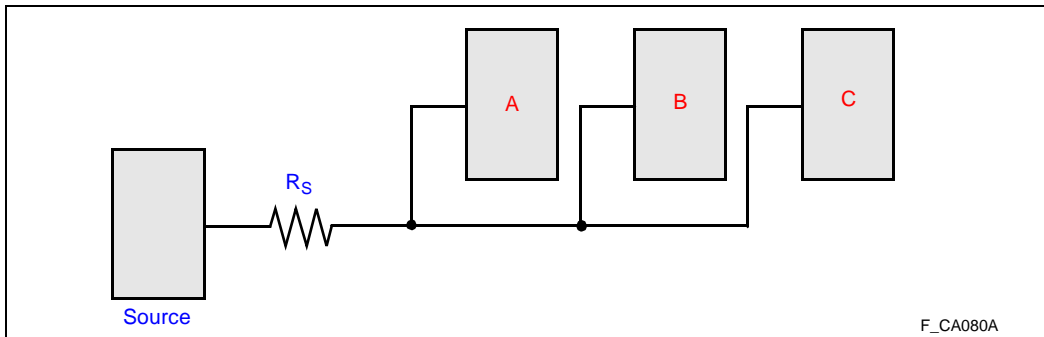


Figure 14-7. Series Termination

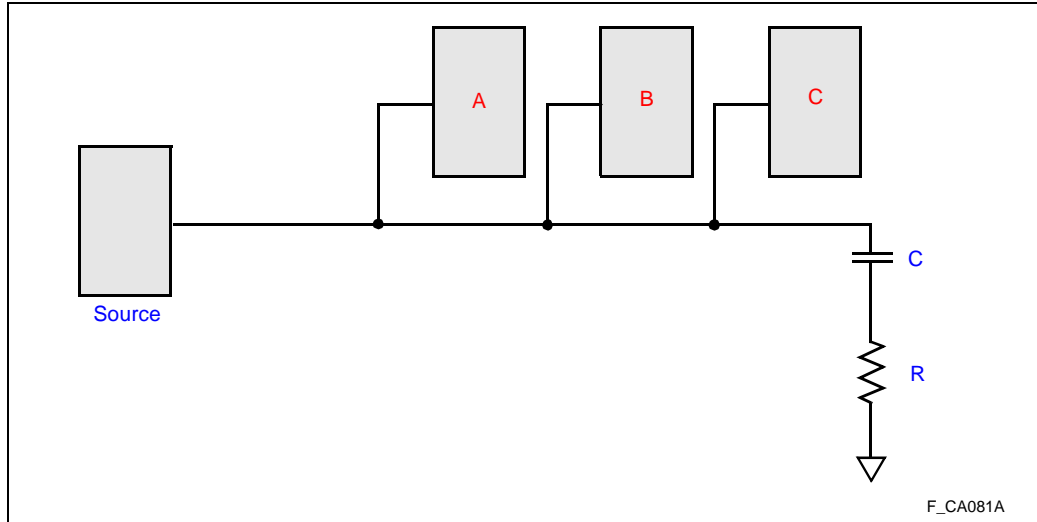


Figure 14-8. AC Termination

#### 14.4.8 Latchup

Latchup is a condition in a CMOS circuit in which  $V_{CC}$  becomes shorted to  $V_{SS}$ . Intel's CHMOS IV process is immune to latchup under normal operation conditions. Latchup can be triggered when the voltage limits on I/O pins are exceeded, causing internal PN junctions to become forward biased. The following guidelines help prevent latchup:

- Observe the maximum rating for input voltage on I/O pins.
- Never apply power to an i960 Cx processor pin or a device connected to an i960 Cx processor pin before applying power to the i960 Cx processor itself.
- Prevent overshoot and undershoot on I/O pins by adding line termination and by designing to reduce noise and reflection on signal lines.

#### 14.4.9 Interference

Interference is the result of electrical activity in one conductor that causes transient voltages to appear in another conductor. Interference increases with the following factors:

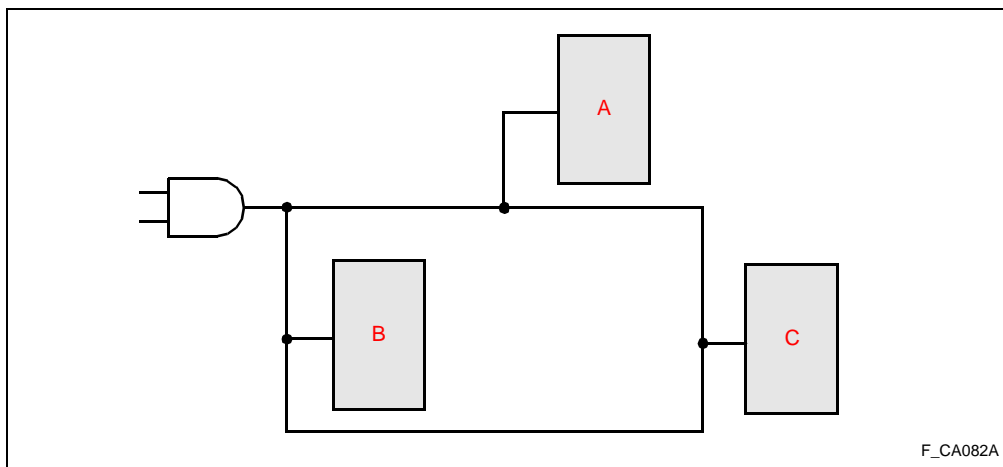
- Frequency Interference is the result of changing currents and voltages. The more frequent the changes, the greater the interference.
- Closeness-of-two-conductors Interference is due to electromagnetic and electrostatic fields whose effects are weaker further from the source.

## INITIALIZATION AND SYSTEM REQUIREMENTS

Two types of interference must be considered in high frequency circuits: electromagnetic interference (EMI) and electrostatic interference (ESI).

EMI (also called crosstalk) is caused by the magnetic field that exists around any current-carrying conductor. The magnetic flux from one conductor can induce current in another conductor, resulting in transient voltage. Several precautions can minimize EMI:

- Run ground lines between two adjacent lines wherever they traverse a long section of the circuit board. The ground line should be grounded at both ends.
- Run ground lines between the lines of an address bus or a data bus if either of the following conditions exist:
  - The bus is on an external layer of the board.
  - The bus is on an internal layer but not sandwiched between power and ground planes that are at most 10 mils away.
- Avoid closed loops in signal paths (Figure 14-9). Closed loops cause excessive current and create inductive noise, especially in the circuitry enclosed by a loop.



**Figure 14-9. Avoid Closed-Loop Signal Paths**

ESI is caused by the capacitive coupling of two adjacent conductors. The conductors act as the plates of a capacitor; a charge built up on one induces the opposite charge on the other.

The following steps reduce ESI:

- Separate signal lines so that capacitive coupling becomes negligible.
- Run a ground line between two lines to cancel the electrostatic fields.







A

INSTRUCTION EXECUTION  
AND PERFORMANCE  
OPTIMIZATION

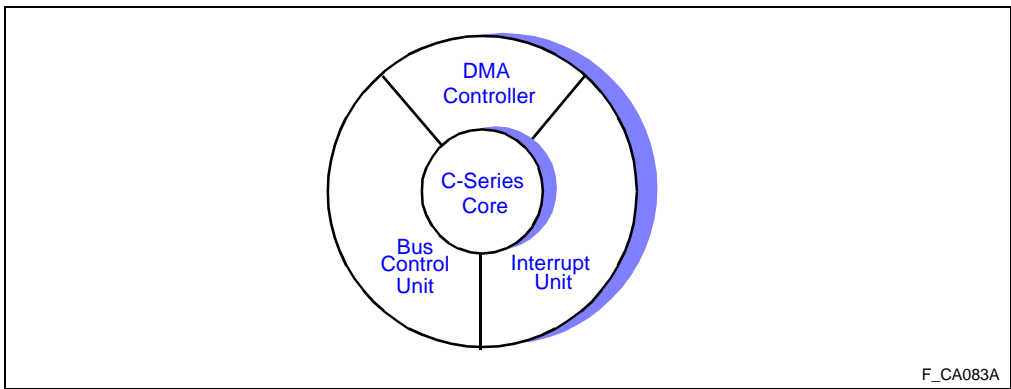
I



# APPENDIX A INSTRUCTION EXECUTION AND PERFORMANCE OPTIMIZATION

This appendix describes the i960<sup>®</sup> Cx processors' core architecture and core features which enhance the processors' performance and parallelism. This appendix also describes assembly language techniques for achieving the highest instruction-stream performance.

The i960 core architecture defines the programming environment, basic interrupt mechanism and fault mechanism for all members of the i960 microprocessor family. The C-series core is a high-performance, highly parallel implementation. The i960 Cx processors integrate a bus controller, DMA controller and interrupt controller around the core architecture (Figure A-1).



**Figure A-1. C-Series Core and Peripherals**

State-of-the-art silicon technology and innovative microarchitectural constructs achieve high performance due to these features:

- Parallel instruction decoding allows sustained, simultaneous execution of two instructions in every clock cycle.
- Most instructions execute in a single clock cycle.
- Multiple, independent execution units enable multi-clock instructions to execute in parallel.
- Resource and register scoreboarding provide efficient and transparent management for parallel execution.
- Branch look-ahead and branch prediction features enable branches to execute in parallel with other instructions.



- A local register cache permits fast calls, returns, interrupts and faults to be implemented.
- A 1 Kbyte (80960CA) or 4 Kbyte (80960CF) two-way set associative instruction cache is integrated on-chip.
- A 1 Kbyte direct-mapped data cache is integrated on-chip (80960CF only).
- 1 Kbyte of static data RAM is integrated on-chip.

## A.1 INTERNAL PROCESSOR STRUCTURE

The i960 Cx processor core contains the following main functional units:

- Instruction Scheduler (IS)
- Register File (RF)
- Execution Unit (EU)
- Multiply/Divide Unit (MDU)
- Address Generation Unit (AGU)
- Data RAM/Local Register Cache

Figure A-2 shows the i960 Cx processor block diagram. The IS and RF are the “heart” of the processor. Other core functional units — referred to as *coprocessors* — interface to the IS and RF, connecting to either the register (REG) side or the memory (MEM) side of the processors.

The IS issues directives via the REG and MEM interfaces which target a specific coprocessor. That coprocessor then executes an express function virtually decoupled from the IS and the other coprocessors. The REG and MEM data buses transfer data between the common RF and the coprocessors.

The i960 Cx processors are designed to allow application specific coprocessors to interface to the IS in the same way as core-defined coprocessors. The integrated peripherals — bus controller, interrupt controller and DMA controller — interface to the i960 Cx processors’ REG and MEM sides.



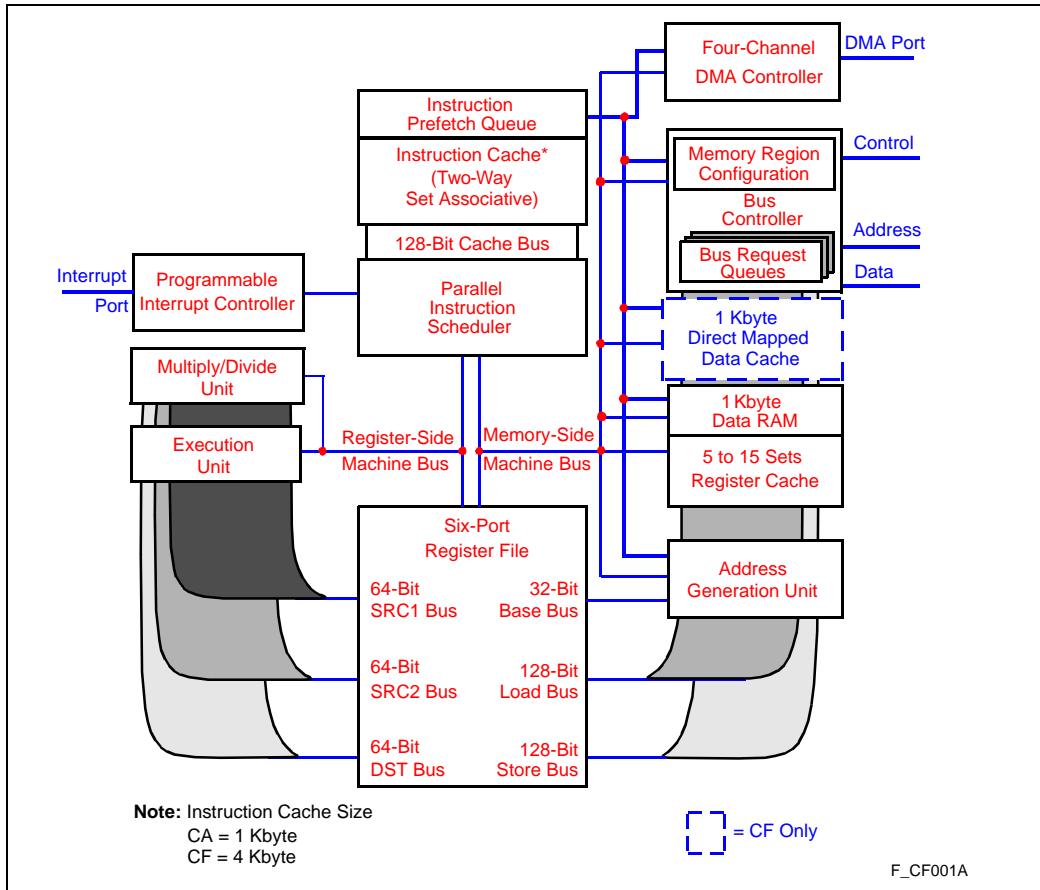


Figure A-2. i960<sup>®</sup> CA/CF Microprocessor Block Diagram

### A.1.1 Instruction Scheduler (IS)

The IS decodes the instruction stream and drives the decoded instructions onto the machine bus, which is the major control bus. The IS can decode up to three instructions at a time, one from each of three different classes of instructions: one REG format, one MEM format and one CTRL format instruction. The IS directly executes the CTRL format instruction (branches), manages the instruction pipeline and keeps track of which instructions are in the pipeline so faults can be detected.



The IS is assisted by three associated functional blocks: instruction fetch unit, instruction cache and microcode ROM.



The instruction fetch unit provides the IS with up to four words of instructions each cycle. It extracts instructions from the instruction cache, microcode ROM and its instruction fetch queue for presentation to the scheduler. The instruction fetch unit requests external fetch operations from the bus controller whenever a cache miss occurs.

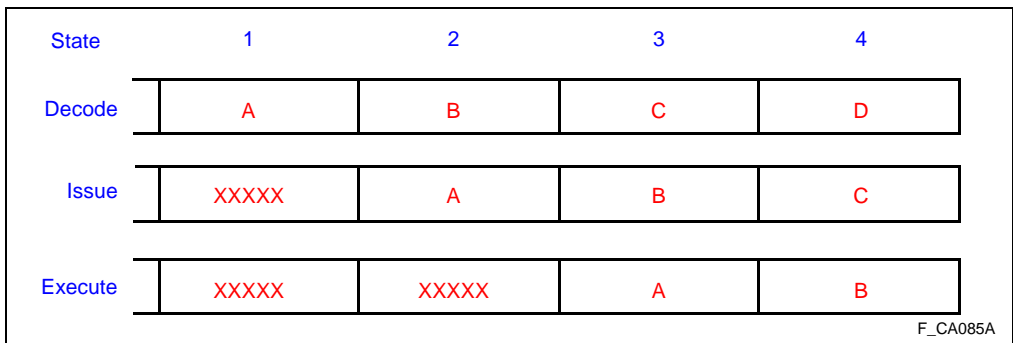
The instruction cache is 1 Kbyte (80960CA) or 4 Kbyte (80960CF), two-way set associative. This cache delivers to the IS up to four instructions per clock. The cache allows many inner loops of code to execute with no external instruction fetches; this maximizes the core’s performance.

The i960 Cx processors use a microcode engine to implement complex instructions and functions. This includes implicit and explicit calls, returns, DMA assists and initialization sequences. Microcode provides a method for implementing complex instructions in the processors’ RISC environment. Unlike conventional microcode, i960 Cx processor microcode uses a RISC subset of the instruction set in addition to specific micro-instructions. Microcode, therefore, can be thought of as a RISC program containing operational routines for complex instructions. When the instruction pointer references a microcoded instruction, the instruction fetch unit automatically branches to the appropriate microcode routine. The i960 Cx processors perform this microcode branch in 0 clocks.

**A.1.2 Instruction Flow**

Most instructions flow through a three-stage pipeline (Figure A-3):

- The decode stage calculates the address used to fetch the next instruction from the instruction cache. Additionally, this stage starts decoding the instruction.
- The issue stage completes instruction decode and sends it to the appropriate execution unit.
- During the execute stage, the operation is performed and the result is returned to the RF.



**Figure A-3. Instruction Pipeline**



In the decode stage, the IS decodes the instruction and calculates the next instruction address. This could be a macro- or micro-instruction address. It is either the next sequential address or the target of a branch. For conditional branches, the IS uses condition codes or internal hardware flags to determine which way to branch. If branch conditions are not valid when the IS sees a branch, the processor guesses the branch direction, using the branch prediction specified in the instruction. If the guess was wrong, the IS cancels the instructions on the wrong path and begins fetching along the correct path.

In the issue stage, instructions are emitted or issued to the rest of the machine via the machine bus. The machine bus consists of three parts: REG format instruction portion, MEM format instruction portion and CTRL format portion. Each part of the machine bus goes to the coprocessor that executes the appropriate instruction. The RF supplies operands and stores results for REG and MEM format instructions. For this reason, the RF is connected to both the REG and MEM portions of the machine bus. The CTRL portion stays within the instruction sequencer since it directly executes the branch operations. Several events occur when an instruction is issued:

1. The information is driven onto the machine bus.
2. The IS reads the source operands and checks that all resources needed to execute the instruction are available.
3. The instruction is cancelled if any resource that the instruction requires is busy. The resource is busy if a previous, incomplete instruction reserved it or the resource is already working on an instruction.
4. The IS then attempts to re-issue the instruction on the next clock; the same sequence of events is repeated.

This processor resource management mechanism is called *resource scoreboarding*. A specific form of resource scoreboarding is register scoreboarding. When an instruction's computation stage takes more than one clock, the result registers are scoreboarded. A subsequent operation needing that particular register is delayed until the multi-clock operation completes. Instructions which do not use the scoreboarded registers can execute in parallel.

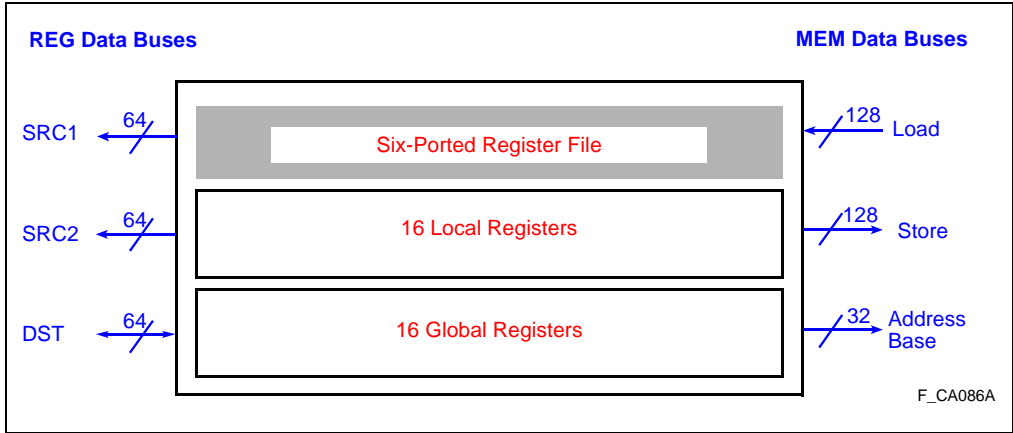
The execute stage performs the instruction. This stage is handled by the coprocessors which connect to the REG- and MEM-side buses. In this stage, the coprocessor has received operands from the RF and recognized opcode which tells the coprocessor which instruction to execute. Execution begins and a result is returned in this stage for single clock instructions.

The execute stage is a single- or multi-clock pipeline stage, depending on the operation performed and the coprocessor targeted. For single-clock coprocessors—such as the integer execution unit—the result of an operation is always returned immediately. Because of the three-stage pipeline construction and the register bypassing mechanism, no conflicts between source access and result return can occur. For multi-clock coprocessors—such as the multiply/divide unit—the coprocessor must arbitrate access to the return path.

**A**

**A.1.3 Register File (RF)**

The RF contains the 16 local and 16 global registers and has six ports (Figure A-4). This allows several of the core’s coprocessors to access the register set in parallel. This parallel access results in an ability to execute one simple logic or arithmetic instruction, one memory operation (**LOAD/STORE**) and one address calculation per clock.



**Figure A-4. Six-Port Register File**

MEM coprocessors interface to the RF with a 128-bit wide load bus and a 128-bit wide store bus. An additional 32-bit port allows the Address Generation Unit to simultaneously fetch an address or address reduction operand. These wide load and store data paths:

- enable up to four words of source data and four words of destination data to simultaneously pass between the RF and a MEM coprocessor in a single clock.
- provide a high-bandwidth path between data RAM, data cache (80960CF only) and local register cache to implement high-speed data operations.
- provide a highly efficient means for moving load, store and fetch data between the bus controller and the RF.

REG coprocessors interface to the RF with two 64-bit source buses and a single 64-bit destination bus. The source and result from different REG coprocessors can access the RF simultaneously using this bus structure. The 64-bit source and destination buses allow the **eshro**, **mov** and **movl** instructions to execute in a single cycle.





To manage register dependencies during parallel register accesses, *register bypassing* (result forwarding) is implemented. The register bypassing mechanism is activated whenever an instruction's source register is the same as the previous instruction's destination register. The instruction pipeline allows no time for the contents of a destination register to be written before it is read again by another instruction. Because of this, the RF forwards the result data from the return bus directly to the source bus without reading the source register.

#### A.1.4 Execution Unit (EU)

The EU is the i960 Cx processor core's 32-bit arithmetic and logic unit. The EU can be viewed as a self-contained REG coprocessor with its own instruction set. As such, the EU is responsible for executing or supporting the execution of all integer and ordinal arithmetic instructions, logic and shift instructions, move instructions, bit and bit-field instructions and compare operations. The EU performs any arithmetic or logical instructions in a single clock.

#### A.1.5 Multiply/Divide Unit (MDU)

The MDU is a REG coprocessor which performs integer and ordinal multiply, divide, remainder and modulo operations. The MDU detects integer overflow and divide by zero errors. The MDU is optimized for multiplication, performing extended multiplies (32 by 32) in four to five clocks. The MDU performs multiplies and divides in parallel with the main execution unit.

#### A.1.6 Address Generation Unit (AGU)

The AGU is a MEM coprocessor which computes the effective addresses for memory operations. It directly executes the load address instruction (**lda**) and calculates addresses for loads and stores based on the addressing mode specified in these instructions. Address calculations are performed in parallel with the main execution unit (EU).

#### A.1.7 Data RAM and Local Register Cache

The data RAM and local register cache are part of a 1.5 Kbyte block of on-chip Static RAM (SRAM). One Kbyte of this SRAM is mapped into the i960 Cx processors' address space from location 00000000H to 000003FFH. A portion of the remaining 512 bytes is dedicated to the local register cache. This part of internal SRAM is not directly visible to the user. Loads and stores—including quad-word accesses—to the internal data RAM are typically performed in only one clock. The complete local register set, therefore, can be moved to the local register cache in only four clocks.

**A**

**A.1.8 Data Cache (80960CF Only)**

The i960 CF processor has a 1 Kbyte direct-mapped data cache which enhances performance by reducing the number of load and store accesses to external memory. The data cache can return up to a quad word (128 bits) to the register file in a single clock cycle on a cache hit.

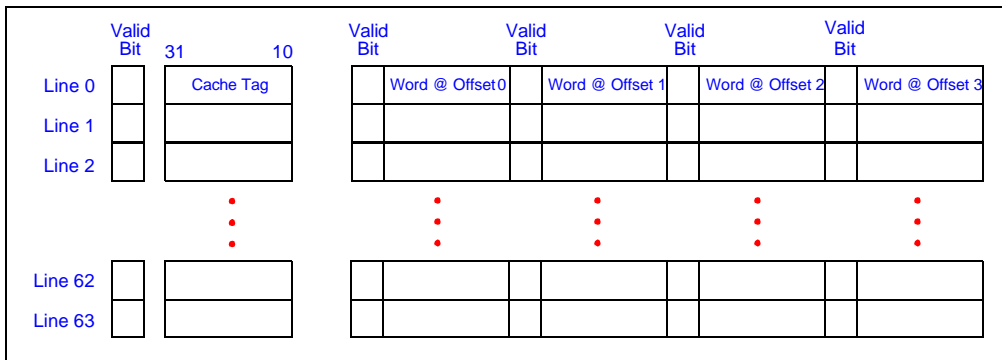
External memory is configured as cacheable or non-cacheable on a region-by-region basis, using special bits in the memory region configuration registers MCON0-15. This makes it easy to partition a system into cacheable regions (local memory) and non-cacheable regions.

The i960 CF processor implements a simple coherency mechanism. The data cache can also be enabled, disabled or invalidated on a global basis through programming.

**A.1.8.1 Data Cache Organization**

The data cache has a four-word line size (see Figure A-5). Each of the 64 cache lines has an associated cache tag containing the 22 most significant bits of the address and a valid bit. Each line is further subdivided into single-word blocks, each with its own valid bit. This *subblock placement* technique reduces latency on cache misses.

Data accesses result in cache hits and misses. Accesses that match valid address tags and word(s) marked as valid are cache hits; other data accesses are misses.



**Figure A-5. Data Cache Organization**



### A.1.8.2 Bus Configuration

Certain data accesses are implicitly non-cacheable. All DMA and atomic (**atmod**, **atadd**) accesses are non-cacheable. User settings in the memory region configuration registers MCON0-15 determine which data accesses are cacheable or non-cacheable. Registers MCON0-15 divide memory into 16 blocks whose characteristics are programmed through **sysctl** instructions. Refer to section 4.3, “SYSTEM CONTROL FUNCTIONS” (pg. 4-19).

Micro-flow execution breaks unaligned accesses into aligned accesses; cacheability is determined as described in the preceding paragraph. Data objects that cross programming boundaries may be only partially in the data cache, resulting in a combination of cache hits and misses.

Upon reset or initialization, the processor clears all valid bits to zero to ensure that accesses are not made to a cache line that may contain invalid data.

### A.1.8.3 Global Control of the Cache

The data cache is globally enabled or disabled by a bit in the DMA Command Register. The following example code shows how to disable the cache. Setting the data cache disable bit does not take effect until the second clock after the **setbit** instruction is executed. Any load/store issued in parallel with **setbit** or on the following clock will be directed to the data cache. Disabling the cache does not invalidate any of its entries.

```

setbit  30,sf2,sf2  # set the bit to dynamically disable
                        # data cache
mov     g0,g0      # wait two clocks before executing
mov     g0,g0      # any code which accesses the data cache

```

The DMA Control Register’s data cache invalidate bit can be set to quickly invalidate the entire cache. This invalidation clears all the individual valid bits in the data cache array. The effect of changing this bit is also delayed by two clocks. If multiple cacheable loads are pending in the BCU queues when the cache is invalidated, the processor continuously invalidates the cache until the loads are finished. Once all cacheable loads are complete and all valid bits have been cleared, the data cache invalidate bit reverts to 0.

Upon reset or initialization, the data cache is globally disabled and invalidated to ensure that accesses are not made to a cache line that may contain invalid data.

A

#### A.1.8.4 Data Fetch Policy

Data fetch policy determines what happens for a load that misses the cache. The i960 CF processor employs a *natural* fetch policy. Word, double-word, triple-word and quad-word loads are issued to the bus control logic in their original widths. Byte and short-word loads are promoted to word bus requests. Because most applications have 32-bit data buses, there is seldom a bandwidth penalty for promoting a byte or short word load to a full word bus operation.

#### A.1.8.5 Write Policy

Write policy determines what happens on cacheable store operations. The write policy for the i960 CF processor is *write-through* and *write-allocate*. For cacheable stores, data is written into both the cache and external memory simultaneously, regardless of whether the write is a hit or miss. This maintains coherency between the data cache and external memory.

For cacheable stores that are equal to or greater than a word in length, cache tags and appropriate valid bits are updated whenever data is written into the cache. Consider a word store as an example. The tag is always updated and its valid bit is set. The appropriate valid bit for that word is always set and the other three valid bits are always cleared.

Cacheable stores that are less than a word in length are handled differently. Byte and short-word stores that hit the cache (i.e., are contained in valid words within valid cache lines) do not change the tag and valid bits. The processor writes the data into the cache and external memory as usual. A byte or short-word store to an invalid word within a valid cache line leaves the word valid bit cleared because the rest of the word is still invalid. In all cases the processor simultaneously writes the data into the cache and the external memory.

#### A.1.8.6 Data Cache Coherency

DMA cycles and atomic accesses from the **atmod** and **atadd** instructions are implicitly non-cacheable. Otherwise, entire memory regions would have to be programmed as non-cacheable to support routine DMA and semaphore operations.

Whenever the cacheability of a region is changed, cache coherency becomes an immediate issue. The coherency mechanism solves this issue directly. The processor compares a non-cacheable store to the relevant tag in the data cache. If the store address matches the tag, the processor invalidates the entire cache line. In a single processor system, this guarantees that the data cache never contains stale data. When the data cache is globally disabled, all stores are non-cacheable and the processor invalidates relevant tags whenever addresses match.



**A.1.8.7 BCU Pipeline and Data Cache Interaction**

The BCU’s interaction with the data cache affects overall bus throughput. Figure A-6 shows how the BCU and data cache process a series of hits and misses for cacheable loads and stores.

```
ld (g0),g1 :data cache hit
ld (g2),g4 :data cache miss
ld (g3),g8 :data cache hit
st g1,(g0) :store is scoreboardd
```

|                              |                      |         |         |     |              |            |          |    |    |
|------------------------------|----------------------|---------|---------|-----|--------------|------------|----------|----|----|
| <b>Instruction Scheduler</b> | ld                   | ld      | --      | ldq | --           | --         | st       |    |    |
| <b>BCU Pipeline</b>          | Address Out Bus      |         | g2      |     |              |            | g0       |    |    |
|                              | St Bus               |         |         |     |              |            | g1       |    |    |
|                              | External Address Bus |         |         | g2  |              |            |          | g0 |    |
|                              | External Data Bus    |         |         |     | (g2)         |            |          |    | g1 |
|                              | LD Bus               |         |         |     |              | g4←(g2)    |          |    |    |
| <b>Data Cache Pipeline</b>   | Address Out Bus      | g0 Hit  | g2 Miss |     | g3 Hit       |            | g0       |    |    |
|                              | St Bus               |         |         |     |              |            | Cache←g1 |    |    |
|                              | LD Bus               | g1←(g0) |         |     | quad g8←(g3) | Cache←(g2) |          |    |    |

**Figure A-6. BCU and Data Cache Interaction**

During the first issue clock, the data cache receives the first load address and recognizes a cache hit. The following clock is an execute clock; the cache returns data to the register file over the LD bus. In the next issue clock the cache receives the second load address and recognizes a miss. It is passed on to the BCU in the following clock. The BCU then processes the load as if there were no data cache. Note that the following load quad instruction is scoreboardd for a single clock while the previous cache miss is issued to the BCU. The load quad instruction is determined to be a hit in the third issue clock and its full 128 bits of data is returned to the register file in the following execute clock.

The i960 CF microprocessor scoreboardd the store instruction until the pending load returns data to the cache. The processor writes the data to the register file and the cache in the same clock, updating the cache tag and valid bits. In the next clock, the store instruction is issued. For the store, the processor writes unconditionally into the cache during the issue clock.



When using the i960 CF processor, refer to Table A-13 and Table A-10 for a listing of the single clock load and store instructions. The table is valid when offset, displacement or indirect addressing modes are used over an external bus with the following characteristics:

$$N_{XAD} = N_{XDD} = N_{XDA} = 0, \text{ Burst On, Pipelining On, Ready Disabled}$$





For other addressing modes, information in section A.2.6, “Micro-flow Execution” (pg. A-36) still applies.

For each instruction that requires multiple reads on the external bus, such as **ldq**, the BCU buffers the return data until all data is returned from the bus. This optimization reduces the internal load bus overhead to a minimum and allows the processor to access the MEM-side while external loads are in progress. If instructions are issued back-to-back with no register dependencies and hit the cache, execution can proceed at the rate of one instruction per clock. For cache misses, the processor issues instructions until the cache is full. Subsequent back-to-back execution proceeds at bus bandwidth.

**Table A-1. BCU Instructions for the i960 CF Processor**

| Mnemonic  | Issue Clocks | Result Latency Clocks | Back-to-Back Throughput | Result Latency Clocks | Back-to-Back Throughput |
|---|--------------|-----------------------|-------------------------|-----------------------|-------------------------|
|   |              | Hits                  | Hits                    | Misses                | Misses                  |
| <b>ld</b><br><b>ldob</b><br><b>ldib</b><br><b>ldos</b><br><b>ldis</b> | 1            | 1                     | 1                       | 4                     | 2                       |
| <b>ldl</b>  | 1            | 1                     | 1                       | 5                     | 3                       |
| <b>ldt</b>  | 1            | 1                     | 1                       | 6                     | 4                       |
| <b>ldq</b>  | 1            | 1                     | 1                       | 7                     | 5                       |
| <b>st</b><br><b>stob</b><br><b>stib</b><br><b>stos</b><br><b>stis</b> | 1            | N/A                   | 2                       | N/A                   | 2                       |
| <b>stl</b>  | 1            | N/A                   | 3                       | N/A                   | 3                       |
| <b>stt</b>  |              | N/A                   | 4                       | N/A                   | 4                       |
| <b>stq</b>  |              | N/A                   | 5                       | N/A                   | 5                       |

**A.1.8.8 BCU Queues and Cache Coherency**

The bus control unit is implemented as a coprocessor. Many clock cycles can pass after a cacheable load instruction is issued before data is returned to the data cache and registers. Because of this delay, the BCU was modified to support data cache operation. The processor scoreboards all stores when cacheable loads are present in the BCU queue. Consider the following case:

```
ld    xyz, R0 # load from address xyz misses the data cache
st    r4,xyz  # store is issued to the same address
```



The load instruction misses the data cache and is then issued to the bus control unit. It can take several clocks before data is actually written to r0 and the data cache. If the store were issued before the load returns data, an inconsistency would result. External memory would receive correct data from the store, but the data cache would contain incorrect data from the load. The processor prevents this inconsistency by stalling the store until the load returns data.

Since typical programs are not rich in store instructions, the policy of scoreboarding stores on outstanding cacheable loads decreases overall processor performance less than one percent.

#### A.1.8.9 DMA Operation and Data Coherency

The policy of scoreboarding stores on cacheable loads does not apply to stores that the DMA controller generates. A DMA store is issued to the BCU regardless of any cacheable loads in the bus request queues.

DMA processes and user processes share core resources. The core alternates CPU cycles between the DMA processes and the user processes. If a DMA store waited for all cacheable loads to complete, large numbers of sequential cacheable loads from a user process could lock out the DMA store indefinitely. This condition would be compounded by the fact that two of the three BCU queues are assigned to the user process when DMA is active.

Allowing DMA stores to be unconditionally issued makes the DMA process more deterministic, but it poses one potential data cache coherency issue. When the user process has a cacheable load pending in the BCU and the DMA issues a store to the same address, stale data can end up in the cache. It is up to the user to synchronize such operations in software. There are three possible solutions:

- Wait for the entire DMA transfer to complete before reading the data.
- Check the DMA destination address to ensure that the DMA has progressed beyond the address in question before reading it.
- Disable the data cache for the memory region while the DMA operation is underway.

#### A.1.8.10 External I/O and Bus Masters and Cache Coherency

The i960 CF processor implements a single processor coherency mechanism. There is no hardware mechanism—such as bus snooping—to support multiprocessing. If another bus master can change shared memory, there is no guarantee that the data cache contains the most recent data. The user must manage such data coherency issues in software.

Users typically program the MCON0-15 registers such that I/O regions are non-cacheable. Partitioning the system this way eliminates I/O as a source of coherency problems.

## A.2 PARALLEL INSTRUCTION PROCESSING

At the center of the i960 Cx processor core is a set of parallel processing units capable of executing multiple single-clock instructions in every clock. To support this rate, the IS can issue up to three new instructions in every clock. Each processing unit has access to the multiple ports of the chip's six-ported register file; therefore, each processing unit can execute instructions independently and in parallel.

In general, the register file, instruction scheduler, cache and fetch unit keep the parallel processing units busy, given the typical diversity of instructions found in a rolling quad-word group of instructions. To achieve highly optimized performance for critical code sequences, the user must understand how instructions execute on the processor.

The following section describes instruction execution on the i960 Cx processors with the goal of instruction stream optimization in mind. See section A.2.7, "Coding Optimizations" (pg. A-43) for specific optimization techniques applicable to the i960 Cx processors.

### A.2.1 Parallel Issue

The IS looks at a rolling quad-word group of unexecuted instructions every clock and issues all instructions which can be executed in that clock. The scheduler can issue up to three instructions every clock to the processing units and can sustain an issue rate of two instructions per clock. To achieve parallelism, the IS detects to which machine "side" — REG, MEM or CTRL — each instruction in the current quad-word group belongs.

When the IS issues a group of instructions, the appropriate parallel processing units acknowledge receipt and begin execution. However, register and resource dependencies can delay instruction execution. The processor transparently manages these interactions through register scoreboarding and register bypassing.

To maximize the IS's ability to issue instructions in parallel, the instruction cache is organized to provide three or four instructions per clock to the scheduler. To minimize the cost of a cache miss, the instruction fetch unit constantly checks whether a cache miss will occur on the next clock. If a miss is imminent, an instruction fetch is issued.

The following discussions assume that instructions are always available from the instruction cache. For a discussion of cache organization and the impact of cache misses, see section A.2.5, "Instruction Cache And Fetch Execution" (pg. A-33).





### A.2.2 Parallel Execution

Six parallel processing units are attached to the six-ported register file:

|            |   |
|------------|---|
| MEM-side:  | Three units are attached to the machine's memory side. MEM-side instructions are dispatched over the MEM machine-bus.   |
| BCU        | Bus Control Unit executes memory reads and writes for instructions which reference an operand in external memory.   |
| DR         | Data RAM handles memory reads and writes for instructions which reference on-chip data RAM.   |
| AGU        | Address Generation Unit executes the <b>lda</b> , <b>callx</b> , <b>bx</b> and <b>balx</b> instructions and assists address calculation for all loads and stores. |
| REG-side:  | Two units are attached to the register side. REG-side instructions are dispatched over the REG machine bus.   |
| MDU        | Multiply/Divide Unit executes the multiply, divide, remainder, modulo and extended multiply and divide instructions.  |
| EU         | Execution Unit executes all other arithmetic, logical, shift, comparison, bit, bit field, move instructions and the <b>scanbyte</b> instruction.                  |
| CTRL-side: | One unit is on the control side.  |
| IS         | Instruction Scheduler directly executes control instructions by modifying the next instruction pointer given to the instruction cache.                            |

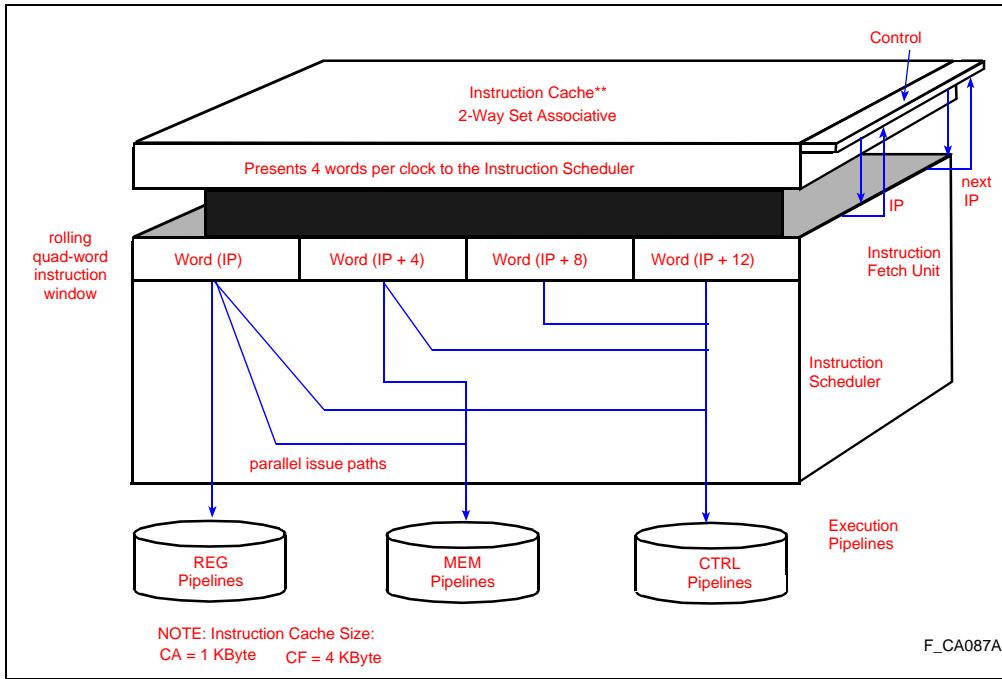
The processor uses on-chip ROM to execute instructions not directly executed by one of the parallel processing units. This ROM contains a sequence of RISC instructions for each complex instruction not directly executable in one of the parallel processing units. When the scheduler encounters a complex instruction, the appropriate sequence of RISC instructions is issued for execution. This sequence of instructions is called a *micro-flow*.

The IS can issue multiple instructions in every clock when the instructions decoded in that clock can be executed by different machine sides. For example, an add can begin in the same clock as a load since the addition is performed by the EU on the REG side, while the load is executed by the BCU on the MEM side. Furthermore, a branch can be issued in the same clock as the add and load since the IS executes it directly (three instructions per clock). The IS does not exploit every possible combination of three instruction types in four consecutive words. Table A-2 summarizes the sequences of instruction machine types that can be issued in parallel. A group of one or more instructions which can be issued in the same clock is referred to in this appendix as an *executable group* of instructions. Figure A-7 shows the paths that the IS has available for dispatching each word of the rolling quad-word to the three machine sides.

A

**Table A-2. Machine Type Sequences Which Can Be Issued In Parallel**

| Sequence | Description  |
|----------|--|
| R M x x  | REG-side followed immediately by a MEM-side instruction  |
| R M C x  | REG-side followed immediately by a MEM-side followed immediately by a CTRL instruction                   |
| R M x C  | REG-side followed immediately by a MEM-side followed by a CTRL instruction in the same rolling quad-word |
| R C x x  | REG-side followed immediately by a CTRL instruction  |
| R x C x  | REG-side followed by a CTRL instruction in the same rolling quad-word                                    |
| R x x C  |  |
| M C x x  | MEM-side followed immediately by a CTRL instruction  |
| M x C x  | MEM-side followed by a CTRL instruction in the same rolling quad-word                                    |
| M x x C  |  |



**Figure A-7. Issue Paths**

### A.2.3 Scoreboarding

When the scheduler issues a group of instructions, the targeted parallel processing units immediately acknowledge receipt of instructions and the scheduler begins considering the next four unexecuted words of the instruction stream. The scheduler checks for register dependencies between instructions *before* issuing them. The scheduler does not issue a group of instructions if:

1. a register is specified as a destination more than once, or
2. a register is specified as a destination in one instruction and a source in a subsequent instruction

A single register may, however, be specified as a source in multiple instructions or as a source in one instruction and a destination in a subsequent instruction. The six-port register set supports these cases. For example, the following instructions *cannot* be issued in parallel due to register dependencies:

```
addo    g0, g1, g2    # g2 is a destination
st      g2, (g3)     # g2 is a source;
                               # store must wait for addo to complete
```

or:

```
addo    g0, g1, g2    # g2 is a destination
ld      (g3), g2     # g2 is also a destination;
                               # load must wait for addo to complete
```

However, the following instructions *can* be issued in parallel:

```
addo    g0, g1, g2    # g0 is a source for both instructions
st      g0, (g3)
```

or:

```
addo    g0, g1, g2    # g0 is a source for addo and
ld      (g3), g0     # a destination for load
```

In all cases of parallel instruction issue, the IS ensures that the program operates as if the instructions were actually issued sequentially.

**A**

Two conditions can delay the execution of one or more of the instructions that the scheduler attempted to issue: a *scoreboarded register* or a *scoreboarded resource*.

### A.2.3.1 Register Scoreboarding

If an instruction's source (or destination) register is the destination of a prior incomplete multi-clock instruction (such as a load), the instruction is delayed. The scheduler attempts to reissue the instruction every clock until the scoreboarded register is updated and the delayed instruction can be executed. Table 1-3 summarizes conditions which cause a delay due to a scoreboarded register.

**Table 1-3. Scoreboarded Register Conditions**

| Condition       | Description  |
|-----------------|--|
| <i>src</i> busy | One or both of the registers specified as a source for the instruction was referenced as a destination of a prior instruction which has not completed. |
| <i>dst</i> busy | The destination referenced by the instruction was referenced as a destination of a prior instruction which has not completed.                          |
| <i>cc</i> busy  | AC register condition codes are not valid. Correct branch prediction eliminates dead clocks due to condition code dependencies.                        |

### A.2.3.2 Resource Scoreboarding

A scoreboarded resource also defeats the scheduler's attempt to issue an instruction. A resource is scoreboarded when it is needed to execute the instruction but is not available. The parallel processing units are the resources. Table A-4 lists cases which cause an instruction to be delayed due to a scoreboarded resource. Text that follows the table describes what happens to an instruction once it is issued to a processing unit.

### A.2.3.3 Prevention of Pipeline Stalls

To maintain the logical intent of the sequential instruction stream, the i960 Cx processors implement register scoreboarding and register bypassing. Examples of each are demonstrated in the descriptions and examples in this appendix. These mechanisms eliminate possible pipeline stalls due to parallel register access dependencies. It is not necessary to perform any code optimizations to take advantage of this parallel support hardware.

Register scoreboarding maintains register coherency by preventing parallel execution units from accessing registers for which there is an outstanding operation. When the IS issues an instruction which requires multiple clocks to return a result, the instruction's destination register is locked to further accesses until it is updated. To manage this destination register locking, the processors use a 33rd bit in each register to indicate whether the register is available or locked. This bit is called the scoreboard bit. There is a scoreboard bit for each of the 32 registers.



**Table A-4. Scoreboarded Resource Conditions**

| Condition      | Description  |
|----------------|--|
| BCU Queue Full | Bus Controller queues are full and the scheduler is attempting to issue a memory request.  |
| MDU Busy       | The Multiply/Divide Unit is busy executing a previously issued instruction and the scheduler is attempting to issue another instruction for which the MDU is responsible.  |
| DR Busy        | <p>On-chip data RAM can support one 128-bit load or store every clock. However, the data RAM has no queues for storing requests. The unit stalls execution if a new request is issued to it when it has not been allowed to return data from a prior instruction.</p> <p>For example, if the DR and BCU attempt to return results over the load bus in the same clock, the BCU wins the arbitration. This delays the DR result by one clock. If, simultaneously, the IS is attempting to issue another instruction to the data RAM, the DR stalls the processor for one clock.</p> |

Register bypassing eliminates a pipeline stall that would otherwise occur when one parallel processing unit is returning a result to a register over one port while, in the same clock, another unit is assessing the same register over a different port. Register bypassing logic constantly monitors all register addresses being written and read. If a register is being read and written in the same clock, bypass logic routes incoming data from the write port directly to the read port.

**A.2.3.4 Additional Scoreboarded Resources Due to the Data Cache**

In general, when the scheduler issues a group of instructions, the targeted parallel processing units immediately acknowledge receipt of instructions and the scheduler begins considering the next four unexecuted words of the instruction stream. There are, however, two conditions in which the execution of one or more of the instructions that the scheduler attempted to issue would be delayed. These conditions are: a *scoreboarded register* or a *scoreboarded resource*.

Because of the addition of the data cache to the MEM-side, there are a few additional scoreboarded resources on the i960 CF processor. A scoreboarded resource thwarts the scheduler’s attempt to issue an instruction. A resource is scoreboarded when it is needed to execute the instruction but is not available. The parallel processing units are the resources.

To maintain cache coherency, the IS does not issue any user-process stores to the BCU until all pending cacheable loads have returned to the data cache. The BCU is scoreboarded for user process stores when its queues contain one or more cacheable loads. DMA stores are allowed to be issued to the BCU. See section A.1.8.8, “BCU Queues and Cache Coherency” (pg. A-12).



A cacheable load is checked to see if it hits the data cache in the issue stage of the instruction pipeline and returns data to the register file in the execute state. If the load missed the data cache, it must be issued to the BCU to fetch the data from external memory. The missed load is not issued to the BCU until the execute state, which is also the issue stage for the next instruction in the pipeline. Because only one instruction can be issued to the BCU at a time, the BCU is scoreboarded for one clock cycle. Any instruction directed at the BCU in the clock cycle immediately following a data cache miss is scoreboarded for one cycle.

For cache misses, the data cache is a multi-clock processor which must interact with the BCU to return the load to the data cache. Because the data cache is a multi-clock processor, it must arbitrate for access to the return path to the data cache. There is a conflict between any new load or store being issued to the data cache and a load returning to the data cache from the BCU. In this case, the IS stalls for one clock while the returning load is written into the data cache. Table A-5 summarizes the additional scoreboarded resources due to the i960 CF processor's data cache unit.

**Table A-5. Scoreboarded Resource Conditions Due to the Data Cache**

| Condition                         | Description  |
|-----------------------------------|--|
| BCU queues contain cacheable load | One or more of the BCU queues contains a cacheable load. The machine does not issue any user process stores until all cacheable loads have returned to the data cache.   |
| BCU busy                          | The BCU can only support one access on every clock. If the BCU is processing a load from a cache miss on the previous cycle, it cannot process an instruction on the current cycle. The IS stalls issuance of the instruction to the BCU for one clock in this case. |
| Data cache busy                   | The data cache is a resource which is shared between returning loads from the BCU and the IS issuing loads/stores. The IS stalls issuance of a load or store for one clock so the returning load from the BCU can be written into the data cache.                    |

**A.2.4 Processing Units**

Once the IS issues a group of instructions, the appropriate processing units begin instruction execution in parallel with all other processor operations. The following sections describe each unit's pipelines and execution times of the instructions they process.

**A.2.4.1 Execution Unit (EU)**

The EU performs arithmetic, logical, move, comparison, bit and bit-field operations. The EU receives its instructions over the REG-machine bus and receives source operands over the *src1* and *src2* buses and returns its result over the *dst* bus.



The EU pipeline is shown in Figure A-8. In the clock in which an EU instruction is issued, the EU latches the source operands and begins performing the operation. In the following clock, the instruction completes and the result is written to the destination register. When an instruction immediately follows an EU operation that references the EU’s destination register, the new instruction is issued in the clock following the EU operation.

The EU directly executes the instructions listed in Table A-6. The EU is pipelined such that back-to-back EU operations execute at a one-clock sustained rate. The EU returns its result to the destination register in the clock following the clock in which the instruction was issued. If a fixup is needed during **shr**di execution, the processor executes a four-clock micro-flow. See section A.2.6, “Micro-flow Execution” (pg. A-36).

```
addo    g0, g1, g2
shlo    g3, g4, g5
subo    g5, g6, g7
shro    g8, g9, g10
```

|                              |                       |        |                         |                           |                         |                            |
|------------------------------|-----------------------|--------|-------------------------|---------------------------|-------------------------|----------------------------|
| <b>Instruction Scheduler</b> | Issue                 | addo   | shlo                    | subo                      | shro                    |                            |
| <b>EU Pipeline</b>           | Read src 1, src2      | g0, g1 | g3, g4                  | g5, g6                    | g8, g9                  |                            |
|                              | Execute and Write dst |        | $g2 \leftarrow g0 + g1$ | $g5 \leftarrow g4 \ll g3$ | $g7 \leftarrow g6 - g5$ | $g10 \leftarrow g9 \gg g8$ |

Figure A-8. EU Execution Pipeline

Table A-6. EU Instructions

|  |  |   |  |
|--|--|---|--|
| addo<br>addi<br>addc<br>subo<br>subi<br>subc<br><br>setbit<br>clrbit<br>notbit | shlo<br>shro<br>shri<br>shli<br>shr<br>eshro<br><br>alterbit<br>chkbit | mov<br>movl<br>cmpo<br>cmpi<br>cmpdeco<br>cmpdeci<br><br>scanbyte | and<br>andnot<br>notand<br>nand<br>or<br>nor<br>ornot<br>notor<br>xnor<br>xor<br>not<br>rotate |
|--|--|---|--|



**A.2.4.2 Multiply/Divide Unit (MDU)**

The MDU performs multiplication, division, remainder and modulo operations. The MDU receives its instructions over the REG-machine bus and source operands over the *src1* and *src2* buses and returns its result over the *dst* bus. Once the IS issues an MDU instruction, the MDU performs its operations in parallel with all other execution.

The MDU pipeline for the 32x32 **mulo** instruction is shown in Figure A-9. In the clock in which the multiply is issued, the MDU latches the source operands and begins the operation. The multiply completes and the result is written to the destination register in the fifth clock following the clock in which the instruction was issued. When an instruction immediately follows a multiply which references the multiply’s destination, the instruction is not issued until the clock in which the multiply result is returned. For example, an **addo** which follows a multiply and references the destination of the multiply is delayed until the fourth clock after the processor issues the multiply. This five-clock multiply latency is easily hidden; four to eight instructions could be placed between the multiply and add without increasing the total number of processor clocks used.

```
addo    g0, g1, g2
mulo    g3, g4, g5
addo    g5, g6, g7
```

|                              |                       |        |                       |     |     |     |     |                       |                       |
|------------------------------|-----------------------|--------|-----------------------|-----|-----|-----|-----|-----------------------|-----------------------|
| <b>Instruction Scheduler</b> | Issue                 | addo   | mulo                  | --- | --- | --- | --- | addo                  |                       |
| <b>EU Pipeline</b>           | Read src1, src2       | g0, g1 |                       |     |     |     |     | g5, g6                |                       |
|                              | Execute and Write dst |        | $g2 \leftarrow g0+g1$ |     |     |     |     |                       | $g7 \leftarrow g5+g6$ |
| <b>MDU Pipeline</b>          | Read src1, src2       |        | g3, g4                |     |     |     |     |                       |                       |
|                              | Execute               |        |                       |     |     |     |     |                       |                       |
|                              | Write dst             |        |                       |     |     |     |     | $g5 \leftarrow g3*g4$ |                       |

**Figure A-9. MDU Execution Pipeline**

The MDU incorporates a one-clock pipeline unless integer overflow faults are enabled. The IS can issue a new MDU instruction one clock before the previous result is written. For example, back-to-back 32x32 multiply throughput is four clocks per multiply versus a five-clock multiply latency. Figure A-10 shows the execution pipeline for back-to-back multiplies in which adjacent instructions do not have a register dependency between them.





```

addo    g0, g1, g2
mulo   g2, g3, g4
mulo   g5, g6, g7
addo   g8, g9, g10
    
```

| Instruction Scheduler | Issue                 | addo   | mulo                    | --- | --- | --- | mulo   | addo                    |                          |
|-----------------------|-----------------------|--------|-------------------------|-----|-----|-----|--------|-------------------------|--------------------------|
| EU Pipeline           | Read src1, src2       | g0, g1 |                         |     |     |     |        | g8, g9                  |                          |
|                       | Execute and Write dst |        | $g2 \leftarrow g0 + g1$ |     |     |     |        |                         | $g10 \leftarrow g8 + g9$ |
| MDU Pipeline          | Read src1, src2       |        | g2, g3                  |     |     |     | g5, g6 |                         |                          |
|                       | Execute               |        |                         |     |     |     |        |                         |                          |
|                       | Write dst             |        |                         |     |     |     |        | $g4 \leftarrow g2 * g3$ |                          |

Figure A-10. MDU Pipelined Back-To-Back Operations

The MDU directly executes instructions listed in Table A-7. The scheduler issues an MDU instruction in one clock. The table also shows the length of the execution stage (latency) for each instruction. Subsequent instructions not dependent upon MDU results are issued and executed in parallel with the MDU. If instructions in the table are issued back-to-back and they have no register dependency between them, the MDU pipeline improves throughput by one clock per instruction.

Table A-7. MDU Instructions

| Mnemonic | Issue Clocks | Result Latency | Back-to-Back Throughput (AC.om = 1) | Back-to-Back Throughput (AC.om = 0) |
|----------|--------------|----------------|-------------------------------------|-------------------------------------|
| muli     | 32x32        | 1              | 5                                   | 4                                   |
|          | 16x32        | 1              | 3                                   | 2                                   |
| mulo     | 32x32        | 1              | 5                                   | 4                                   |
|          | 16x32        | 1              | 3                                   | 2                                   |
| emul     | 32x32        | 1              | 6                                   | 5                                   |
|          | 16x32        | 1              | 3                                   | 2                                   |
| divi     | 13           | 37             | 36                                  | 36                                  |
| divo     | 3            | 36             | 35                                  | 35                                  |
| ediv     | 3            | 36             | 35                                  | 35                                  |
| remi     |              |                |                                     |                                     |
| remo     |              |                |                                     |                                     |
| modi     |              |                |                                     |                                     |

A



**A.2.4.3 Data RAM (DR)**

On-chip data RAM (DR), described in section 2.5.4, “Internal Data RAM” (pg. 2-12), is single-ported and 128-bits wide to support accesses of up to one quad-load or quad-store per clock. The DR receives instructions over the MEM-machine bus, stores addresses over the 32-bit Address Out bus and stores data over the 128-bit store bus. The DR returns data over the 128-bit load bus.

The one-clock DR pipeline for reads is shown in Figure A-11. When the IS issues a load from the DR, load data is written to the destination register in the following clock.

An instruction which immediately follows a load from the DR and references the load destination cannot execute in the same clock as the load. As shown in the figure, the instruction is issued in the clock in which the load data is returning.

Table A-8 lists the instructions executed directly in most addressing modes (without micro-flow execution) using the DR. As seen in Figure A-11, if these instructions are issued back-to-back, they execute at a one-clock sustained rate, with or without register dependencies.

```

addo    g16, g0, g0
ldq     (g0), g4
addo    g4, g5, g6
ldt     (g7), g8
ldq     (g8), g0
    
```

| Instruction Scheduler | Issue                 | addo   | ldq      | addo ldt | ldq      |
|-----------------------|-----------------------|--------|----------|----------|----------|
| EU Pipeline           | Read src1, src2       | 16, g0 |          | g4, g5   |          |
|                       | Execute and Write dst |        | g0←g0+16 |          | g6←g4+g5 |

**Figure A-11. Data RAM Execution Pipeline**

**Table A-8. Data RAM Instructions**

| Load Latency = 1 clock | Store Latency = 1 clock |
|------------------------|-------------------------|
| ld                     | st                      |
| ldob                   | stob                    |
| ldib                   | stib                    |
| ldos                   | stos                    |
| ldis                   | stis                    |
| ldl                    | stl                     |
| ldt                    | stt                     |
| ldq                    | stq                     |



### A.2.4.4 Address Generation Unit (AGU)

The AGU contains a 32-bit parallel shifter-adder to speed memory address calculations. It also directly executes the **lda** instruction. The AGU receives instructions over the MEM-machine bus and offset and displacement values over the address out bus from the IS. The AGU reads the global and local registers over the 32-bit base bus register port and writes the registers over the 128-bit load bus.

The AGU calculates an effective address (*efa*) which is either written to a destination register in (the case of an **lda** instruction) or used as a memory address (in the case of loads, stores, extended branches or extended calls). When an **lda** instruction is issued, the AGU returns the *efa* to the destination register in the following clock for most addressing modes. An instruction which immediately follows the **lda** and references the **lda** destination is not issued in the same clock as the **lda**. As shown in Figure A-12, it is issued in the clock in which **lda** is writing the destination register.

Table A-9 lists the **lda** addressing mode combinations that the AGU executes directly. As seen in the figure, if **lda** instructions are issued back-to-back using one of the addressing modes in the table, the instructions execute at a one-clock sustained rate with or without register dependencies.

```
addo    16, g0, g0
lda     16 (g0), g4
addo    g4, g5, g6
lda     16 [g7 * 4], g8
lda     16 (g8), g0
```

| Instruction Scheduler | Issue                        | addo   | lda      | addo lda | lda          |          |
|-----------------------|------------------------------|--------|----------|----------|--------------|----------|
| EU Pipeline           | Read src1, src2              | 16, g0 |          | g4, g5   |              |          |
|                       | Execute and Write dst        |        | g0←g0+16 |          | g6←g4+g5     |          |
| AGU Pipeline          | Read over Base Bus           |        | g0       | g7       | g8           |          |
|                       | Execute and Write over Ldbus |        |          | g4←g0+16 | g8←(g7*4)+16 | g0←g8+16 |

Figure A-12. The **lda** Pipeline

Table A-9. AGU Instructions

| Mnemonic   | Issue Clocks | Addressing Mode  | Result Latency Clocks |
|------------|--------------|--|-----------------------|
| <b>lda</b> | 1            | offset<br>disp<br>(reg)<br>offset(reg)<br>disp(reg)<br>disp[reg * scale] | 1                     |



#### A.2.4.5 Effective Address (*efa*) Calculations

The AGU calculates the *efa* for instructions which require one. When the addressing mode specified by an instruction is the *offset*, *disp* or (*reg*) mode, the AGU generates the *efa* in parallel with the instruction's issuance. As shown in the previous pipeline figure for the DR (Figure A-11), load and store instructions begin immediately for these addressing modes with no delay for address generation. See section A.2.6, "Micro-flow Execution" (pg. A-36) for a description of how other addressing modes are handled.

#### A.2.4.6 Bus Control Unit (BCU)

The BCU executes memory operations for load and store instructions, instruction fetches, micro-flows and DMA operations. It executes memory load requests in two clocks (zero wait states) and returns a result on the third clock. Using address pipelining and on-chip request queuing, the BCU can accept a load or store from the IS every clock and return load data every clock. The BCU receives instructions over the MEM-machine bus, stores addresses over the 32-bit address out bus and stores data over the 128-bit store bus. The BCU returns data over the 128-bit load bus.

The BCU receives a load address during the "issue" clock. The address is placed on the system bus during the next clock (the first BCU execute stage). The system returns data at the end of the following clock (the second BCU execute stage). On the next clock the BCU writes the data to the destination register. This write is bypassed to the REG-side and MEM-side source buses and the scoreboarded instruction is issued in the same clock.

The zero wait state load causes a two clock execution delay of the next instruction because the load data is referenced immediately after the load is issued. If the memory system has wait states, the load data delay would be longer. If the load is advanced in the code such that it is separated from the instruction which uses the data, the load delay could be completely overlapped with the execution of other instructions.

Store instruction execution would proceed as does the load, except that there would be no return clock and no instructions could be stalled due to a scoreboarded register.

Table A-10 lists instructions that the i960 CA processor's BCU executes directly. For each instruction that requires multiple reads (such as **ldq**) the BCU buffers the return data until all data is returned. This optimization reduces the internal load bus overhead to the minimum, giving more clocks to the processor to access the DR and perform **lda** operations while external loads are in progress. The table is valid when offset, displacement or indirect memory addressing modes are used over an external bus with the following characteristics:

$$N_{XAD} = N_{XDD} = N_{XDA} = 0, \text{ Burst On, Pipelining On, Ready Disabled}$$

For other addressing modes, see section A.2.6, "Micro-flow Execution" (pg. A-36).



If instructions listed in the table are issued back-to-back with no register dependencies, they will execute at a rate of one instruction per clock until the BCU queues are full. Once the queues are full, further back-to-back BCU instructions execute at the bus bandwidth. Figure A-13 shows back-to-back loads being executed.

**Table A-10. BCU Instructions for the i960 CA Processor**

| Mnemonic  | Issue Clocks | Result Latency Clocks | Back-to-Back Throughput |
|---|--------------|-----------------------|-------------------------|
| <b>ld</b><br><b>ldob</b><br><b>ldib</b><br><b>ldos</b><br><b>ldis</b> | 1            | 3                     | 1                       |
| <b>ldl</b>  | 1            | 4                     | 2                       |
| <b>ldt</b>  | 1            | 5                     | 3                       |
| <b>ldq</b>  | 1            | 6                     | 4                       |
| <b>st</b><br><b>stob</b><br><b>stib</b><br><b>stos</b><br><b>stis</b> | 1            | N/A                   | 2                       |
| <b>stl</b>  | 1            | N/A                   | 3                       |
| <b>stt</b>  | 1            | N/A                   | 4                       |
| <b>stq</b>  | 1            | N/A                   | 5                       |

To allow programs to issue load requests before the data is needed — and thus decouple memory speeds from instruction execution — the BCU contains three queue entries. Each entry stores all the information needed for a memory request:

- For loads, the BCU contains the source address, destination register number and load type
- For stores, BCU contains the destination address, store type and the store data

If a **stq** is executed, all four registers are written to the BCU queue in one clock. The BCU performs the actual bus request without taking any further clocks from instruction execution. BCU queues maintain memory requests in order. The requests are executed on the bus in the order that they are issued from the instruction stream.



```
ld      (g0), g1
ld      (g2), g3
ld      (g4), g5
addo   g1, g6, g7
```

|                              |                       |    |    |      |         |          |         |  |
|------------------------------|-----------------------|----|----|------|---------|----------|---------|--|
| <b>Instruction Scheduler</b> | Issue                 | ld | ld | ld   | addo    |          |         |  |
| <b>BCU Pipeline</b>          | Address Out bus       | g0 | g2 | g4   |         |          |         |  |
|                              | St bus                |    |    |      |         |          |         |  |
|                              | External Address Bus  |    | g0 | g2   | g4      |          |         |  |
|                              | External Data Bus     |    |    | (g0) | (g2)    | (g4)     |         |  |
|                              | LD Bus                |    |    |      | g1←(g0) | g3←(g2)  | g5←(g4) |  |
| <b>EU Pipeline</b>           | Read src1, src2       |    |    |      | g1, g6  |          |         |  |
|                              | Execute and Write dst |    |    |      |         | g7←g1+g6 |         |  |

**Figure A-13. Back-to-Back BCU Accesses**

When the DMA controller is enabled, one of the three queue entries is dedicated for DMA operations. This improves DMA performance and latency at the expense of loads and stores. See CHAPTER 13, DMA CONTROLLER.

**A.2.4.7 Control Pipeline**

The IS directly executes program flow control instructions. Branches take two clocks to execute in the CTRL pipeline; however, the IS is able to see branches as many as four instructions ahead of the current instruction pointer. This allows the scheduler to issue the branch early and, in most cases, execute the branch without inserting a dead clock in the REG and MEM instruction streams.

Table A-11 lists the instructions that the IS executes directly, without the aid of micro-flows. For information on other control flow instructions, see section A.2.6, “Micro-flow Execution” (pg. A-36).

**A.2.4.8 Unconditional Branches**

Figure A-15 shows the IS issue stage and the CTRL pipeline for the case where the branch target is another branch, disabling the IS’s ability to look ahead. The IS issues the branch in one clock; the branch is executed in the next clock. The branch target is another branch, which the scheduler issues immediately. Hence, branch instructions have a two-clock sustained rate when issued back-to-back.



Table A-11. CTRL Instructions

| Mnemonic  | Issue Clocks | Latency Clocks | Back-to-Back Throughput Clocks |
|---|--------------|----------------|--------------------------------|
| bbe<br>bne<br>bl<br>ble<br>bg<br>bge<br>bo<br>bno | 1            | 2              | 2                              |

w: b      x  
 ...  
 x: b      y  
 ...  
 y: b      z  
 ...  
 z: b      w

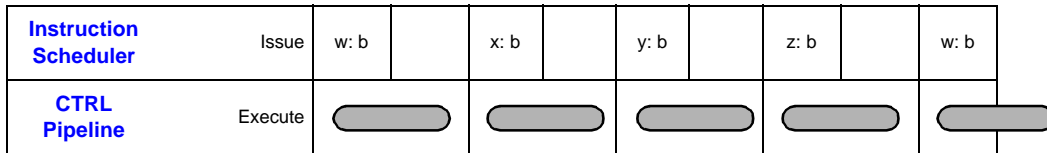


Figure A-14. CTRL Pipeline for Branches to Branches

Figures A-15, A-16 and A-17 show the IS issue stage and the CTRL pipeline for each case of possible IS branch lookahead detection. Assuming that the IS can see four instructions every clock from the instruction cache, the branch can be in the first, second or third group of instructions seen.

An *executable group* of instructions is a group of sequential instructions in the currently visible quad-word which can be issued in the same clock. See section A.2, “PARALLEL INSTRUCTION PROCESSING” (pg. A-14).

Figure A-15 shows the cases where a branch, when first seen by the IS, is in the first executable group of instructions. The IS issues the branch immediately, along with the first one (or two) instruction(s) ahead of it. Since the branch takes two clocks in the CTRL pipeline to execute, a one-clock break in the IS’s ability to issue instructions occurs. On the next clock, the IS issues a new group of instructions from the branch target.



In the figure, two other instructions were issued simultaneously with the branch. Hence, the branch could be said to have taken one clock to execute. When the branch is the first instruction in the group (the branch is a branch target) no other instructions are issued in parallel with the branch and it takes a full two clocks to execute (as seen in Figure A-15).

```

        b           x
        ...
x:      addo       g0, g1, g2
        lda       2(g3), g4
        b         y
        ...
y:      addo       g5, g6, g7
        lda       2(g8), g9
    
```

| Instruction Scheduler | Issue                        |  | addo<br>lda<br>b | —                       | addo<br>lda |                         |  |  |
|-----------------------|------------------------------|--|------------------|-------------------------|-------------|-------------------------|--|--|
| <b>CTRL Pipeline</b>  | Execute                      |  |                  |                         |             |                         |  |  |
| <b>EU Pipeline</b>    | Read src1, src2              |  | g0, g1           |                         | g5, g6      |                         |  |  |
|                       | Execute and Write dst        |  |                  | $g2 \leftarrow g0 + g1$ |             | $g7 \leftarrow g5 + g6$ |  |  |
| <b>AGU Pipeline</b>   | Read over Base Bus           |  | g3               |                         | g8          |                         |  |  |
|                       | Execute and Write over Ldbus |  |                  | $g4 \leftarrow 2 + g3$  |             | $g9 \leftarrow g8 + 2$  |  |  |

**Figure A-15. Branch in First Executable Group**

Figure A-16 shows the case where a branch, when first seen by the IS, is in the second executable group (B) of instructions in the rolling quad-word, not the first executable group (A) which is about to be issued. The IS issues the branch immediately, along with the first group of instructions ahead of it (A). Since the branch takes two clocks in the CTRL pipeline to execute, there is no break in the IS’s ability to issue instructions. On the next clock, the IS issues a new group of instructions from the branch target.

In the figure, two other instructions were issued simultaneously with the branch and one instruction was issued during the clock in which the branch was executing. Hence, it can be said that this branch takes zero clocks to execute.

Figure A-17 shows the case where a branch, when first seen by the IS, is in the third executable group (C) of instructions of the rolling quad-word, not the first executable group (A) which is about to be issued. The IS issues group A, then issues the branch and group B simultaneously. Since the branch takes two clocks in the CTRL pipeline to execute, there is no break in the IS’s ability to issue instructions. On the clock following the issuance of group B, the IS issues a new group of instructions from the branch target.





```

b      x
...
x:    addo   g0, g1, g2    }A
      lda   2(g3), g4    }
      lda   2(g5), g6    }B
      b     y
y:    ...
      addo   g7, g8, g9
      lda   2(g10), g11
  
```

|                              |                              | Group: A |                  | B        |             |           |  |
|------------------------------|------------------------------|----------|------------------|----------|-------------|-----------|--|
| <b>Instruction Scheduler</b> | Issue                        |          | addo<br>lda<br>b | lda      | addo<br>lda |           |  |
| <b>CTRL Pipeline</b>         | Execute                      |          |                  |          |             |           |  |
| <b>EU Pipeline</b>           | Read src1, src2              |          | g0, g1           |          | g7, g8      |           |  |
|                              | Execute and Write dst        |          |                  | g2←g0+g1 |             | g9←g7+g8  |  |
| <b>AGU Pipeline</b>          | Read over Base Bus           |          | g3               | g5       | g10         |           |  |
|                              | Execute and Write over Ldbus |          |                  | g4←g3+2  | g6←g5+2     | g11←g10+2 |  |

Figure A-16. Branch in Second Executable Group



```

b      x
...
x:    lda  2(g3), g4      ← A
      addo g0, g1, g2    ← B
      addo g5, g6, g7    ← C
      b    y
...
y:    addo g8, g9, g10
      lda  2(g11), g12
    
```

| Group:                       |                              | A   | B                      | C                       |                         |                          |  |
|------------------------------|------------------------------|-----|------------------------|-------------------------|-------------------------|--------------------------|--|
| <b>Instruction Scheduler</b> | Issue                        | lda | addo<br>b              | addo                    | addo<br>lda             |                          |  |
| <b>CTRL Pipeline</b>         | Execute                      |     |                        |                         |                         |                          |  |
| <b>EU Pipeline</b>           | Read src1, src2              |     | g0, g1                 | g5, g6                  | g8, g9                  |                          |  |
|                              | Execute and Write dst        |     |                        | $g2 \leftarrow g0 + g1$ | $g7 \leftarrow g5 + g6$ | $g10 \leftarrow g8 + g9$ |  |
| <b>AGU Pipeline</b>          | Read over Base Bus           | g3  |                        |                         | g11                     |                          |  |
|                              | Execute and Write over Ldbus |     | $g4 \leftarrow g3 + 2$ |                         |                         | $g12 \leftarrow g11 + 2$ |  |

Figure A-17. Branch in Third Executable Group

**A.2.4.9 Conditional Branches**

When the IS sees a conditional branch instruction, the condition codes are sometimes not yet determined. For example, a conditional branch which immediately follows a compare instruction cannot be allowed to complete execution until the result of the comparison is known. However, the processor begins to execute the branch based upon the branch prediction bit set by the programmer for that branch.

When one or more executable instruction groups separate the conditional instruction from the instruction that changed the condition code, the condition code will have already settled in the pipeline by the time the prefetch mechanism sees the conditional instruction. This situation allows the branch to execute in zero clock cycles, as described in Figure A-17.

If the conditional instruction and the instruction that sets the condition codes are in the same executable group or in consecutive groups, the condition code is not valid when the IS sees the branch; a guess is required. If the prediction turns out to be correct, the branch executes in its normal amount of time, as described in the previous section. If the prediction is wrong, the pipeline is flushed. Any erroneously started single- or multiple-cycle instructions are killed and the branch executes as if there had been no lookahead or prediction. In other words:



- the branch takes two clocks out of the IS's issue stage if it is in the same executable group as the instruction which modified the condition codes; or
- the branch takes one clock if it is in the executable group adjacent to the group that modifies the condition codes.

## A.2.5 Instruction Cache And Fetch Execution

The instruction cache provides three or four consecutive opcode words to the IS on every clock. This capability allows the processor to dispatch instructions from the processor's sequential instruction stream to multiple independent parallel processing units. When a cache miss occurs or is about to occur, the Instruction Fetch Unit issues instruction fetch requests to the BCU.

### A.2.5.1 Instruction Cache Organization

The i960 Cx processors' instruction cache is a two-way set associative cache, organized in two sets of eight-word lines.

- The i960 CA processor cache is 1 KByte, organized as two sets of 16 eight-word lines.
- The i960 CF processor cache is 4 KBytes, organized as two sets of 64 eight-word lines.

Each line is composed of four two-word blocks which can be replaced independently.

On every clock, the cache accesses one or two lines and multiplexes the correct three or four words to the IS. Three words are valid if the requested address is for an odd word in memory ( $A2=1$ ). Four words are valid if the requested address is for an even word of memory ( $A2=0$ ).

The i960 CA processor's instruction cache supports pre-loading and locking of none, half or all of the instruction cache. However, only interrupt procedures can be locked into the cache. The cache locking scheme is improved on the i960 CF processor and has fewer restrictions. Any section of code can be locked into half of the instruction cache, not just the interrupt procedures.

When the i960 CF processor executes **sysctl** (modes 100, 110) with a command to lock the instruction cache, one way of the two-way set associative cache is pre-loaded and locked from the specified address. The other half of the instruction cache now functions as a 2 Kbyte direct-mapped instruction cache except for those instructions that **sysctl** locks. (The unlocked portion of the i960 CA processor's instruction cache functions as two-way set associative.) This mode of operation continues until the cache mode is changed by the next **sysctl** instruction. As on the i960 CA processor, the invalidate instruction cache **sysctl** message invalidates both the locked and unlocked halves of the cache.

The instruction scheduler checks all ways of the cache for every instruction fetched. If an instruction is not found, it is fetched from external memory and loaded into the unlocked portion of the instruction cache.

**A**



**Table A-12. Cache Configuration Modes**

| Mode Field       | Mode Description  | CA                   | CF                    |
|------------------|---|----------------------|-----------------------|
| 000 <sub>2</sub> | normal cache enabled  | 1 Kbyte              | 4 Kbytes              |
| XX1 <sub>2</sub> | full cache disabled   | 1 Kbyte              | 4 Kbytes              |
| 100 <sub>2</sub> | Load and lock full cache (execute off-chip)                     | 1 Kbyte <sup>1</sup> | 4 Kbytes <sup>2</sup> |
| 110 <sub>2</sub> | Load and lock half the cache; remainder is normal cache enabled | 512 bytes            | 2 Kbytes              |
| 010 <sub>2</sub> | Reserved  | 1 Kbyte              | 4 Kbytes              |

**NOTES:**

1. On the CA, only interrupt procedures can execute in the locked portion of the cache.
2. On the CF, interrupt procedures and other code can operate in the locked portion of the cache.

**A.2.5.2 Fetch Strategy**

When any of the three or four words presented to the scheduler are invalid, a cache miss is signaled and an instruction fetch is issued. The Instruction Fetch Unit makes the fetch and prefetch decisions.

Since the cache supports two-word and quad-word replacement within a line, instruction fetches can be issued in either size. The conditions of the cache miss determine which fetch is issued. Table A-13 describes the fetch decision.

**Table A-13. Fetch Strategy**

| Words Provided To Scheduler |      |      |       | Fetch Initiated                        |  |
|-----------------------------|------|------|-------|--|--|
| IP                          | IP+4 | IP+8 | IP+12 | A3:2 of requested IP = 0X <sub>2</sub> | A3:2 of requested IP = 1X <sub>2</sub>       |
| Hit                         | Hit  | Hit  | Hit   | no fetch                               | no fetch                                     |
| Hit                         | Miss | Hit  | Hit   | fetch two words at IP                  | fetch two words at IP                        |
| Miss                        | Hit  | Hit  | Hit   |  |  |
| Miss                        | Miss | Hit  | Hit   |  |  |
| Hit                         | Hit  | Hit  | Miss  | fetch two words at IP+8                | fetch two words at IP+8                      |
| Hit                         | Hit  | Miss | Hit   |  |  |
| Hit                         | Hit  | Miss | Miss  |  |  |
| All other cases             |      |      |       | fetch four words at IP                 | fetch two words at IP and four words at IP+8 |

**A.2.5.3 Fetch Latency**

The Instruction Fetch Unit initiates an instruction fetch by requesting quad-word or long-word loads from the BCU. These fetches differ from actual instruction stream loads in two ways: load destination and load data buffering.



First, the load destination of an instruction fetch is the instruction fetch buffer, not the register file. Since fetch data goes directly from the BCU to the instruction fetch buffer and IS, the scheduler can issue fetched instructions during the clock after they are read from external memory.

Second, to reduce fetch latency, the BCU buffers fetch data differently than a regular load instruction. Instead of buffering four words of instructions before sending data to the fetch unit, the BCU sends each word as it is received over the bus. If the fetches are from 8- or 16-bit memory, the BCU collects 32 bits before sending the word to each fetch unit.

Figure A-18 shows the execution of a two-word fetch that resulted from a cache miss. The fetch unit detects the cache miss at the end of the clock in which instructions would be issued had a hit occurred. The fetch unit issues the instruction fetch in the following clock. Assuming that the BCU is not busy with another operation, the request begins on the external bus in the next clock. The first word of the fetch is returned to the fetch unit in the clock in which it is received from the memory system; the IS attempts to issue the instruction to an execution unit in that same clock. The remaining words of a fetch are returned as they are received from the system (i.e., one each clock).

If the fetch request is the result of a prefetch decision, the IS is not stalled unless it needs an instruction from the prefetch request.

If the processor is executing straight-line code which always misses the cache, the IS is only able to issue instructions at a one-instruction-per-clock rate. It is never able to see multiple instructions in one clock. The bus bandwidth of the memory subsystem containing the code limits the application's performance.

```

b      y
...
y:    addo  g0, g1, g2 ← Cache Miss
      subo  g3, g4, g5
    
```

|                              |                       |  |            |            |     |        |        |          |          |  |
|------------------------------|-----------------------|--|------------|------------|-----|--------|--------|----------|----------|--|
| <b>Instruction Scheduler</b> | Issue                 |  | y: —<br>—  | — —        | — — | — —    | addo   | subo     |          |  |
| <b>CTRL Pipeline</b>         | Execute               |  | Cache Miss |            |     |        |        |          |          |  |
| <b>BCU Pipeline</b>          | Address Out bus       |  |            | Fetch Miss |     |        |        |          |          |  |
|                              | St bus                |  |            |            |     |        |        |          |          |  |
|                              | External Address Bus  |  |            |            | A   |        |        |          |          |  |
|                              | External Data Bus     |  |            |            |     | D addo | D subo |          |          |  |
|                              | Ld Bus                |  |            |            |     | D addo | D subo |          |          |  |
| <b>EU Pipeline</b>           | Read src1, src2       |  |            |            |     |        | g0, g1 | g3, g4   |          |  |
|                              | Execute and Write dst |  |            |            |     |        |        | g2←g0+g1 | g5←g4-g3 |  |

Figure A-18. Fetch Execution

**A.2.5.4 Cache Replacement**

Data fetched as a result of a cache miss is written to the cache when and if the fetched data is requested by the IS. This optimization keeps unexecuted prefetched data from taking up valuable cache space.

As the fetches come in from the BCU, the fetch unit stores incomplete fetch blocks in a queue. If the IS requests one or more instructions which are in the queue, the fetch unit satisfies the queue request. If the queue entry that the scheduler requests contains a full group (two words) of instructions, the valid groups in the queue are also written to the cache in the same clock that they are given to the scheduler. The least-recently used set is updated.

**A.2.6 Micro-flow Execution**

The i960 Cx processors’ parallel processing units directly execute about half of the processor’s instructions. The processor services the remaining complex instructions by executing a sequence of simple instructions from an on-chip ROM. Complex instructions are detected in the clock in which they are fetched. This information becomes part of the instruction encoding stored in the instruction fetch unit queue and/or instruction cache.



Micro-flow instruction sequences are written to enable the parallel processing units to perform the required function as fast as possible. Micro-flows use instructions described in prior sections of this appendix (machine types REG, MEM and CTRL) and some special parallel circuitry to carry out the complex instructions. An instruction which cannot be directly issued to a parallel processing unit is said to have the machine type  $\mu$ .

#### A.2.6.1 Invocation and Execution

Invoking a micro-flow can be considered analogous to the processor's execution of an unconditional branch into the on-chip ROM. However, pre-decoding and optimized lookahead logic makes the micro-flow invocation more efficient than a branch instruction.

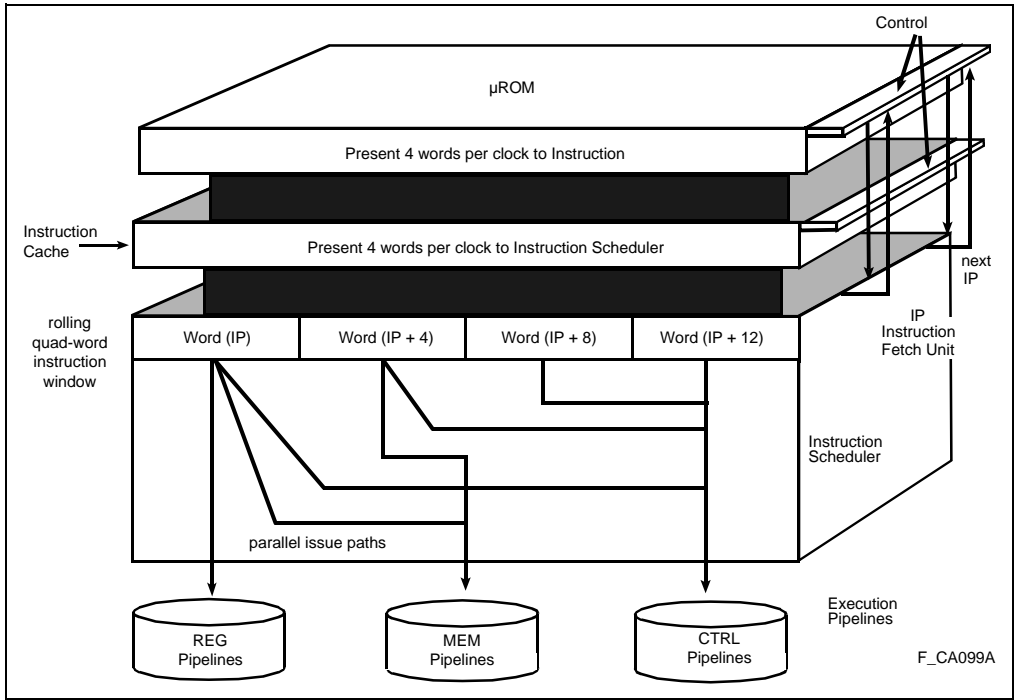
While the IS is issuing one group of instructions, parallel decode circuitry checks to see if the *next* executable instruction is a  $\mu$  instruction (Figure A-19). If so, the opcode words presented to the IS in the *next* clock come from the on-chip ROM location that contains the micro-flow for the detected complex instruction. The IS actually never attempts to issue a complex encoding. The processor detects the encoding when the instruction is fetched, then traps during the clock in which the instruction is presented to the IS.

Generally, no clocks are lost when switching to a micro-flow. However, two conditions can defeat the lookahead logic:

- branches to REG-, CTRL- or COBR-format instructions which are implemented as micro-flows ( $\mu$ ); or
- cache misses from straight-line code execution.

Under these conditions, the switch to on-chip ROM causes a one-clock break in the IS's ability to issue instructions.

Complex instructions encoded with the MEM-format do not require lookahead detection to trap to the ROM without overhead. Therefore, MEM-format instructions of machine type  $\mu$  do not see a one-clock performance loss even when lookahead logic is defeated. Furthermore, micro-flows return to general execution with no overhead; back-to-back micro-flows do not incur the one-clock defeated lookahead penalty.



**Figure A-19. Micro-flow Invocation**

When micro-flows execute, they consume the instruction scheduler’s activity. From the first clock through the last clock of a micro-flow, the IS is typically issuing two instructions per clock. MEM-side micro-flows — such as loads and stores — can be issued in parallel with REG-side instructions. Performance of micro-flowed instructions is measured by the number of clocks taken to issue instructions.

**A.2.6.2 Data Movement**

Data movement instructions supported as micro-flows include the triple and quad-word register move instructions and the **lda**, load and store instructions which use complex addressing modes.

**movt** and **movq** each take two clocks to execute.

**lda** takes two clocks to execute for the  $(reg)[reg * scale]$  and  $disp(reg)[reg * scale]$  addressing modes and can be issued in parallel with an instruction of machine type REG. **lda** using the  $disp(IP)$  addressing mode takes four clocks to execute and can be issued in parallel with a machine type REG instruction. The AGU executes **lda** directly for all other addressing modes.





Load and store instructions are summarized in Table A-14 and Table A-15. The number of clocks shown is the *additional* number of issue clocks consumed for address calculation prior to the load or store being issued to the BCU or DR. These instructions can be issued in parallel with a machine type REG instruction. To find the result latency of the BCU or DR, see the appropriate section earlier in this appendix.

**Table A-14. Load Micro-flow Instruction Issue Clocks**

| The following load instructions consume <b>n</b> additional issue clocks for address calculation before initiating a load request to the BCU or DR, where <b>n</b> for each addressing mode is as follows: |   |  |          |
|--|---|--|----------|
| Mnemonic   | disp(reg)<br>offset(reg)<br>disp[reg * scale] | (reg)[reg * scale]<br>disp(reg)[reg * scale] | disp(IP) |
| <b>ld, ldob, ldib, ldos, ldis, ldl, ldt, ldq</b>   | 1   | 2  | 4        |

**NOTE:** *offset, disp* and *(reg)* memory addressing modes incur no address calculation overhead.

### A.2.6.3 Bit and Bit Field

**scanbit, spanbit, extract** and **modify** are executed as micro-flows. Table A-16 lists their execution times. For these instructions, the IS issues **n** clocks of instructions in place of the single-word i960 Cx processor instruction encoding, where **n** is shown in the table.

**Table A-15. Store Micro-flow Instruction Issue Clocks**

| The following store instructions consume <b>n</b> additional issue clocks for address calculation prior to initiating a store request to the BCU or DR, where <b>n</b> for each addressing mode is as follows: |   |  |          |
|--|---|--|----------|
| Mnemonic   | disp(reg)<br>offset(reg)<br>disp[reg * scale] | (reg)[reg * scale]<br>disp(reg)[reg * scale] | disp(IP) |
| <b>st, stob, stib, stos, stis, stl, stt, stq</b>   | 1   | 2  | 4        |

**NOTE:** *offset, disp* and *(reg)* memory addressing modes incur no address calculation overhead.





**Table A-16. Bit and Bit Field Micro-flow Instructions**

| Mnemonic | Execution Clocks (n) |
|----------|----------------------|
| scanbit  | 1                    |
| spanbit  | 2                    |
| extract  | 4                    |
| modify   | 3                    |

**A.2.6.4 Comparison**

**test\*** instructions are executed as micro-flows. Execution time depends upon condition code validity and prediction bit settings. When condition codes are valid or the prediction bit is set correctly, a **test\*** instruction takes one issue clock if its correct result is a 1 and two issue clocks if its correct result is a 0. Otherwise, the **test\*** instruction takes three issue clocks to execute.

**A.2.6.5 Branch**

Compare and branch, extended branch, branch and link and extended branch and link instructions are implemented with micro-flows.

**cmpib\*** and **cmpob\*** instructions take one issue clock if the prediction was correct and two issue clocks if the prediction was incorrect, assuming a cached branch target.

**bal** takes two issue clocks to execute, assuming a cache hit.

**bx** and **balx** are summarized in Table A-17. The number of clocks shown is the total number of issue clocks consumed by the instruction prior to the code at the branch target being issued. Times shown assume instruction cache hits and a DR-based link target. These instructions may be issued in parallel with a machine-type R instruction.

**Table A-17. bx and balx Performance**

| The following instructions consume <b>n</b> issue clocks before target code is issued, where <b>n</b> for each addressing mode is as follows: |  |  |          |
|---|--|--|----------|
| Mnemonic  | disp<br>offset<br>(reg)<br>disp(reg)<br>offset(reg)<br>disp[reg * scale] | (reg)[reg * scale]<br>disp(reg)[reg * scale] | disp(IP) |
| <b>bx, balx</b>   | 4  | 4  | 6        |



**A.2.6.6 Call and Return**

Procedure call, return and system procedure call instructions are implemented as micro-flows. **call** consumes four issue clocks when the target is cached and a register cache location is available. When a frame spill is required, an additional 22 issue clocks are consumed in a zero-wait-state system before the target code begins execution. The worst-case memory activity for a call with a frame spill and a cache miss is one quad-word instruction fetch followed by four quad-word stores. Wait states in the instruction fetch directly impact call speed, while wait states in the frame stores are decoupled from internal execution by the BCU queues.

**ret** consumes four issue clocks when the target and the previous register set are both cached. When a frame fill is required, an additional 38 issue clocks are consumed in a zero-wait-state system before the target code begins execution. The worst-case memory activity for a return with a frame fill and a cache miss is four quad-word reads followed by one quad-word fetch. Wait states in the instruction fetch or the frame fill directly impact return speed.

**calls** consumes up to 56 issue clocks if the call is to a supervisor procedure. If the call is to a non-supervisor procedure, **calls** takes 38 issue clocks. These times assume an available register cache location and a cached target. During **calls** execution, the processor accesses the system procedure table with a single-word read and a long-word read. The presence of several wait states in these reads directly affects the instruction’s performance. The impact of non-cached target code or a frame spill on the **calls** instruction is identical to the impact on the **call** instruction.

**callx** timing is similar to **call** instruction timing with the exception of issue clocks. Table A-18 shows total issue clocks for **callx**.

**Table A-18. callx Performance**

| The following instruction consumes <b>n</b> issue clocks before target code is issued, where <b>n</b> for each addressing mode is as follows: |  |  |          |
|---|--|--|----------|
| <b>Mnemonic</b>   | disp<br>offset<br>(reg)<br>disp(reg)<br>offset(reg)<br>disp[reg * scale] | (reg)[reg * scale]<br>disp(reg)[reg * scale] | disp(IP) |
| <b>callx</b>  | 7  | 9  | 9        |

Times shown assume instruction cache hits.



### A.2.6.7 Conditional Faults

**fault\*** instructions are implemented with micro-flows and require one issue clock if the prediction bit is correct and no fault occurs. If the prediction bit is incorrect and no fault occurs, the instructions require two issue clocks. The time it takes to enter a fault handler varies greatly depending upon the state of the processor's parallel processing units.

### A.2.6.8 Debug

**mark** and **fmark** are implemented with micro-flows. **mark** takes one issue clock if no trace fault is signaled. If a trace fault is signaled or **fmark** is executed, the processor performs an implicit call to the trace fault handler. As with conditional faults, the time required to enter a fault handler varies greatly.

### A.2.6.9 Atomic

Atomic instructions are implemented with micro-flows. **atadd** takes seven issue clocks and **atmod** takes eight issue clocks to execute with an idle bus in a zero-wait state system. Memory wait states directly affect execution speed.

### A.2.6.10 Processor Management

Processor management instructions implemented as micro-flows include: **modpc**, **modac**, **modtc**, **syncf**, **flushreg**, **sdma**, **udma** and **sysctl**.

|                 |   |
|-----------------|---|
| <b>modpc</b>    | requires 17 clocks to execute if process priority is changed and 12 clocks if process priority is not changed.  |
| <b>modac</b>    | requires 9 clocks.  |
| <b>modtc</b>    | requires 15 clocks.   |
| <b>syncf</b>    | takes 4 issue clocks if there are no possible outstanding faults. Otherwise, the instruction locks the IS until it is certain that no prior instruction will fault.                   |
| <b>flushreg</b> | requires 24 clocks for each frame that is flushed. This translates to 120 cycles to flush five frames. Wait states in the memory being written affect this instruction's performance. |
| <b>sdma</b>     | executes in 22 clocks. In the case of back-to-back <b>sdma</b> instructions, 40 clocks are required.  |
| <b>udma</b>     | requires 4 clocks.  |
| <b>sysctl</b>   | Timings shown in Table A-19 assume a zero wait-state memory system.   |



**Table A-19. sysctl Performance**

| Message                     | Message Type | Issue Clocks  |
|-----------------------------|--------------|---|
| Request Interrupt           | 00H          | 37 + bus wait states  |
| Invalidate Cache            | 01H          | 38  |
| Configure Cache             | 02H          | 52 with 1 Kbyte cache enabled;<br>48 with 1Kbyte cache disabled.<br>2078 + bus wait states with load and lock 1Kbyte;<br>1103 + bus wait states with load and lock 512 bytes. |
| Reinitialize                | 03H          | 243 + bus wait states   |
| Load Control Register Group | 04H          | 42 + bus wait states  |

**A.2.7 Coding Optimizations**

Embedded applications often benefit from hand-optimized interrupt handlers and critical primitives. This section reviews coding optimizations which arise due to the microarchitecture of the i960 Cx instruction set processor. The examples in this section are constructed to illustrate particular optimization tricks. In general, every example could be further optimized by applying several techniques instead of one.



**A.2.7.1 Loads and Stores**

Separate load instructions from instructions that use load data. Remember that store instructions can also be reordered. Although it returns no results to a register, a poorly placed store in front of a critical load slows down the load. Reorder to issue the load first. Example A-1 shows a simple change that saved one clock from a five-clock loop.

**Example A-1. Overlapping Loads (Checksum)**

```

loop:                                opt_loop:
  ldob      (g0), g1                  ldob      (g0), g1
  addo      g1, g2, g2                cmpinco   g0, g3, g0
  cmpinco   g0, g3, g0                addo      g1, g2, g2
  bl.t      loop                      bl.t      opt_loop
Execution:                               Execution:
    
```

| Clock | REGop   | MEMop | CTRLop |
|-------|---------|-------|--------|
| 1     |         | ldob  |        |
| 2     |         | :     |        |
| 3     |         | :     |        |
| 4     | addo    |       | bl.t   |
| 5     | cmpinco |       | :      |
| 6     |         | ldob  |        |

| Clock | REGop   | MEMop | CTRLop |
|-------|---------|-------|--------|
| 1     |         | ldob  |        |
| 2     | cmpinco | :     |        |
| 3     |         | :     | bl.t   |
| 4     | addo    |       | :      |
| 5     |         | ldob  |        |



### A.2.7.2 Multiplication and Division

Begin multiply and divide instructions several cycles before instructions that use their results. MDU instructions consume less than one clock if they are sufficiently separated from the instructions that use their results. Also remember to use shift instructions to replace multiplication and division by powers of two. Example A-2 shows overlapping pointer math and a comparison with the 32x32 multiply time in a simple multiply-accumulate loop.

**Example A-2. Overlapping MDU Operations (Multiply-Accumulate)**

```

loop:
  ld      (g0), g2
  ld      (g1), g3
  muli    g2, g3, g4
  addi    g4, g5, g5
  addo    4, g0, g0
  addo    4, g1, g1
  cmpobl.t g0, g6, loop

opt_loop:
  ld      (g0), g2
  ld      (g1), g3
  muli    g2, g3, g4
  addo    4, g0, g0
  cmpo    g0, g6
  addo    4, g1, g1
  addi    g4, g5, g5
  bl.t    opt_loop
  
```

Execution (from DR):

| Clock | REGop | MEMop | CTRLop |
|-------|-------|-------|--------|
| 1     |       | ld    |        |
| 2     |       | ld    |        |
| 3     | muli  |       |        |
| 4     | :     |       |        |
| 5     | :     |       |        |
| 6     | :     |       |        |
| 7     | :     |       |        |
| 8     | addi  |       |        |
| 9     | addo  |       |        |
| 10    | addo  |       | bl.t   |
| 11    | cmpo  |       | :      |
| 12    |       | ld    |        |

Execution (from DR):

| Clock | REGop  | MEMop | CTRLop |
|-------|--------|-------|--------|
| 1     |        | ld    |        |
| 2     |        | ld    |        |
| 3     | muli   |       |        |
| 4     | : addo |       |        |
| 5     | : cmpo |       |        |
| 6     | : addo |       |        |
| 7     | :      |       | bl.t   |
| 8     | addi   |       | :      |
| 9     |        | ld    |        |



### A.2.7.3 Advancing Comparisons

Where possible, instructions which change condition codes should be separated from instructions that use condition codes. Although correct branch prediction gives the same performance as separating the compare from the branch, prediction is statistical while separation is deterministic. In the previous example, optimized code advanced the comparison enough that branch prediction is not being relied upon to keep the branch-true path executing at nine clocks. Furthermore, the branch-false path does not take extra clocks since the condition codes are known when the branch is encountered.

In a situation where the comparison and a branch cannot be separated to achieve a performance advantage, use the combined compare and branch instructions. This is likely to lead to faster execution since the two instructions are encoded in a single word. This code economy frees another location in the cache and the IS may be able to see the branch earlier because the branch is encoded in the same opcode word.

### A.2.7.4 Unrolling Loops

Expand small loops into larger loops which fill the cache, use more registers and pipeline their memory operations. The strategy is to begin accessing the memory system as soon as the routine is entered and to make the best use of the bus. Less bus bandwidth is used for the same operations if the algorithm is implemented with quad loads and/or stores.

The large register set allows an unrolled loop to have multiple sets of working temporary registers for operations in various stages. For example, the previous checksum example is repeated in Example A-3. The loop is unrolled to perform checksums nearly twice as fast as the simple loop.





**Example A-3. Unrolling Loops (Checksum)**

```

-- initialize --
loop:
  ldob      (g0), g1
  addo     g1, g2, g2
  cmpinco  g0, g3, g0
  bl.t     loop
  ret

-- initialize --
opt_loop:
  ldob      (g0), g1
  cmpinco  g0, g3, g0
  addo     g4, g2, g2
  bge.f    exit1
  ldob     (g0), g4
  cmpinco  g0, g3, g0
  addo     g1, g2, g2
  bl.t     opt_loop
exit2:
  addo     g4, g2, g2
  ret
exit1:
  addo     g1, g2, g2
  ret

```

Execution:

| Clock | REGop   | MEMop | CTRLop |
|-------|---------|-------|--------|
| 1     |         | ldob  |        |
| 2     |         | :     |        |
| 3     |         | :     |        |
| 4     | addo    |       | bl.t   |
| 5     | cmpinco |       | :      |
| 6     |         | ldob  |        |

Execution:

| Clock | REGop   | MEMop   | CTRLop |
|-------|---------|---------|--------|
| 1     |         | ldob g1 |        |
| 2     | cmpinco | :       | bge.f  |
| 3     | addo g4 | :       | :      |
| 4     |         | ldob g4 |        |
| 5     | cmpinco | :       | bl.t   |
| 6     | addo g1 | :       | :      |
| 7     |         | ldob g1 |        |





**A.2.7.5 Enabling Constant Parallel Issue**

As described in section A.2.1, “Parallel Issue” (pg. A-14), certain sequences of machine-type instructions can be executed in parallel, such as REG-MEM, REG-MEM-CTRL, MEM-CTRL. In Example A-4 the checksum loop is repeated. Another clock is eliminated by reordering code for parallel issue.

**Example A-4. Order for Parallelism (Checksum)**

```

-- initialize --
loop:
  ldob      (g0), g1
  addo      g1, g2, g2
  cmpinco   g0, g3, g0
  bl.t      loop
  ret

-- initialize --
opt_loop:
  addo      g4, g2, g2
  ldob      (g0), g1
  cmpinco   g0, g3, g0
  bge.f     exit1
  ldob      (g0), g4
  cmpinco   g0, g3, g0
  addo      g1, g2, g2
  bl.t      opt_loop
exit2:
  addo      g4, g2, g2
  ret
exit1:
  addo      g1, g2, g2
  ret
    
```

Execution:

| Clock | REGop   | MEMop | CTRLop |
|-------|---------|-------|--------|
| 1     |         | ldob  |        |
| 2     |         | :     |        |
| 3     |         | :     |        |
| 4     | addo    |       | bl.t   |
| 5     | cmpinco |       | :      |
| 6     |         | ldob  |        |

Execution:

| Clock | REGop   | MEMop   | CTRLop |
|-------|---------|---------|--------|
| 1     | addo g4 | ldob g1 | bge.f  |
| 2     | cmpinco | :       | :      |
| 3     |         | ldob g4 |        |
| 4     | cmpinco | :       | bl.t   |
| 5     | addo g1 | :       | :      |
| 6     | addo g4 | ldob g1 |        |



**A.2.7.6 Alternating from Side to Side**

The i960 Cx processor can sustain execution of two instructions per clock. To maximize this capability, try to start instructions in two of the three pipelines each clock. To increase parallelism, move an instruction from a unit which has become a critical path to a unit with available clocks. The AGU performs shifts, additions and moves that can replace EU operations. Literal addressing mode, in combination with EU or AGU operations, provides some freedom in deciding which side loads constants into registers. Remember to use addressing modes that the AGU executes directly (machine type M, not  $\mu$ ).

Table A-20 lists several conversions that can move an instruction to the AGU from either the EU or MDU. Example A-5 exploits the **lda** instruction to increase a 3x3 lowpass filter's performance by approximately 30 percent.

**Table A-20. Creative Uses for the lda Instruction**

| Operation  | Equivalent lda instruction      |
|--|---------------------------------|
| <code>addo 5, g0, g1 # constant addition</code>                                    | <code>lda 5(g0), g1</code>      |
| <code>shlo 2, g1, g2 # shifts by a constant</code>                                 | <code>lda [ g1 * 4], g2</code>  |
| <code>mov 31, g0 # constant load</code>  | <code>lda 31, g0</code>         |
| <code>shlo 2, g1, g2 # shift/add combination</code><br><code>addo 5, g2, g2</code> | <code>lda 5[ g1 * 4], g2</code> |
| <code>mov g0, g1 # register move</code>  | <code>lda (g0), g1</code>       |



**Example A-5. Change the Type of Instruction Used (3x3 Lowpass Mask)**

$$Y[] = X[] * M[]$$

$$M[] = \begin{bmatrix} \frac{1}{16} & \frac{2}{16} & \frac{1}{16} \\ \frac{2}{16} & \frac{4}{16} & \frac{2}{16} \\ \frac{1}{16} & \frac{2}{16} & \frac{1}{16} \end{bmatrix}$$

```

# initial values
# g0 points to X(0,0)
# g1 points to Y(1,1)
# g2 contains imax
# r4 load temp
# r5 accumulator
# r6 = imax (i count temp)
# r7 = jmax (j count temp)
# r8 = imax-1
# (new mask row offset)
# r9 = 2*imax - 2
# (new i offset)
# r10 is 2*imax + 1
# (new j offset)
b next_j
next_i:
    subo    r9, g0, g0
next_j:
# first mask row
    ldob   (g0), r5
    addo   1, g0, g0
    ldob   (g0), r4
    addo   1, g0, g0
    shlo   1, r4, r4
    addo   r4, r5, r5
    ldob   (g0), r4
    addo   r4, r5, r5
    addo   r8, g0, g0
# second mask row
    ldob   (g0), r4

# initial values
# g0 points to X(0,0)
# g1 points to Y(1,0)
# g2 contains imax
# r4 load temp
# r5 accumulator
# r6 = imax (i count temp)
# r7 = jmax (j count temp)
# r8 = imax-1
# (new mask row offset)
# r9 = 2*imax - 2
# (new i offset)
# r10 is 2*imax + 1
# (new j offset)
new_next_i:
new_next_j:
# first mask row
    addo   1, g1, g1
    ldob   (g0), r5
    addo   1, g0, g0
    ldob   (g0), r4
    addo   1, g0, g0
    lda    [r4 * 2], r4
    addo   r4, r5, r5
    ldob   (g0), r4
    addo   r4, r5, r5
    addo   r8, g0, g0
# second mask row
    ldob   (g0), r4

```

```

    addo    1, g0, g0
    shlo   1, r4, r4
    addo   r4, r5, r5
ldob    (g0), r4
    addo   1, g0, g0
    shlo   2, r4, r4
    addo   r4, r5, r5
ldob    (g0), r4
    shlo   1, r4, r4
    addo   r4, r5, r5
    addo   r8, g0, g0
# third mask row
ldob    (g0), r4
    addo   1, g0, g0
    addo   r4, r5, r5
ldob    (g0), r4
    addo   1, g0, g0
    shlo   1, r4, r4
    addo   r4, r5, r5
ldob    (g0), r4
    addo   r4, r5, r5
    shro   4, r5, r5
    stob   r5, (g1)
    addo   1, g1, g1

# update pointers
    cmpdeco 2, r6, r6
    bg     next_i
    mov    g2, r6
    cmpdeco 2, r7, r7
    subo   r10, g0, g0
    addo   2, g1, g1
    bg     next_j
    ret

    addo   1, g0, g0
    addo   r4, r5, r5
    lda    [r4 * 2], r4
ldob    (g0), r4
    addo   1, g0, g0
    lda    [r4 * 4], r4
    addo   r4, r5, r5
ldob    (g0), r4
    addo   r8, g0, g0
    lda    [r4 * 2], r4
    addo   r4, r5, r5

# third mask row
ldob    (g0), r4
    addo   1, g0, g0
    addo   r4, r5, r5
ldob    (g0), r4
    addo   1, g0, g0
    lda    [r4 * 2], r4
    addo   r4, r5, r5
ldob    (g0), r4
    addo   r4, r5, r5
    shro   4, r5, r5
    cmpdeco 2, r6, r6
    stob   r5, (g1)
    subo   r9, g0, g0

# update pointers
    bg.t   new_next_i
    addo   r9, g0, g0
    lda    (g2), r6
    cmpdeco 2, r7, r7
    lda    2(g1), g1
    subo   r10, g0, g0
    bg.t   new_next_j
    ret

```

Execution from DR (new loop):      Execution from DR (loop):

| Clock | REGop | MEMop | CTRLop |
|-------|-------|-------|--------|
| 1     | subo  |       |        |
| 2     |       | ldob  |        |
| 3     | addo  |       |        |
| 4     |       | ldob  |        |
| 5     | addo  |       |        |

| Clock | REGop | MEMop | CTRLop |
|-------|-------|-------|--------|
| 1     | addo  | ldob  |        |
| 2     | addo  |       |        |
| 3     |       | ldob  |        |
| 4     | addo  | lda   |        |
| 5     | addo  | ldob  |        |





| Clock | REGop   | MEMop | CTRLop |
|-------|---------|-------|--------|
| 6     | shlo    |       |        |
| 7     | addo    |       |        |
| 8     |         | ldob  |        |
| 9     | addo    |       |        |
| 10    | addo    |       |        |
| 11    |         | ldob  |        |
| 12    | addo    |       |        |
| 13    | shlo    |       |        |
| 14    | addo    |       |        |
| 15    |         | ldob  |        |
| 16    | addo    |       |        |
| 17    | shlo    |       |        |
| 18    | addo    |       |        |
| 19    |         | ldob  |        |
| 20    | shlo    |       |        |
| 21    | addo    |       |        |
| 22    | addo    |       |        |
| 23    |         | ldob  |        |
| 24    | addo    |       |        |
| 25    | addo    |       |        |
| 26    |         | ldob  |        |
| 27    | addo    |       |        |
| 28    | shlo    |       |        |
| 29    | addo    |       |        |
| 30    |         | ldob  |        |
| 31    | addo    |       |        |
| 32    | shro    |       |        |
| 33    |         | stob  |        |
| 34    | addo    |       | bg.t   |
| 35    | cmpdeco |       | :      |
| 36    | subo    |       |        |

| Clock | REGop   | MEMop | CTRLop |
|-------|---------|-------|--------|
| 6     | addo    |       |        |
| 7     | addo    | ldob  |        |
| 8     | addo    | lda   |        |
| 9     | addo    | ldob  |        |
| 10    | addo    | lda   |        |
| 11    | addo    | ldob  |        |
| 12    | addo    | lda   |        |
| 13    | addo    | ldob  |        |
| 14    | addo    |       |        |
| 15    | addo    | ldob  |        |
| 16    | addo    | lda   |        |
| 17    | addo    | ldob  |        |
| 18    | addo    |       |        |
| 19    | shro    |       |        |
| 20    | cmpdeco | stob  | bg.t   |
| 21    | subo    |       | :      |
| 22    | addo    | ldob  |        |



### A.2.7.7 Branch Prediction

Conditional branches execute faster if the branch direction is correctly predicted using the branch prediction bits on conditional instructions. This is particularly true when a comparison cannot be separated from the test in a conditional instruction. When the prediction is correct, branches generally execute in parallel with other execution. If prediction is not correct, the worst case branch time for cached execution is still two clocks.

Although prediction bits are most likely set to gain maximum throughput, different strategies can be used for setting the prediction bits. A code sequence dominated by comparisons and conditional branches might see large differences between execution time of the fastest path and slowest path. Prediction bits can be set to provide the best average throughput to ensure the fastest worst case execution or to minimize deviation between slowest and fastest times.

### A.2.7.8 Branch Target Alignment

Branch target code executes with more parallelism in the first clock if the branch target is long-word or quad-word aligned. Quad-word alignment is preferable for prefetch efficiency.

The IS sees four words in a clock when the requested IP is long-word aligned and three words when the requested IP is not on a long-word boundary. Aligned branch targets give the scheduler another word to examine on the first clock following a branch. However, there are only a few cases where this optimization pays off.

The IS takes advantage of seeing four words on the first clock after a branch when the fourth word is a branch or micro-flow and all three previous opcodes are executable in one clock. Example A-6 shows a three-word executable group (**add** followed by **lda** with 32-bit constant) followed by a micro-flow. The sequence executes one clock faster when the branch target is long-word aligned. The reason for the extra clock is described in section A.2.6, “Micro-flow Execution” (pg. A-36). Since optimization can save one clock under such circumstances, it could be worthwhile in small, frequently executed loops.



**Example A-6. Align Branch Targets**

```

-- initialize --
.align 2
mov g0, g0    #nop
target:
  add    g0, g1
  lda    0xffffffff, g2
  scanbit g3, g4
  addo   g5, g6
- more -

-- initialize --
.align 2
target:
  add    g0, g1
  lda    0xffffffff, g2
  scanbit g3, g4
  addo   g5, g6
- more -
    
```

Execution:

Execution:

| Clock | REGop   | MEMop | CTRLop   | Clock | REGop   | MEMop | CTRLop   |
|-------|---------|-------|----------|-------|---------|-------|----------|
| 1     |         |       | b target | 1     |         |       | b target |
| 2     |         |       | :        | 2     |         |       | :        |
| 3     | addo    | lda   |          | 3     | addo    | lda   |          |
| μ 4   | scanbit |       |          | μ 4   | scanbit |       |          |
| μ 5   | :       |       |          | 5     | addo    |       |          |
| 6     | addo    |       |          | 6     | more    |       |          |
| 7     | more    |       |          |       |         |       |          |

**A.2.7.9 Replacing Straight-Line Code and Calls**

**bal** takes three or four clocks to execute and does not cause a frame spill to memory. Replacing **calls** with branch and link instructions is an obvious optimization. However, a not-so-obvious but equally beneficial optimization is to use branches and **bal** to reduce a critical procedure’s code size.

When porting optimized algorithms originally written for other processors, the software engineer often expands the code in a straight-line fashion due to branch speed penalties of the original target and the lack of on-chip caching. On the i960 Cx processors, branches are virtually free in cached programs and cached program execution is dramatically faster than non-cached execution. Therefore, branches and the branch-and-link instruction should be used to compress algorithms into the cache. For example, the previous low-pass filter routine could be modified to use coefficients from registers instead of literals. A short code piece could then sequence different filter coefficients through the registers and branch (using **bal**) to the filter loop. The entire routine would fit in the instruction cache and could perform a chain of linear filters without a procedure call.





## A.2.8 Utilizing On-chip Storage

The processor has the ability to consume instructions and execute quad-word memory operations in parallel with arithmetic operations every clock. The instruction cache, data cache (i960 CF processor only), register cache and on-chip data RAM are valuable resources for sustaining such optimized execution.

Compiler experimentation is an important aid to maximize utilization of on-chip storage resources. Compiler optimization is not limited to instruction caching. In particular, execution profiling will automate assignment of frequently used data to the data RAM. Availability of data RAM provides more options for partitioning data between context-based storage (register cache), general storage (data cache where available) and static caching (data RAM).

### A.2.8.1 Instruction Cache

If an algorithm fits into the instruction cache, it generally executes faster than if it did not fit. This is true even if the compressed code contains more comparisons and branches than uncompressed code contains.

If a loop fits in the cache but is not capable of executing two instructions per clock due to memory or resource dependencies, keep unrolling the loop and pipelining operations until the cache is full. To increase performance of loops with multiple iterations and memory operations, unroll the loops until all registers are used or the cache is full.

If the system is interrupt-intensive, consider locking interrupt service routines into the cache. On the i960 CF microprocessor, cache locking is extended to any frequently executed code segments. Some experimentation may be necessary to determine if cache locking impacts performance of remaining non-locked code.

Finally, as mentioned in a previous section on branches, aligning branch targets can improve performance. While long-word aligned branch targets improve the scheduler's lookahead ability in the first clock of the branch, quad-word aligned branch targets reduce the number of long-word instruction fetches issued. Although the long-word fetch is implemented to reduce cache miss latency for many cases, the quad-word instruction fetch is more efficient for system throughput.

### A.2.8.2 Data Cache (i960 CF Processor Only)

The i960 CF microprocessor has a 1 Kbyte, direct-mapped data cache. The effect of data caching on performance is usually not as great as the effect of instruction caching because the processor often accesses data in a random, occasional pattern compared to the repetitive, looping pattern commonly seen with instruction execution.

**A**

The data cache behaves like SRAM for cache hits, delivering data in a single clock. Data cache misses require BCU interaction, as do all stores to external memory addresses. Data caching can be enabled for particular memory regions. In most cases, programmers will use this function only to distinguish non-cacheable memory-mapped I/O space from ordinary data memory. Once the data cache is enabled, its operation is transparent as there are no further programming options.

### A.2.8.3 Register Cache

Register cache can be thought of as a data cache which selectively caches only that data related to procedure context. section 5.2, “CALL AND RETURN MECHANISM” (pg. 5-2) describes the i960 Cx processors’ register cache.

The register cache/data RAM partition is programmable. Therefore, the user can determine the trade-off between procedural context caching and static caching of procedure variables in the on-chip data RAM. Experiments can be run to measure the sensitivity of system performance to register cache depth of a fixed program. Minimizing register cache depth maximizes on-chip data RAM for variable caching.

Some situations exist where **flushreg** can optimize register cache usage. When an application crosses the boundary between non-real-time processing and real-time processing, it might be desirable to flush the register set. Flushing the register set at the beginning of a routine saves time that would otherwise be spent on frame spills later in the routine. However, this approach may actually result in a greater number of spills occurring than would otherwise have occurred without the premature flush.

This technique may be used to control interrupt latency within sections of background code. For example, it may be advantageous to execute a flush at the beginning of a routine which executes many loads from very slow memory. This reduces interrupt latency within that code section since there is no possibility of the interrupt’s frame spill being impeded by slow memory operations.

### A.2.8.4 Data RAM

On every clock, 128 bits of data can be loaded from or stored to the data RAM. This rate is sustained simultaneously with single-clock arithmetic operations executing from the independent REG-side register ports.

Allocated correctly, this resource dramatically increases performance of critical application algorithms. If data RAM space is scarce, locations can be dynamically allocated. If data RAM space is plentiful, locations can be globally allocated to achieve minimum latency to critical variables.



Variables which are used heavily over short periods of time or are used heavily by one procedure should be dynamically allocated. Such variables could be DMA descriptors for the currently active packets or coefficients for filters which process large images on command. Dynamically allocated data RAM space would be loaded from main memory at the onset of intense processing and restored to main memory as the activity subsides.

Global allocation of DR space should be saved for storing variables which are heavily used by a variety of procedures over a long period of time or for storing variables needed by latency-critical activities. For example, the programmer may wish to allocate space for coefficients of a continuously operating filter or standard DMA descriptor templates from which run-time descriptors are built in data RAM.

**A.2.9 Summary**

Table A-21 summarizes code optimization tactics presented in the previous sections. Optimizing compilers for the i960 processor family are designed to exploit most of these techniques. Advanced compilers also incorporate profiling features to automate much of the experimentation process.

**Table A-21. Code Optimization Summary**

| Tactic                    | Description   |
|---------------------------|---|
| Advance "long" operations | Separate comparisons, loads, stores and MDU operations from the instructions that use their results.  |
| Unroll loops              | Unroll time-consuming loops until:<br>1) processor executes loop with two instructions per clock;<br>2) bus is saturated with quad operations;<br>3) no registers are left;<br>4) loop does not fit in the cache. |
| Order for parallelism     | Alternate REG-side instructions with MEM-side instructions so they may be issued in parallel.   |
| Migrate the operation     | To enable parallelism, move EU and MDU operations to the AGU or vice versa.   |
| Use branch prediction     | Set prediction bits correctly in conditional instructions.  |
| Align branch targets      | Align branch targets of critical loops on an even-word or quad-word boundary.   |
| Compress code to fit      | If loop does not fit in cache, use branches, branch-and-links or calls to compress code size so it fits. Use code size optimization instructions (e.g., <b>cmpobe</b> ) where possible.                           |
| Use data RAM              | Use high-bandwidth data RAM space for performance-critical and/or latency-critical variables  |







B

## BUS INTERFACE EXAMPLES

I



## APPENDIX B BUS INTERFACE EXAMPLES

This appendix describes how to interface the processor to external memory systems. Also discussed are non-pipelined and pipelined burst SRAM, non-pipelined burst DRAM, slow 8-bit memory systems and high performance pipelined burst EPROM. All issues discussed in each example are independent of operating frequency.

Design examples, state machines and pseudo-code are for example only; refer to the *EP80960Cx Evaluation Platform User's Guide* (order number 272456) for actual programmable logic equations.

### B.1 NON-PIPELINED BURST SRAM INTERFACE

This appendix uses a simple SRAM design to demonstrate how the bus and control signals are used. The design also demonstrates the internal wait state generator. The basic SRAM interface provides the basic information needed to design most I/O and memory interfaces. The design supports burst and non-burst bus accesses. The SRAM interface is important for shared memory systems; variations can be used to communicate with external memory mapped peripherals.

#### B.1.1 Background

SRAM devices are available in a wide variety of packages and densities. SRAM address pins are always dedicated as inputs. Data pins may be configured in two ways:

- each pin can be dedicated as an input or an output
- a set of data pins may be used for both data in and data out

Control signals usually found on SRAM include: Chip Enable ( $\overline{CE}$ ), Output Enable ( $\overline{OE}$ ) and Write Enable ( $\overline{WE}$ ). The following example deals with a SRAM that has  $\overline{CE}$ ,  $\overline{OE}$  and  $\overline{WE}$  control signals, address inputs and data input/output pins.

Memory is read when  $\overline{CE}$  and  $\overline{OE}$  are asserted and  $\overline{WE}$  is not asserted. Memory is written when  $\overline{CE}$  and  $\overline{WE}$  are asserted. The  $\overline{OE}$  input becomes don't care when  $\overline{WE}$  is asserted. However, it is recommended that  $\overline{OE}$  is not asserted at the beginning or end of a write cycle; this can lead to bus contention.

#### B.1.2 Implementation

Figure B-1 illustrates a 32-bit burst access SRAM interface. The design may be simplified if burst access modes are not required; it is easily modified for 8- or 16-bit buses.

**B**

$\overline{\text{WAIT}}$  generated by the internal wait state generator, is used to generate write strobes at the proper place in the write cycle.  $\overline{\text{WAIT}}$  is used in the address generation circuit to generate mid-burst addresses. External address generation improves performance in burst accesses.

**B.1.3 Block Diagram**

The 32-bit burst SRAM interface consists of chip select logic, a state machine Programmable Logic Device (PLD) and write enable logic.

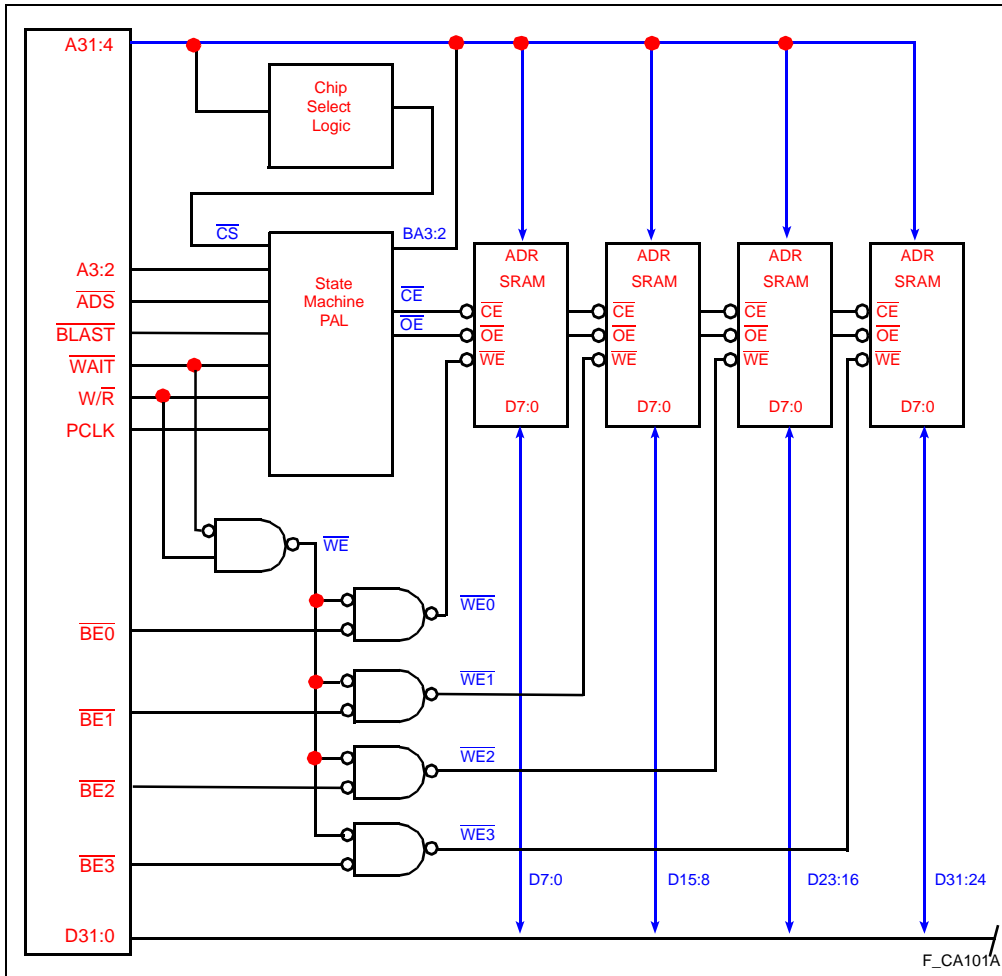


Figure B-1. Non-Pipelined Burst SRAM Interface



### B.1.3.1 Chip Select Logic

Chip select logic is a simple asynchronous data selector; it can be implemented with an external state machine or PLD. Chip select ( $\overline{CS}$ ) is based only on the address and is not qualified with any other signals. The state machine PLD qualifies  $\overline{CS}$  with  $\overline{ADS}$ . See section B.2.2, “Waveforms” (pg. B-13) for a more in-depth discussion of chip select generation.

### B.1.3.2 State Machine PLD

The SRAM state machine PLD generates the  $\overline{CE}$  and  $\overline{OE}$  signals to the SRAM. This PLD also contains the next-address generation logic; this logic improves burst access performance. The improvement occurs because the i960 Cx processors' worst-case address valid delay is longer than the PLD's worst-case delay.

### B.1.3.3 Write Enable Generation Logic

The write enable generation logic generates the  $\overline{WE}$  signal to the SRAM.  $\overline{WE}$  signals are conditioned on the i960 Cx processor byte enables ( $\overline{BE3:0}$ ), the write/read signal ( $W/\overline{R}$ ) and the wait signal ( $\overline{WAIT}$ ).

There is a write enable signal ( $\overline{WE3:0}$ ) for each byte position corresponding to the byte enable signals ( $\overline{BE3:0}$ ); this allows byte, short-word and word-wide writes. Read accesses to this memory system always result in word reads. The i960 Cx devices — in the case of byte- or short-word reads — read the data from the correct place on the data bus.

### B.1.3.4 Chip Select Generation

$\overline{ADS}$  assertion during the PCLK rising edge indicates the address is valid. Address setup time to this clock edge is PCLK period ( $T_{PP}$ ), minus address output delay ( $T_{OV}$ ).  $\overline{CS}$  signal generation time ( $\overline{CS}_{gen}$ ) must satisfy the input setup time of the State Machine PLD ( $T_{PLD\_setup}$ ). Therefore:

$$\overline{CS}_{gen} = T_{PP} - T_{OV} - T_{PLD\_setup} \quad \text{Equation B-1}$$

B.1.4 Waveforms

Figure B-2 shows a Non-Pipelined SRAM Read Waveform; Figure B-3 shows a Non-Pipelined SRAM Write Waveform.

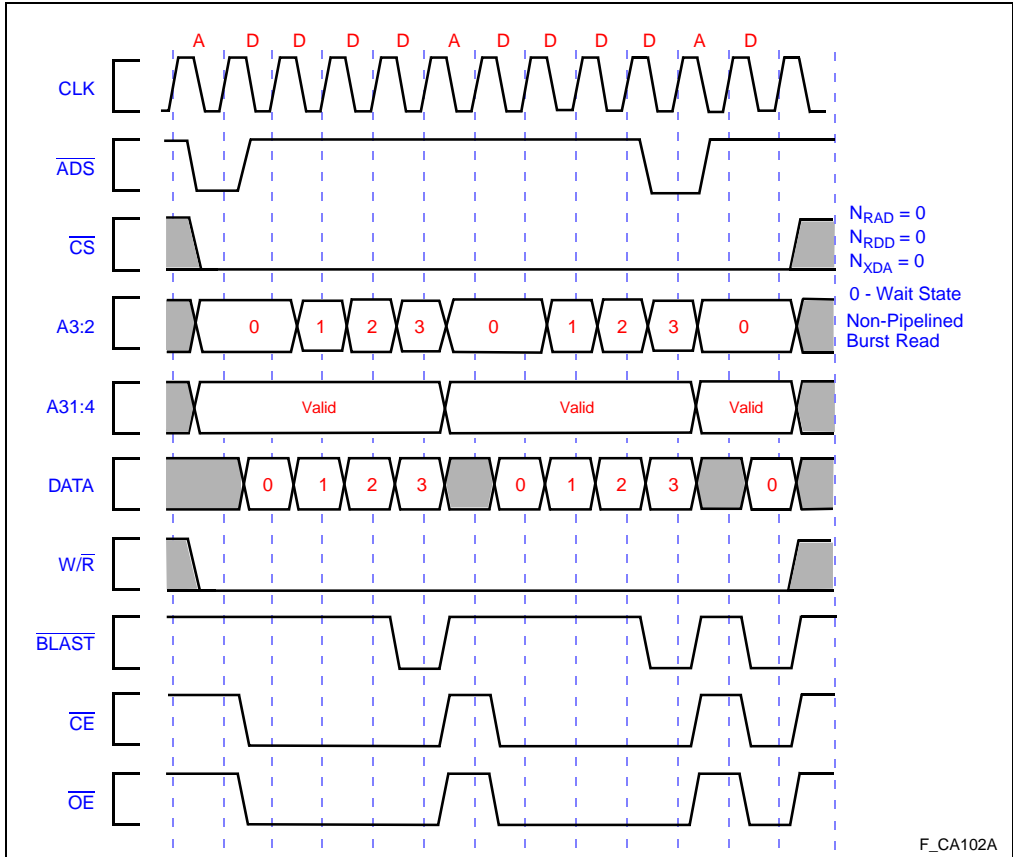


Figure B-2. Non-Pipelined SRAM Read Waveform

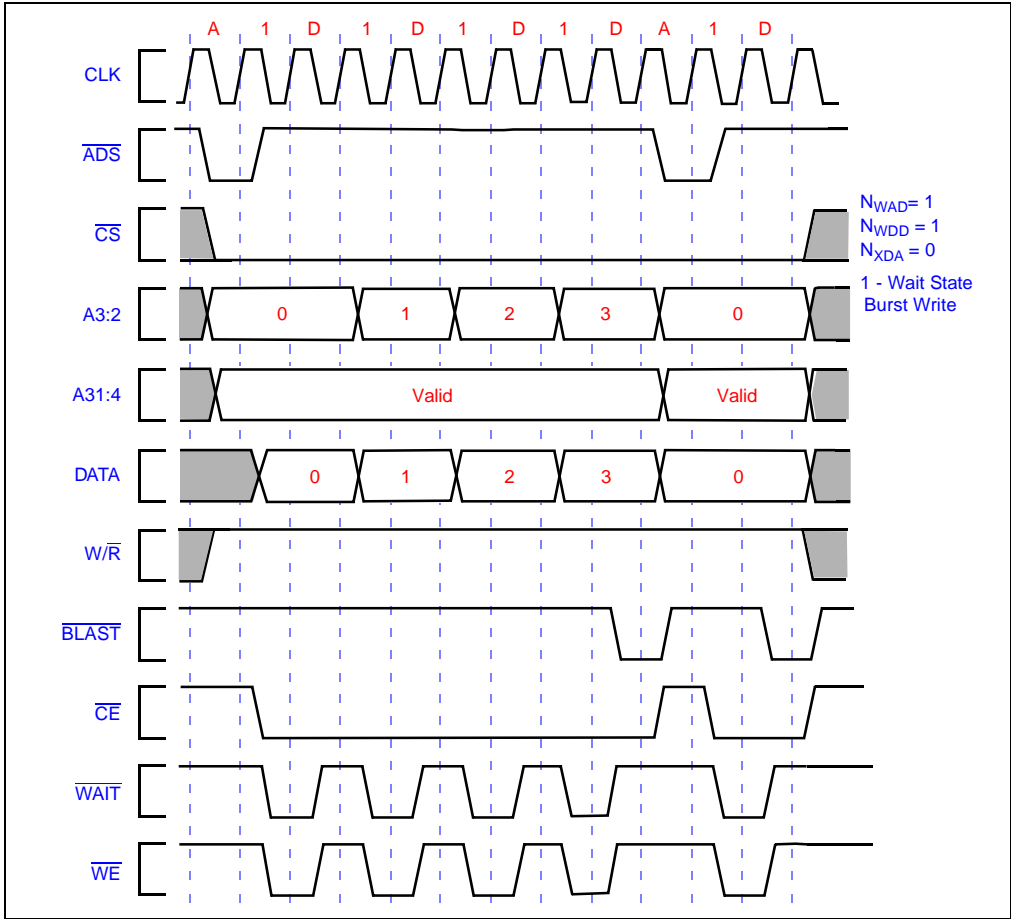


Figure B-3. Non-Pipelined SRAM Write Waveform

Errata (12-06-94 SRB)  
 ADS# clock incorrectly goes low in the sixth and eleventh cycles.  
 It now correctly goes low in the first and tenth cycles.

**B.1.4.1 Wait State Selection**

The i960 Cx processors incorporate an internal wait state generator; wait state selection is dictated by the memory system. The number of  $N_{RAD}$  wait states required is a function of output enable access time, chip enable access time or address access time.  $N_{RAD}$  must be selected so the wait states and data cycle accommodate the longest of these times. It is important to consider PLD output delay.



## BUS INTERFACE EXAMPLES

The number of  $N_{RDD}$  wait states required is a function of address access time.  $N_{RDD}$  must be selected so that the wait states and data cycle accommodate the memory system's address to data time. If the memory system is using the burst addresses provided by the i960 Cx processors, it is important to consider address output delay from the i960 Cx devices. If external address generation is used, PLD delay is important.

The number of  $N_{WAD}$  and  $N_{WDD}$  wait states required is a function of memory write cycle time. The number of  $N_{XDA}$  wait states required is a function of the memory system's output-to-float time.  $N_{XDA}$  determines how soon read data from the memory must be off the data bus before any other device asserts data on the data bus. This could be a read from another memory system or a write from the i960 Cx processors.

### B.1.4.2 Output Enable and Write Enable Logic

The output enable signal is simply (see Figure B-1):

$$\overline{OE} = W/\overline{R} \quad \text{Equation B-2}$$

The PLD is used to buffer the  $W/\overline{R}$  signal; this may be necessary to reduce the load on the  $W/\overline{R}$  signal.

The write enable signals are:

$$\overline{WE} = \overline{!(WAIT \& W/\overline{R})};$$

or

$$\overline{WE0} = \overline{!(WE \& BE0)};$$

$$\overline{WE1} = \overline{!(WE \& BE1)};$$

$$\overline{WE2} = \overline{!(WE \& BE2)};$$

$$\overline{WE3} = \overline{!(WE \& BE3)};$$

The  $\overline{WAIT}$  signal is used to create the write strobe. When  $W/\overline{R}$  indicates a write and  $\overline{BEx}$  and  $\overline{WAIT}$  are asserted, the logic asserts  $\overline{WE}$ . The i960 CA/CF Microprocessor Data Sheets guarantee a relationship from  $\overline{WAIT}$  high to write data invalid.

### B.1.4.3 State Machine Descriptions

The state machine PLD incorporates two state machines: one controls SRAM chip enable ( $\overline{CE}$ ); the other generates the A3:2 address signals for multiple word burst accesses.



The chip enable state machine (Figure B-4) controls the  $\overline{CE}$  signal.  $\overline{CE}$  is normally not enabled, but when both  $\overline{ADS}$  and  $\overline{BSRAM\_CS}$  are asserted,  $\overline{CE}$  is asserted and remains asserted until  $\overline{BLAST}$  is asserted.  $\overline{BLAST}$  indicates the access is complete.  $\overline{CE}$  is the output of the state register; therefore, the  $\overline{CE}$  output delay is the clock-to-output time of the PLD. Minimizing  $\overline{CE}$  delay provides more memory access time.

The A3:2 address generation state machine (Figure B-5) generates consecutive addresses for multiple word burst accesses. The address generation state machine is not necessary if the memory region is defined in the region configuration table as non-burst.

The burst address outputs (BA3:2) correspond to registers within the PLD. Address generation time then corresponds to the clock-to-output time of the PLD. The BA3:2 signals are forced to 0 when  $\overline{BLAST}$  is asserted.

The pseudo-code descriptions that follow the figures are provided only to describe the state machine diagrams. They are not intended to be PLD equations. A trailing # indicates a signal is asserted low.

In the pseudo-code description, the assertion of  $\overline{ADS}$  and  $\overline{SRAM\_CS}$  indicates the beginning of an access. The state machine jumps to the proper state based on A3:2. The assertion of  $\overline{CE}$  indicates that an access is underway. The assertion of  $\overline{CE}$ ,  $\overline{!WAIT}$  and  $\overline{!BLAST}$  indicates that the current transfer is complete and it is time to generate the next address. The assertion of  $\overline{BLAST}$  indicates the access is complete.

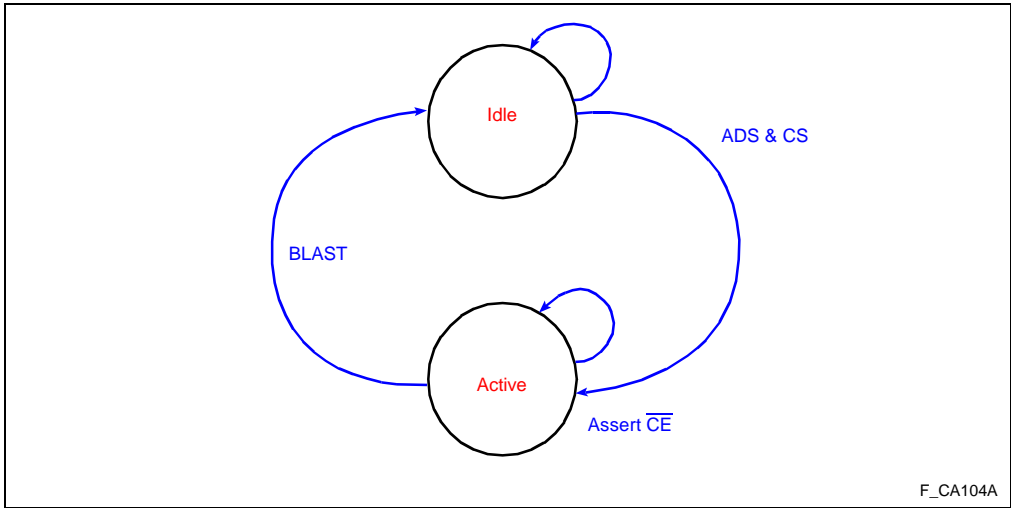


Figure B-4. Chip Enable State Machine



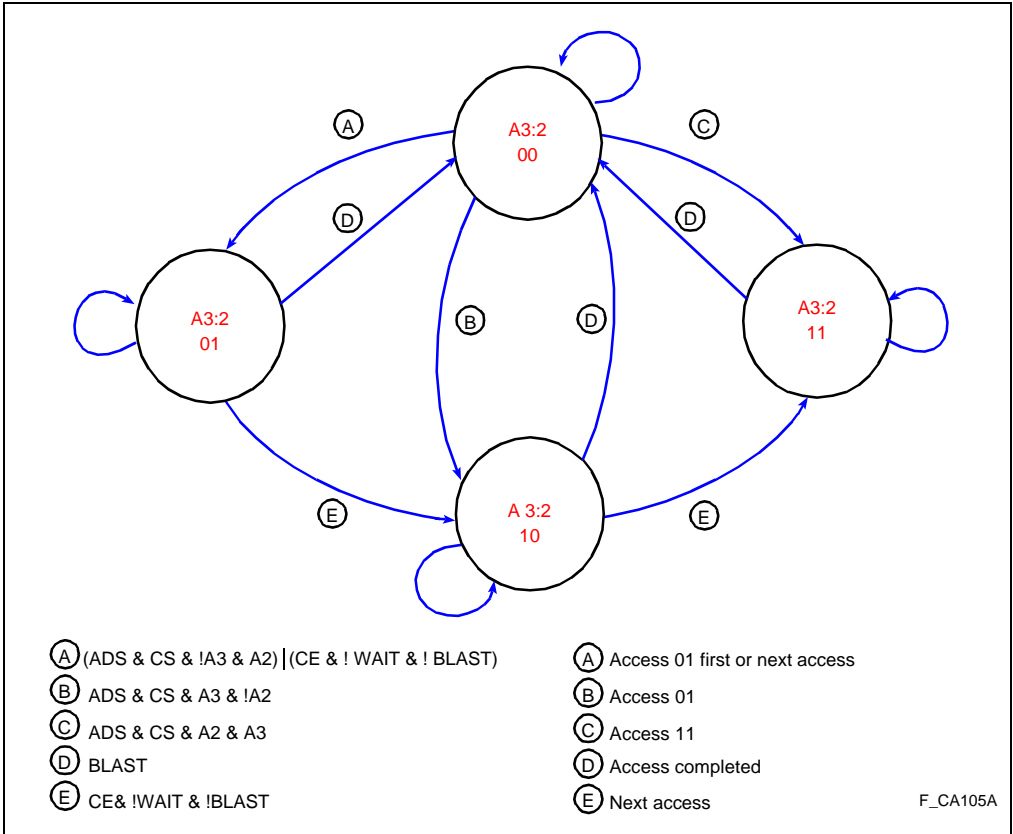


Figure B-5. A3:2 Address Generation State Machine

| Pseudo-code Key |                        |    |                    |
|-----------------|------------------------|----|--------------------|
| #               | signal is asserted low | == | equality test      |
| !               | logical NOT            | := | clocked assignment |
| &               | logical AND            | =  | value assignment   |
|                 | logical OR             | X  | Don't Care         |



```
STATE_0:                                     /* BA3:2 = 00 */
IF                                           /* access 01 OR Next access */
  (ADS && SRAM_CS && (A3:2 == 01))|(CE & !WAIT & !BLAST);
THEN
  next state is STATE_1;
ELSE IF                                     /* access 10 */
  ADS && SRAM_CS && (A3:2 == 10);
THEN
  next state is STATE_2;
ELSE IF                                     /* access 11 */
  ADS && SRAM_CS && (A3:2 == 11);
THEN
  next state is STATE_3;
ELSE                                       /* Idle or access 00 */
  next state is STATE_0;

STATE_1:                                     /* BA3:2 = 01 */
IF                                           /* Next access */
  CE & !WAIT & !BLAST;
THEN
  next state is STATE_2;
ELSE IF                                     /* Done */
  BLAST;
THEN
  next state is STATE_0;
ELSE                                       /* Just Wait */
  next state is STATE_1;

STATE_2:                                     /* BA3:2 = 10 */
IF                                           /* Next access */
  CE & !WAIT & !BLAST;
THEN
  next state is STATE_3;
ELSE IF                                     /* Done */
  BLAST;
THEN
  next state is STATE_0;
ELSE                                       /* Just Wait */
  next state is STATE_2;

STATE_3:                                     /* BA3:2 = 11 */
IF                                           /* Done */
  BLAST;
THEN
  next state is STATE_0;
ELSE
  next state is STATE_3;
```

### B.1.5 Trade-offs and Alternatives

The SRAM example just described demonstrates a burst SRAM memory interface. If a non-burst interface is desired, the address generation section of the state machine PLD may be removed. The design is also easily expanded to accommodate multiple banks of SRAM.

The i960 Cx processors' integrated bus controller simplifies external memory system design. The internal wait state generator decouples the memory speed from the memory controller. The memory control PLD does not use any of the memory access parameters. So, operation of the memory control PLD is independent of memory access times. Memory access parameters are entered into the memory region configuration table via software.

## B.2 PIPELINED SRAM READ INTERFACE

The following example illustrates the implementation of a pipelined read SRAM system. A zero wait state pipelined read memory system will have a 20 percent improvement in read data bandwidth over a non-pipelined memory system using the same memory devices. The pipelined read memory system is similar in design to the burst memory system.

A pipelined read memory system is the highest performance memory system that can be interfaced to the i960 Cx processors. The address cycle of consecutive accesses is overlapped with the data cycle of the previous access. This results in the maximum bandwidth utilization of the bus. (See Figure B-6.)

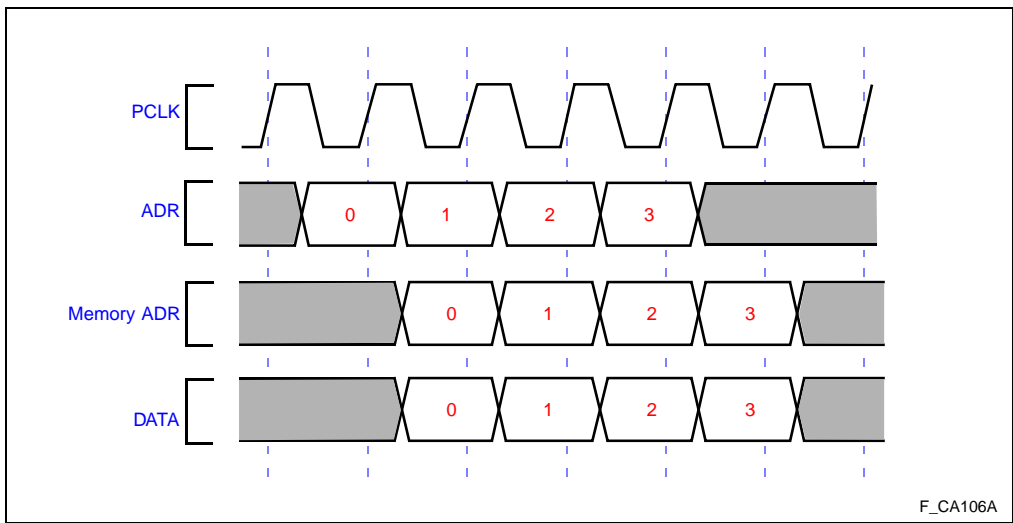


Figure B-6. Pipelined Read Address and Data



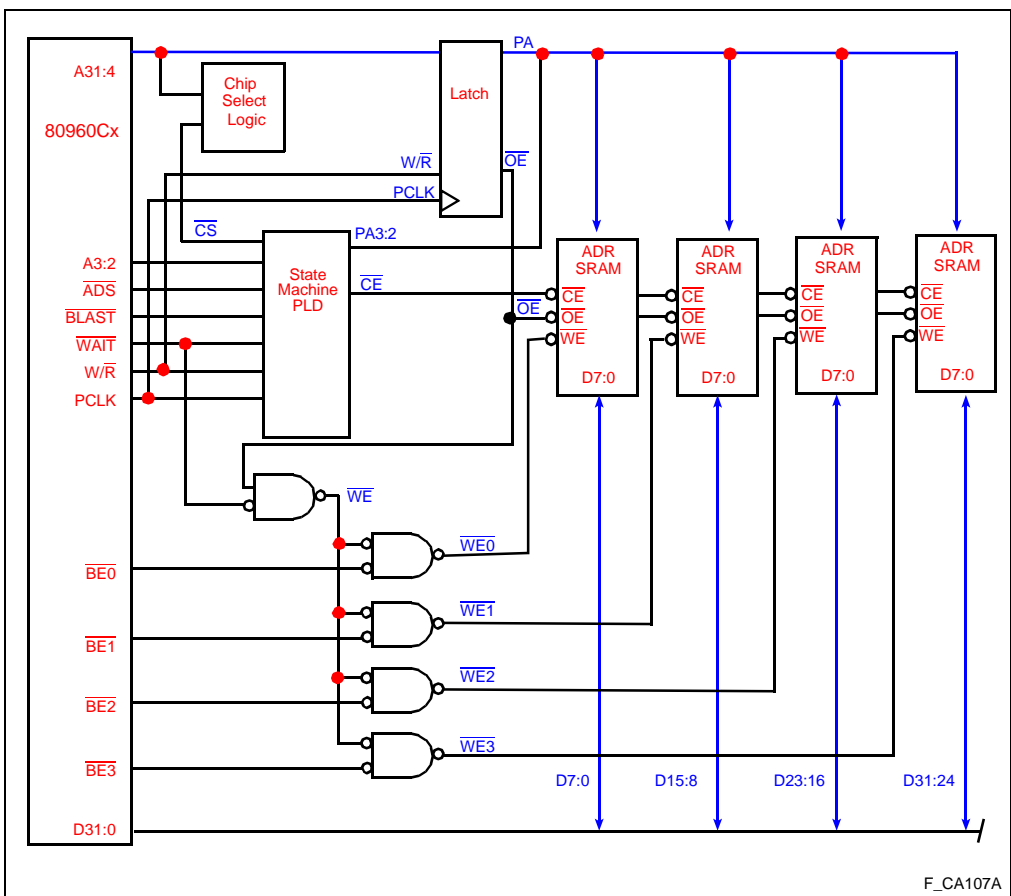


**B.2.1 Block Diagram**

The same SRAM used in a non-pipelined read memory system can be used in a pipelined read memory system. Figure B-7 shows a 32-bit-wide burst read pipelined memory system. Burst mode is used to speed write accesses.

The design of a pipelined read SRAM interface is very similar to the design of a non-pipelined SRAM interface. The difference is that an address latch and a  $W/\bar{R}$  latch have been added.

Chip select logic is a simple asynchronous data selector. Chip select ( $\bar{CS}$ ) is based only on the address and is not qualified with any other signals. See section B.1, “NON-PIPELINED BURST SRAM INTERFACE” (pg. B-1) for more information on chip select generation.



**B**

Figure B-7. Pipelined SRAM Interface Block Diagram

## BUS INTERFACE EXAMPLES

### B.2.1.1 Address Latch

During pipelined reads, the i960 Cx processors output the next address during the last data cycle of the current access. This requires either an address latch or memory devices that are designed to work with the pipelined bus.

### B.2.1.2 State Machine PLD

The state machine PLD contains logic to control  $\overline{CE}$  and address signals A3:2.  $\overline{CE}$  is controlled by a simple state machine; A3:2 automatically increment during burst accesses. The A3:2 signals are pipelined; they must be latched for read accesses. Write accesses are not pipelined; therefore it is necessary for burst writes to latch A3:2 on reads and pass A3:2 through. The A3:2 generation is implemented as a state machine to achieve minimum address delay out of the PLD. PA3:2 (pipelined address 3:2) outputs are also the state bit of the PLD. This ensures that the address delay is only the clock-to-output time for the PLD.

### B.2.1.3 Write Enable Logic

Write enable logic uses the byte enable signals ( $\overline{BE3:0}$ ), the  $\overline{WAIT}$  signal and a latched version of the  $W/\overline{R}$  signal ( $\overline{OE}$ ). Therefore:

$$\overline{WE} = !(\overline{OE} \& \overline{WAIT} \& \overline{BE});$$

or:

$$\overline{WE0} = \overline{OE} \mid \overline{WAIT} \mid \overline{BE0};$$

$$\overline{WE1} = \overline{OE} \mid \overline{WAIT} \mid \overline{BE1};$$

$$\overline{WE2} = \overline{OE} \mid \overline{WAIT} \mid \overline{BE2};$$

$$\overline{WE3} = \overline{OE} \mid \overline{WAIT} \mid \overline{BE3};$$

$\overline{DEN}$  remains asserted as long as consecutive pipelined read accesses continue.  $\overline{DEN}$  and  $DT/\overline{R}$  are related to the data, not the address; therefore,  $\overline{DEN}$  and  $DT/\overline{R}$  are not pipelined and retain the same timing for pipelined and non-pipelined reads.

In the pipelined read mode, a series of non-burst accesses results in  $\overline{ADS}$  remaining asserted for several clock cycles. Similarly,  $\overline{BLAST}$  remains asserted for several clock cycles.

$W/\overline{R}$  behaves slightly differently for pipelined reads than for non-pipelined reads.  $W/\overline{R}$  is not valid for the last cycle of a pipelined read. This requires that  $W/\overline{R}$  be latched for pipelined reads similar to A31:2. The following signals are pipelined during pipelined read accesses: A31:2,  $\overline{BE3:0}$ ,  $\overline{SUP}$ ,  $\overline{DMA}$  and  $D/\overline{C}$ . All of these pipelined signals are invalid during the last cycle of a pipelined read.

Address delay time for the pipelined read is the output valid time of the address latch (or the PA3:2 generation PLD). Minimizing address delay maximizes access time.



B.2.2 Waveforms

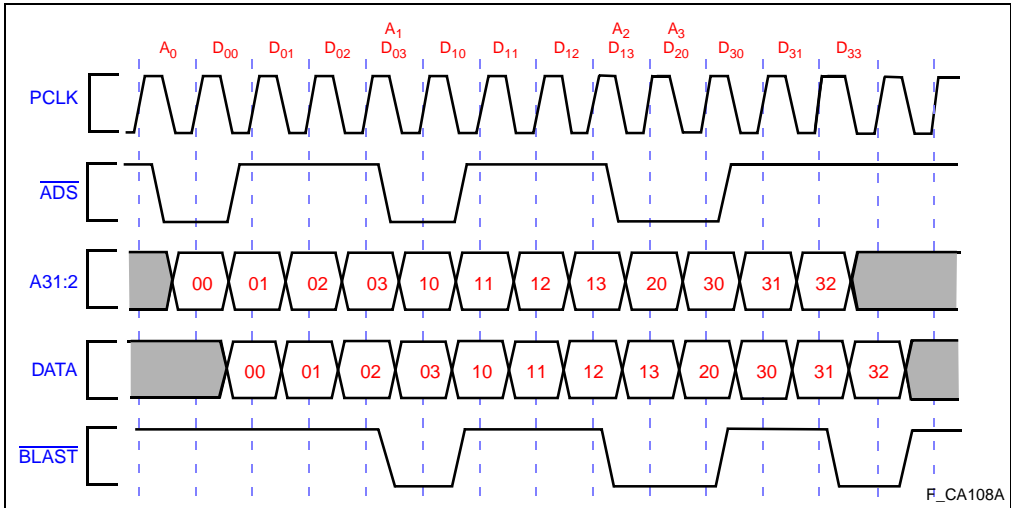


Figure B-8. Pipelined Read Waveform

B.2.2.1 State Machines

Chip enable ( $\overline{CE}$ ) is controlled by a simple state machine. The state machine is normally in the idle state and  $\overline{CE}$  is not asserted. When  $\overline{ADS}$  and  $\overline{PSRAM\_CS}$  are asserted, the  $\overline{CE}$  state machine goes to the active state.  $\overline{CE}$  remains active until  $\overline{BLAST}$  is asserted.

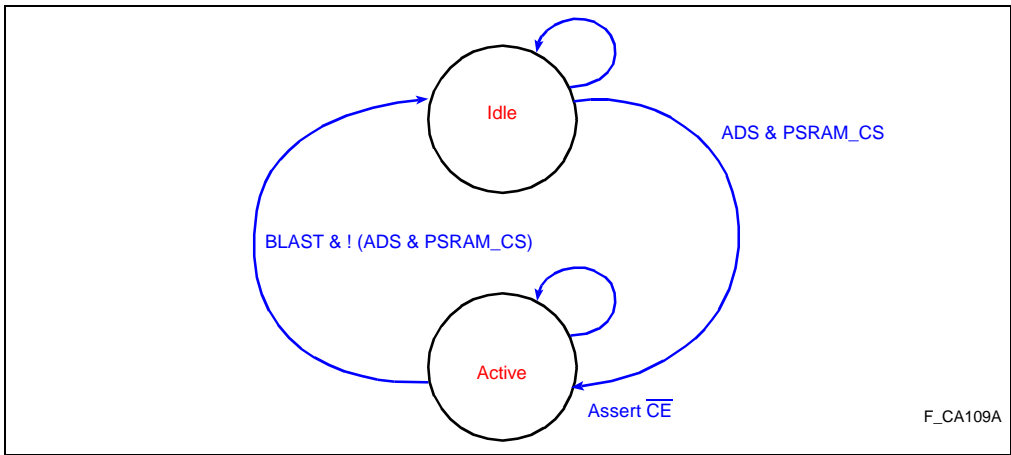


Figure B-9. Pipelined Read Chip Enable State Machine



The PA3:2 state machine latches the A3:2 address bits on read and generates the low address bit for writes. During read, PA3:2 is a latched version of A3:2. If a write access occurs, the state machine generates the proper PA3:2 addresses.

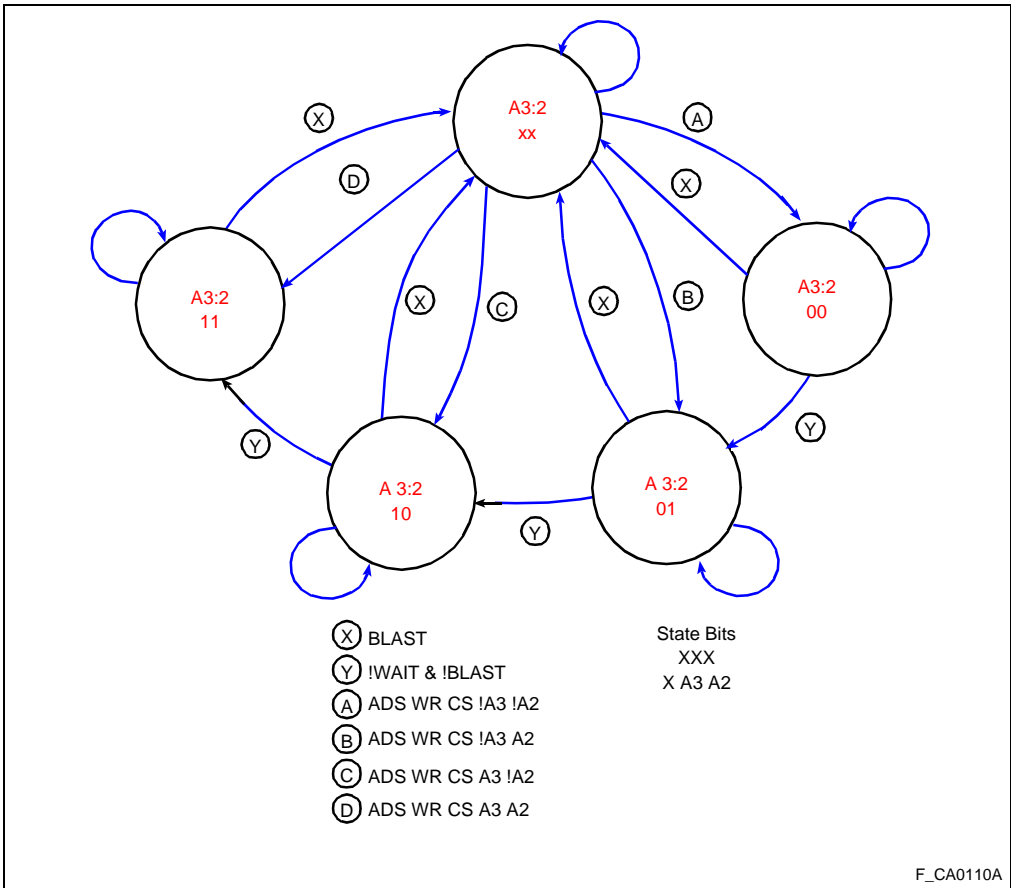


Figure B-10. Pipelined Read PA3:2 State Machine Diagram

In the READ\_STATE, the state machine simply latches A3:2 and outputs them as PA3:2. On a write, the state machine jumps to the appropriate state based on the value of A3:2. When in a write state, the state machine will advance to the next write state if  $\overline{\text{WAIT}}$  and  $\overline{\text{BLAST}}$  are not asserted. The state machine can advance from any write state to the READ\_STATE.



### B.2.3 Trade-offs and Alternatives

The example described above demonstrates a burst pipelined read SRAM memory interface. Burst mode is used to improve write performance. If write performance is not critical (i.e., if the region is used only for code), the next address generation PLD can be removed. The design is easily expanded to accommodate multiple SRAM banks.

## B.3 INTERFACING TO DYNAMIC RAM

This section provides an overview of DRAM and DRAM access modes and describes an i960 Cx processor-specific DRAM interface. Two specific design examples are also included: one design uses the integrated DMA unit to refresh the DRAM, the other example uses the  $\overline{\text{CAS}}$ -before- $\overline{\text{RAS}}$  method of refresh. Both designs illustrate the advantage of the i960 Cx processors' burst bus and the fast column address access times available on many modern DRAMs.

The burst bus and memory region configuration tables simplify DRAM interface to the i960 Cx processors. DRAM systems can be designed in many ways — there are memory access options, memory system configuration options and refresh mode options.

DRAM offers high data density, fast access times and low cost per bit. DRAM is available in a wide variety of packages, making it easy to pack a lot of memory into a small space. DRAM features described here are provided as general information. (See specific data sheets for detailed information.)

The i960 Cx processors' burst mode bus is well suited to the high speed multiple column access modes found in DRAM. Nibble, fast page and static column modes of DRAM can easily be exploited to improve i960 Cx processor memory system performance.

All DRAMs have a multiplexed address bus, a write enable input ( $\overline{\text{WE}}$ ) and two address strobes: row address strobe ( $\overline{\text{RAS}}$ ) and column address strobe ( $\overline{\text{CAS}}$ ). Some DRAMs also have an output enable input ( $\overline{\text{OE}}$ ). DRAMs are accessed by placing a valid row address on the address input pins and asserting  $\overline{\text{RAS}}$ ; then the column address is driven onto the DRAM address pins and  $\overline{\text{CAS}}$  is asserted. Write enable ( $\overline{\text{WE}}$ ) input on the DRAM determines whether the access is a read or write. Output enable input ( $\overline{\text{OE}}$ ) — found on some DRAMs — controls the DRAM output buffers and can be useful for multibanked and interleaved designs.

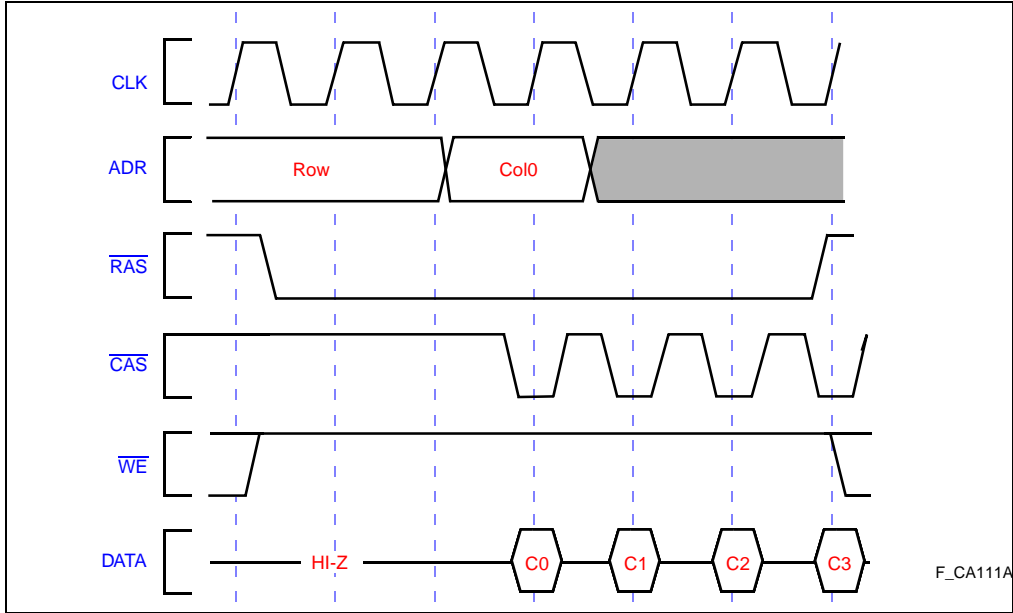
### B.3.1 DRAM Access Modes

The modes discussed in the following subsections are:

- section B.3.1.1, “Nibble Mode DRAM” (pg. B-16)
- section B.3.1.2, “Fast Page Mode DRAM” (pg. B-17)
- section B.3.1.3, “Static Column Mode DRAM” (pg. B-18)

**B.3.1.1 Nibble Mode DRAM**

Nibble mode DRAM (Figure B-11) allows up to four consecutive columns within a selected row to be read or written at a high data rate. A read or write cycle starts by asserting  $\overline{\text{RAS}}$ . Strobing  $\overline{\text{CAS}}$  accesses the consecutive column data. The input address is ignored after the first column access.



**Figure B-11. Nibble Mode Read**



### B.3.1.2 Fast Page Mode DRAM

Fast page mode DRAM (Figure B-12) is similar to nibble mode DRAM, except fast page mode allows any column within a selected row to be read or written at a high data rate. A read or write cycle starts by asserting  $\overline{\text{RAS}}$ . Strobing  $\overline{\text{CAS}}$  accesses the selected column data. During reads, the  $\overline{\text{CAS}}$  falling edge latches the address (internal to the DRAM) and enables the output. The processor's four word burst bus can easily take advantage of the faster column access times provided by fast page mode DRAM.

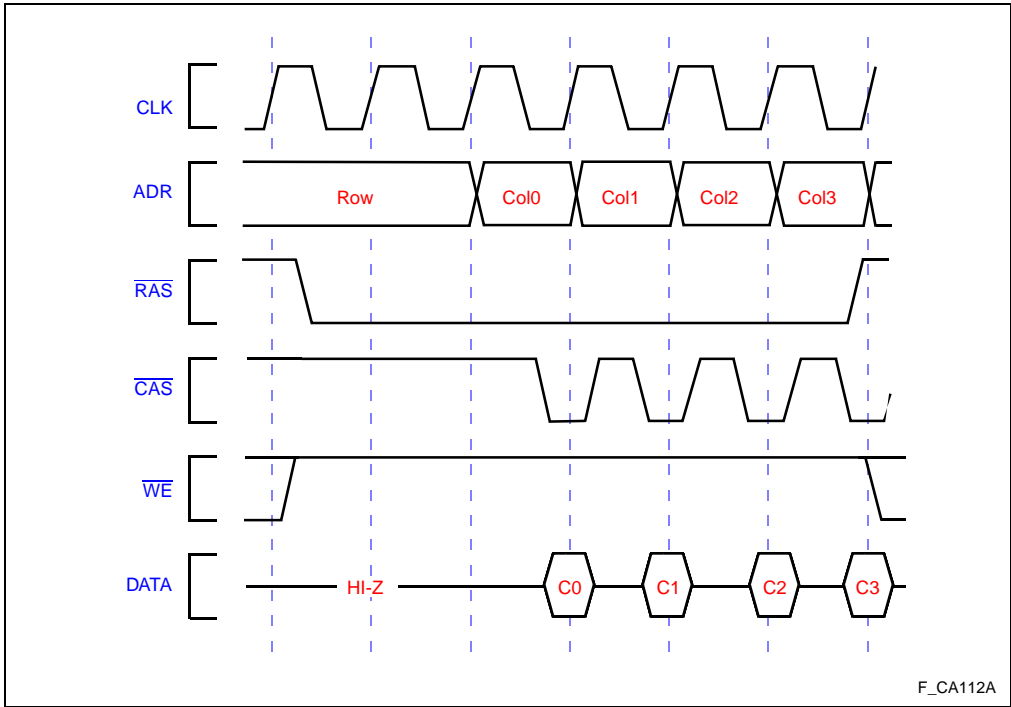
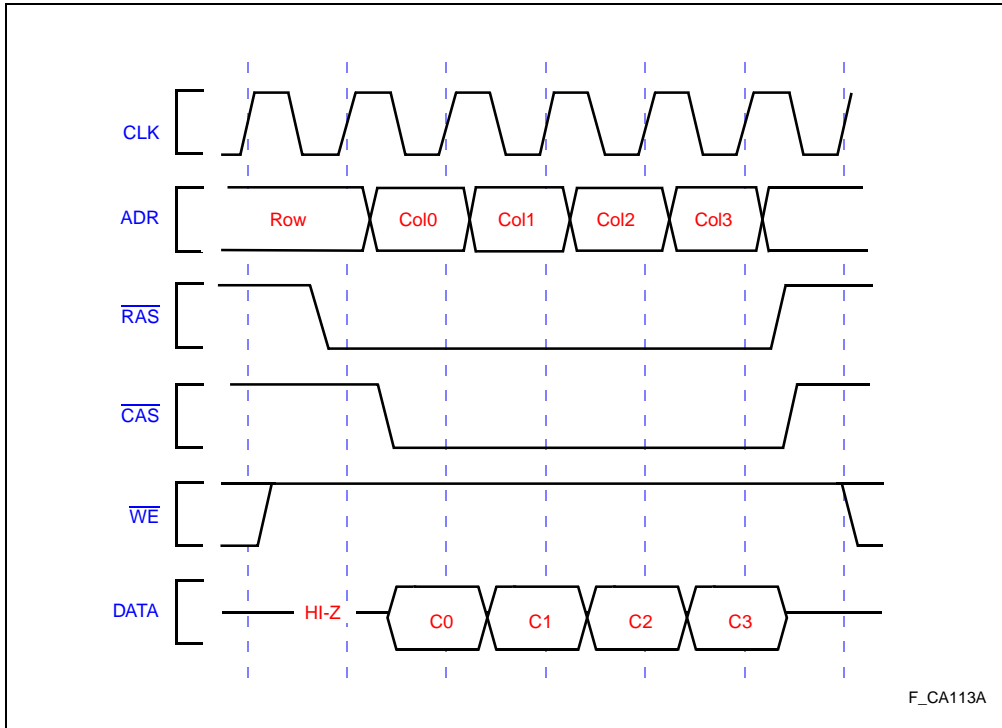


Figure B-12. Fast Page Mode DRAM Read



**B.3.1.3 Static Column Mode DRAM**

Static column mode DRAM write accesses (Figure B-13) are similar to fast page mode writes. Static column read cycles start by asserting  $\overline{RAS}$ . Accesses to any column within the selected row may be treated as static RAM, using  $\overline{CAS}$  as an output enable. The fastest DRAM read accesses are achieved with static column DRAM. The i960 Cx processors' four word burst bus can easily take advantage of the fast column access times provided by nibble mode, fast page mode or static column mode DRAM.



**Figure B-13. Static Column Mode DRAM Read**

**B.3.2 DRAM Refresh Modes**

All DRAMs require periodic refresh to retain data. DRAMs may be refreshed in one of two ways:  $\overline{RAS}$ -only refresh or  $\overline{CAS}$ -before- $\overline{RAS}$  refresh.  $\overline{RAS}$ -only refresh (Figure B-14) is realized by asserting a row address on the address pins and asserting  $\overline{RAS}$ .  $\overline{CAS}$  is not asserted. A single,  $\overline{RAS}$ -only refresh cycle refreshes all columns within the selected row.  $\overline{CAS}$ -before- $\overline{RAS}$  refreshes (Figure B-15) do not require an address to be generated; DRAM generates the row address with an internal counter.





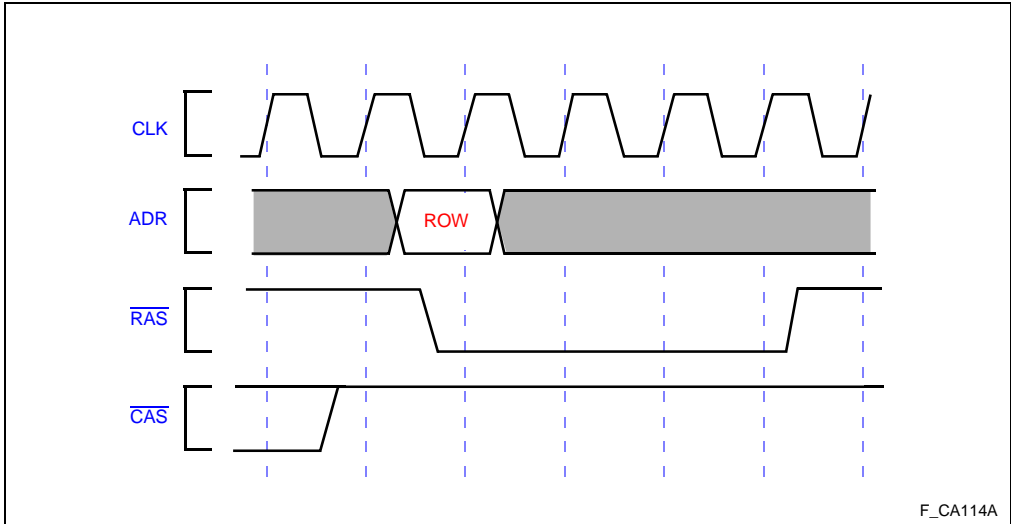


Figure B-14.  $\overline{\text{RAS}}$ -only DRAM Refresh

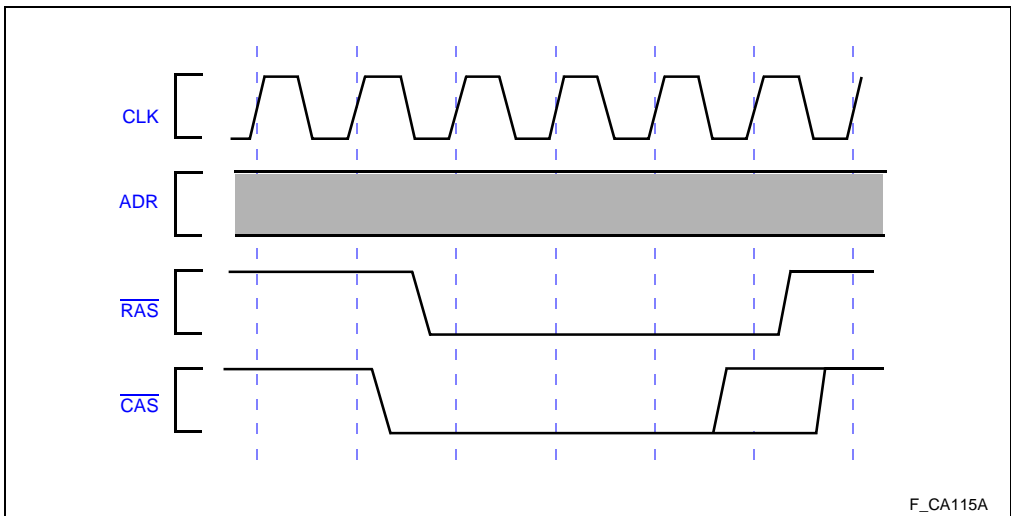


Figure B-15.  $\overline{\text{CAS}}$ -before- $\overline{\text{RAS}}$  DRAM Refresh

**B**

DRAM may be refreshed in either a distributed or a burst manner. Burst refresh does not refer to the burst access bus. The term simply means that all memory rows are sequentially accessed when the refresh interval time expires. Distributed refresh implies that refresh cycles are distributed within the refresh interval required by the memory.



Distributed refresh cycles are spread out over the refresh interval, reducing possible access latency. Burst refreshing may lock the processor out of the DRAM for a longer period of time; it may be inappropriate for some applications. Burst refreshing, however, guarantees that no refresh activity occurs between refresh intervals. Some applications may take advantage of this to burst refresh the DRAM during a time it will not be accessed, making refresh invisible to the application.

### B.3.3 Address Multiplexer Input Connections

Address multiplexer inputs can be ordered such that 256 Kbyte through 4 Mbyte DRAM can be supported. Interleaving the upper address signals provides compatibility with all these memory densities. Figure B-16 illustrates this arrangement. Availability of DRAM modules with standard pinouts makes this an attractive way to ensure future memory expansion.

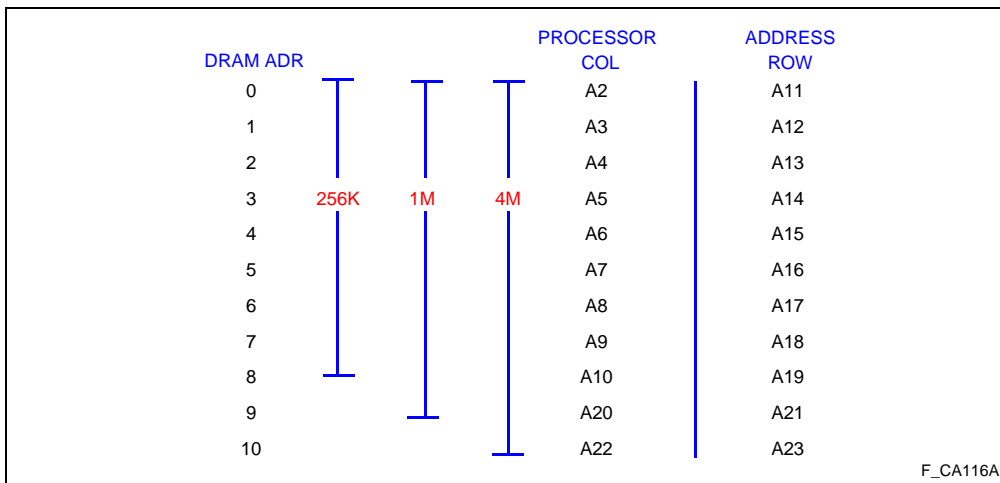


Figure B-16. Address Multiplexer Inputs

### B.3.4 Series Damping Resistors

Series-damping resistors are recommended on all DRAM control and address inputs. Series-damping resistors prevent overshoot and undershoot on input lines. Damping is required because of the large capacitive load present when many DRAMs are connected together, combined with circuit board trace inductance. Damping resistor values are typically between 15 and 100 Ohms, depending on the load; the lower the load, the higher the required damping resistor value. If the damping resistor value is too high, the signal will be overdamped, extending memory cycle time. If the damping resistor value is too low, overshoot or undershoot is not sufficiently damped.



### B.3.5 System Loading

The i960 Cx processors can drive a large capacitive load. However, systems with many DRAM banks may require data buffers and — for interleaved designs — multiplexers to isolate the DRAM load from the i960 Cx processors or other system components with less drive capability (e.g., high speed SRAM).

$\overline{\text{RAS}}$  and  $\overline{\text{CAS}}$  inputs to the DRAM should also be designed with consideration for capacitive load. When many DRAMs are connected to common  $\overline{\text{RAS}}$  and  $\overline{\text{CAS}}$  signals, the capacitive load can become considerable.

### B.3.6 Design Example: Burst DRAM with Distributed $\overline{\text{RAS}}$ Only Refresh Using DMA

The goal of this design is to illustrate a DRAM interface controller that provides good memory performance while maintaining controller independence with respect to memory speed and processor clock frequency. One of the four on-chip integrated DMA channels is used for DRAM refresh. The region table, DMA and the i960 Cx processor bus signals are used to develop a transparent DRAM controller that does not require any information about the memory subsystem.

Figure B-17 shows the DRAM system design. The DRAM is configured as a single, byte accessible, 32-bit-wide bank.  $\overline{\text{RAS}}$  is common to the entire bank;  $\overline{\text{CAS}}_{3:0}$  serve as byte selects within the bank.  $\overline{\text{WE}}$  is common to all the DRAM. The byte accessible bank can be built from four 8-bit-wide DRAM modules; eight 4-bit-wide DRAM modules; eight 4-bit-wide DRAM chips; or 32 1-bit-wide DRAM devices.

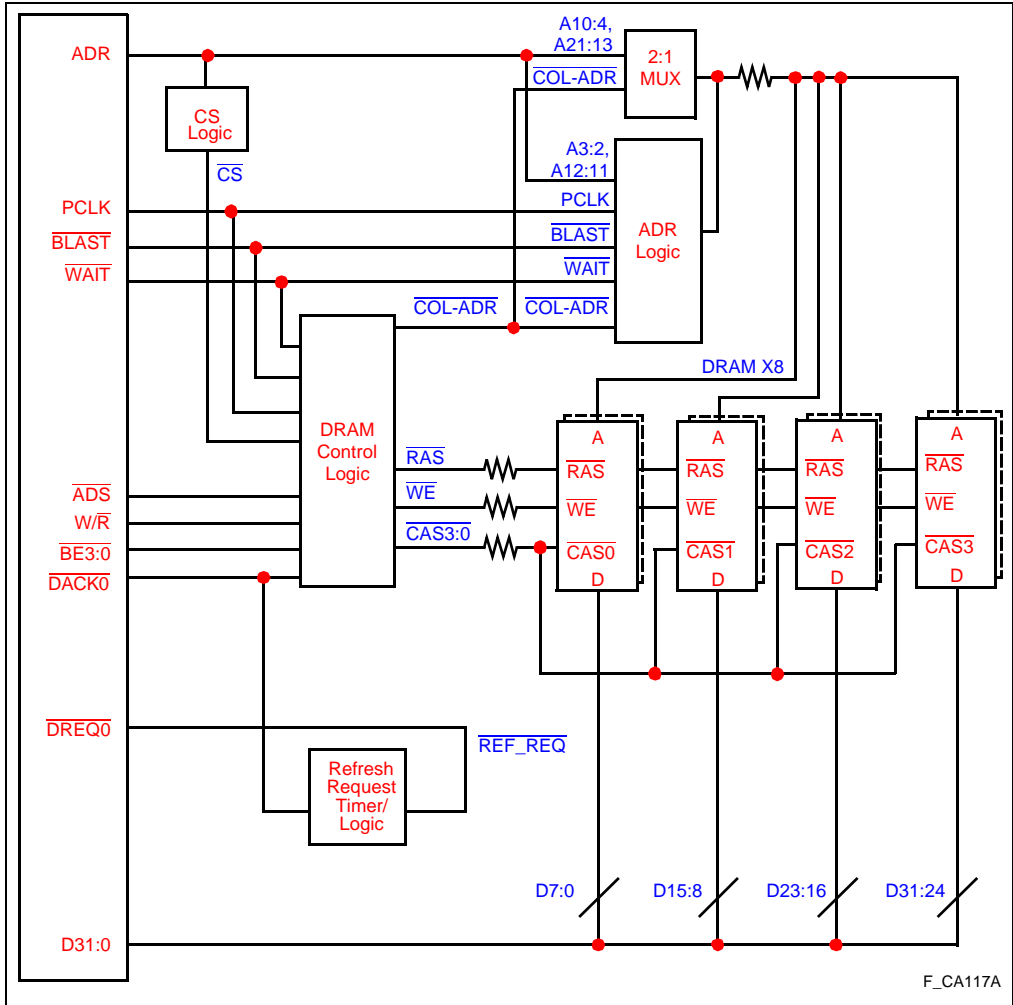


Figure B-17. DRAM System with DMA Refresh

Control logic is divided into three logical blocks: DRAM control logic, DRAM address generation logic and refresh request timer logic. DRAM control logic is the main controller. It controls the address multiplexer and all DRAM control lines during normal and refresh accesses. Address generation logic serves as a multiplexer and an address generator. The refresh request timer logic generates the periodic refresh request to the DMA unit.



### B.3.7 DRAM Address Generation

DRAM address generation logic speeds burst accesses for static column mode and fast page mode DRAM. This is accomplished by reducing the time required to present the consecutive column addresses during a burst access. If the address generator is not present, the address valid delay time consists of the worst-case address valid delay time plus the worst-case propagation delay through the input address multiplexer.

DRAM address generation logic must control the DRAM address two least significant bits. During the initial DRAM access, address generation logic acts like a multiplexer. During column accesses within a burst, address generation logic generates consecutive addresses. Therefore, DRAM address generation logic is designed to function as a multiplexer and an address generator.

If an address generator is used, address valid delay time is equal to address generation time. Address generation delay time consists of the clock-to-feedback and feedback-to-output delays for the selected device.

Figure B-18 illustrates the requirements for address generation logic. Signals into the DRAM logic are: ADR2, ADR3, ADR12, ADR13,  $\overline{\text{WAIT}}$  and  $\overline{\text{BLAST}}$  from the processor and  $\overline{\text{COL\_ADR}}$  from the DRAM controller logic.  $\overline{\text{COL\_ADR}}$  indicates if the DRAM controller is requesting the row address ( $\overline{\text{COL\_ADR}}$  not asserted) or column address ( $\overline{\text{COL\_ADR}}$  asserted). Signals output from DRAM address generation logic are the DRAM address two least significant bits, DRAM\_ADR2:3. The pseudo-code following the figure is provided only to describe the state machine diagram. It is not intended for direct use as PLD equations.

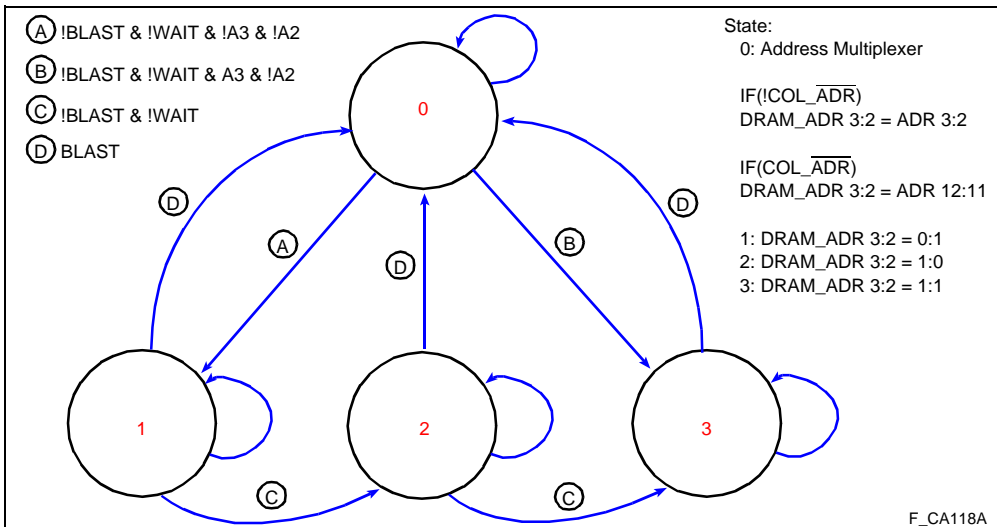


Figure B-18. DRAM Address Generation State Machine



```

STATE_0:          /* Multiplexer Emulation */
                 DRAM_ADR2 = (!COL_ADR && A2) || (COL_ADR && A11);
                 DRAM_ADR3 = (!COL_ADR && A3) || (COL_ADR && A12);
                 IF          /* address generation */
                   WAIT && !BLAST && COL_ADR
                     && (ADR3 == 0) && (ADR2 == 0);
                 THEN
                   next state is STATE_1;
                 ELSE IF
                   WAIT && BLAST && COL_ADR
                     && (ADR3 == 1) && (ADR2 == 0);
                 THEN
                   next state is STATE_3;
                 ELSE
                   next state is STATE_0;
STATE_1:          /* Generate address 01 */
                 DRAM_ADR2 = 1;
                 DRAM_ADR3 = 0;
                 IF
                   BLAST;
                 THEN
                   next state is STATE_0;
                 ELSE IF
                   BLAST && WAIT;
                 THEN
                   next state is STATE_2;
                 ELSE
                   next state is STATE_1;
STATE_2:          /* Generate address 10 */
                 DRAM_ADR2 = 0;
                 DRAM_ADR3 = 1;
                 IF
                   BLAST;
                 THEN
                   next state is STATE_0;
                 ELSE IF
                   BLAST && WAIT;
                 THEN
                   next state is STATE_3;
                 ELSE
                   next state is STATE_2;
STATE_3:          /* Generate address 11 */
                 DRAM_ADR0 = 1;
                 DRAM_ADR1 = 1;
                 IF
                   BLAST;
                 THEN
                   the next state is STATE_0;
                 ELSE
                   next state is STATE_3

```

### B.3.8 DRAM Controller State Machine

Figure B-19 is a state machine that describes DRAM control logic. The state machine shown, or subsets thereof, may be implemented in a variety of ways depending on the application's requirements. PLD implementations are the easiest and the design may fit into a variety of high speed PLDs.

Signals going into the DRAM control logic are:  $\overline{ADS}$ ,  $PCLK$ ,  $W/\overline{R}$ ,  $\overline{BLAST}$ ,  $\overline{WAIT}$ ,  $\overline{BE3:0}$  from the bus controller;  $\overline{DACK0}$ , the DMA acknowledge signal; and  $\overline{DRAM\_CS}$ , a system generated chip select that indicates a DRAM access. DRAM control logic generates  $\overline{RAS}$ ,  $\overline{CAS3:0}$ ,  $\overline{WE}$  and  $\overline{COL\_ADR}$ . Control signal for the address multiplexer is  $\overline{COL\_ADR}$ .

Controller logic relies on the wait state region table and DMA controller. Programming these on-chip peripherals is described later. DMA acknowledge,  $\overline{DACK0}$ , indicates a DRAM refresh cycle. The DRAM  $\overline{WE}$  signal is generated with combinatorial logic ( $\overline{WE} =!(W/\overline{R})$ ).

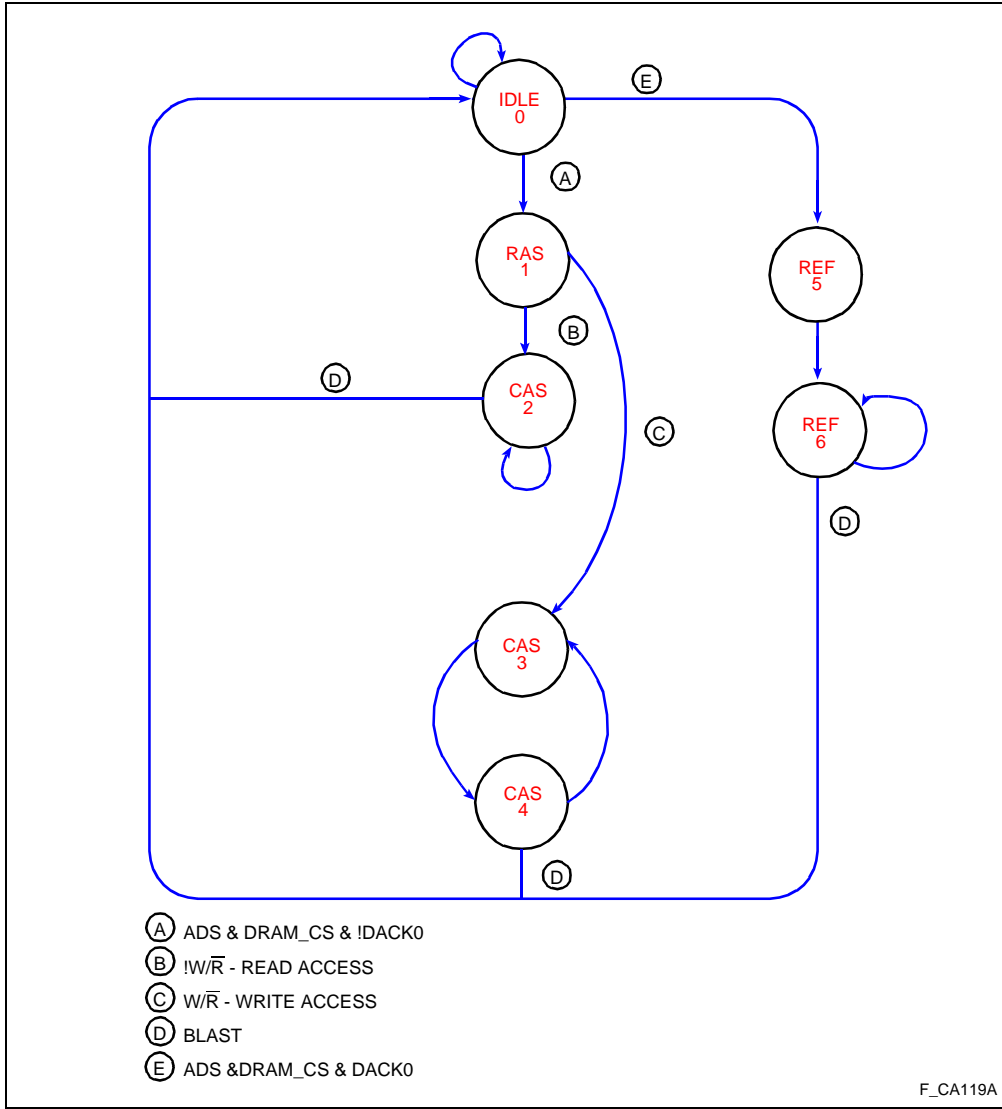


Figure B-19. DRAM Controller State Machine

```

STATE_0:                                     /* Idle */
    RAS          is not asserted;
    CAS3:0       is not asserted;
    COL_ADR      is not asserted;
    IF           /* memory access */
        ADS && DRAM_CS && !DACK0;
  
```





```

        THEN
            the next state is STATE_1;
        ELSE IF /* refresh access */
            ADS && DRAM_CS && DACK0;
        THEN
            the next state is STATE_5;
        ELSE
            the next state is STATE_0;
STATE_1:
        RAS          is asserted;
        CAS3:0       is not asserted;
        COL_ADR      is not asserted;
        IF
            WRITE;
        THEN
            the next state is STATE_3;
        ELSE
            the next state is STATE_2;
STATE_2:
        /*Static Column Mode Read, Assert  $\overline{\text{CAS}}$  */
        RAS          is asserted;
        CAS3:0       is asserted;
        COL_ADR      is asserted;
        IF
            BLAST;
        THEN
            the next state is STATE_0;
        ELSE
            the next state is STATE_2;
STATE_3:
        /* Select Column Address */
        RAS          is asserted;
        CAS3:0       is not asserted;
        COL_ADR      is asserted;
        the next state is STATE_4;
STATE_4:
        /* Assert  $\overline{\text{CAS}}$  */
        RAS          is asserted;
        COL_ADR      is asserted;
        CAS0 = BE0;
        CAS1 = BE1;
        CAS2 = BE2;
        CAS3 = BE3;
        IF
            WAIT && BLAST;
        THEN
            the next state is STATE_3;
        ELSE IF
            BLAST
        THEN
            the next state is STATE_0;
        ELSE
            the next state is STATE_4;
        the next state is STATE_6;
STATE_5:
        /* REFRESH CYCLE,  $\overline{\text{RAS}}$  ONLY REFRESH */

```

B

```

        RAS      is not asserted;
        CAS3:0   is not asserted;
        COL_ADR  is asserted;
STATE_6:                                /* REFRESH CYCLE, Assert  $\overline{\text{RAS}}$  */
        RAS      is asserted;
        CAS3:0   is not asserted;
        COL_ADR  is asserted;
        IF
            BLAST;
        THEN
            the next state is STATE_0;
        ELSE
            the next state is STATE_6;
    
```

### B.3.9 DRAM Refresh Request and Timer Logic

DRAM refresh request and timer logic is responsible for generating DMA requests at an appropriate interval and for removing the DMA request after receiving DMA acknowledge.

Typical DRAM must be refreshed every 4 ms; refresh cycles must be performed on all 256 rows during this 4 ms interval. If a distributed refresh method is chosen, a refresh cycle must be performed every 15  $\mu\text{s}$ . The time base can be generated from a counter connected to PCLK, a timer counter chip or any other time base. DMA request and acknowledge signals are shown in Figure B-20.

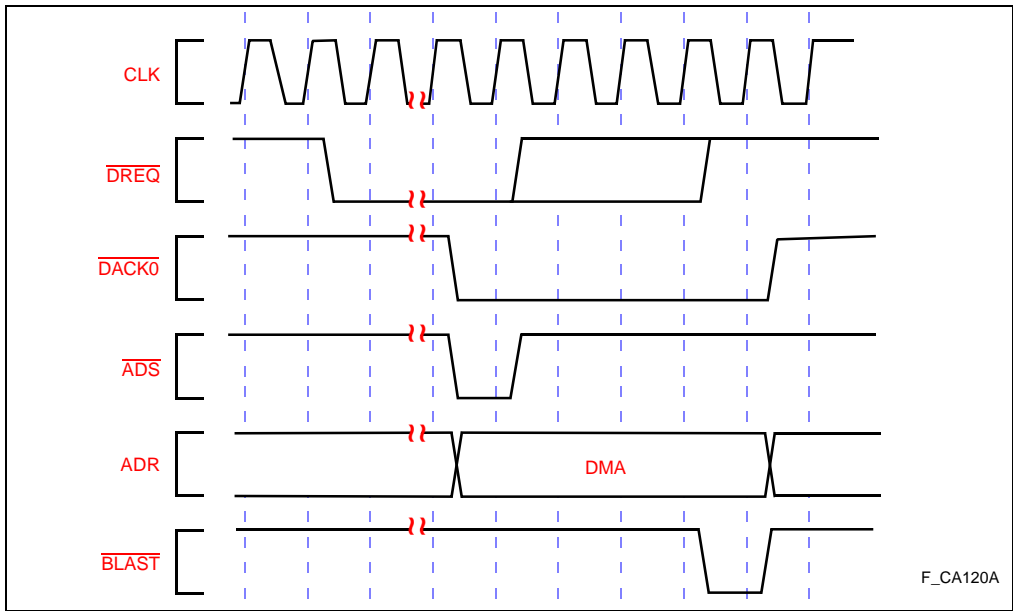


Figure B-20. DMA Request and Acknowledge Signals



### B.3.10 DMA Programming for Refresh

DMA should be programmed to perform 32-bit, fly-by, source synchronized demand mode transfers with source chaining. The chaining must be set up to perform an infinite loop of transfers. When all transfers are complete and all rows are refreshed, the cycle begins again. See Figure B-21 for chaining description.

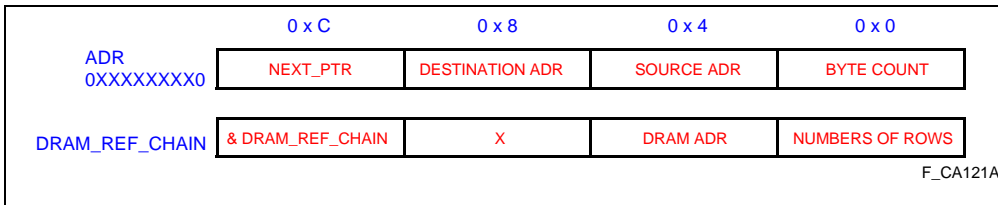


Figure B-21. DMA Chaining Description

### B.3.11 Memory Ready

The memory ready input to the i960 Cx processors' ( $\overline{\text{READY}}$ ) indicates the completion of a DRAM read or write cycle.  $\overline{\text{READY}}$  must be generated by the DRAM controller and must satisfy setup and hold times specified in the data sheet. If multiple memory systems are using  $\overline{\text{READY}}$ , ready signals from these memory systems must be logically ORed together.

### B.3.12 Region Table Programming

Region table programming is critical to DRAM operation.  $N_{\text{RAD}}$  and  $N_{\text{WAD}}$  wait states must satisfy  $\overline{\text{RAS}}$ ,  $\overline{\text{CAS}}$  and address valid times for the DRAM.  $N_{\text{RDD}}$  and  $N_{\text{WDD}}$  times must satisfy the column address to data access times. The  $N_{\text{XDA}}$  time must satisfy  $\overline{\text{RAS}}$  precharge time. Figures B-22 and B-23 show typical system waveforms for this design. Note that  $\overline{\text{RAS}}$  is not asserted until the end of the address cycle; this delay contributes to  $\overline{\text{RAS}}$  precharge time. In some DRAM designs, it may be possible to remove  $\overline{\text{RAS}}$  before access is complete. This is especially true for static column reads and multiple word access. If  $\overline{\text{RAS}}$  can be removed early in the access,  $\overline{\text{RAS}}$  precharge can occur during the access.



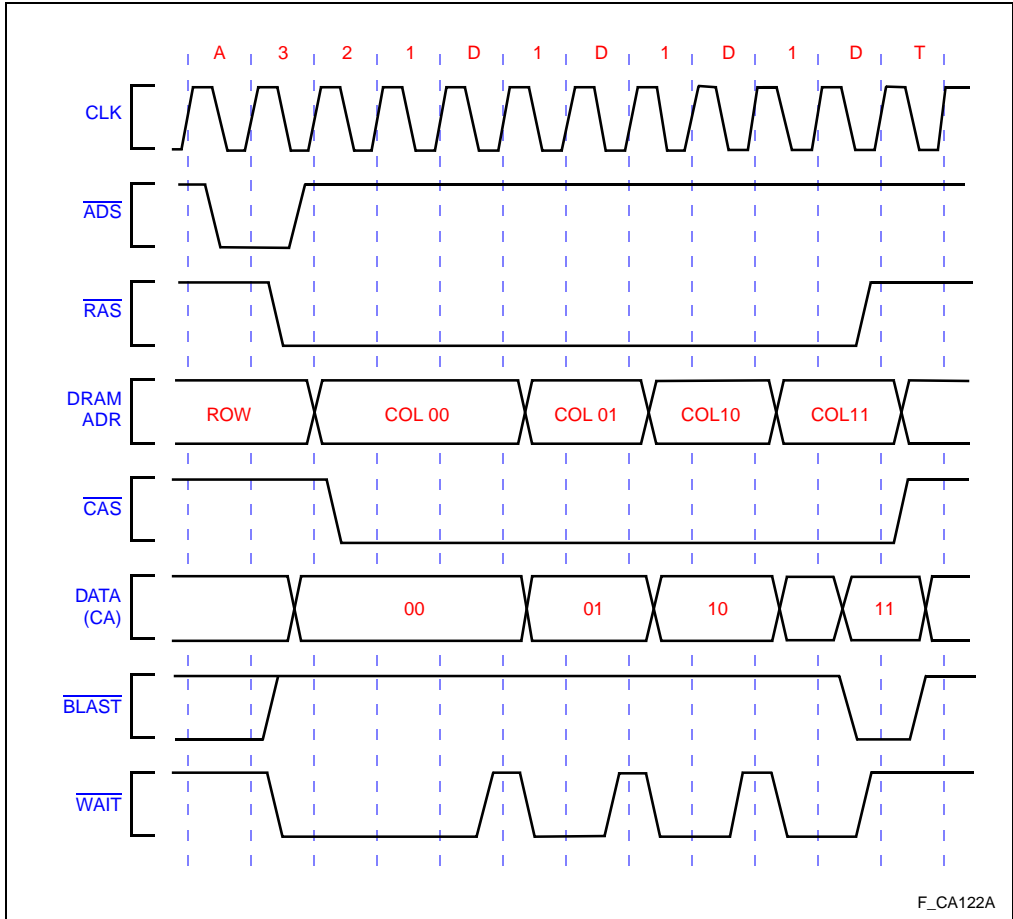


Figure B-22. DRAM System Read Waveform



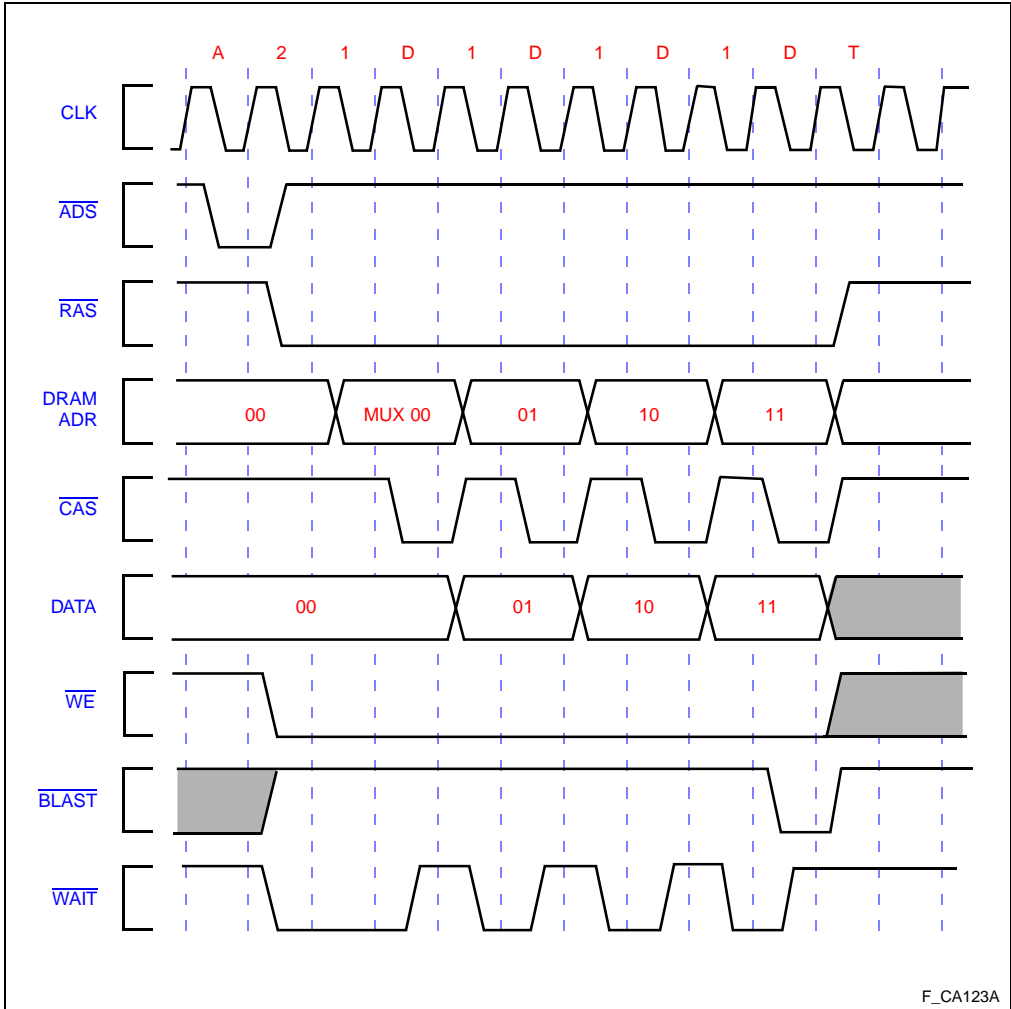


Figure B-23. DRAM System Write Waveform

B

**B.3.13 Design Example: Burst DRAM with Distributed  $\overline{\text{CAS}}$ -Before- $\overline{\text{RAS}}$  Refresh Using  $\overline{\text{READY}}$  Control**

This example illustrates a DRAM system design that uses  $\overline{\text{CAS}}$ -before- $\overline{\text{RAS}}$  refresh and  $\overline{\text{READY}}$  control.  $\overline{\text{CAS}}$ -before- $\overline{\text{RAS}}$  refresh uses the internal refresh address generation capabilities of modern DRAMs. The design does not use a DMA channel for refresh.  $\overline{\text{READY}}$  must be generated by the DRAM controller to indicate that a data transfer is complete. The controller must arbitrate between access requests and refresh requests, control the address multiplexer and  $\overline{\text{RAS}}$  precharge time. The internal wait state generator is not used. The DRAM controller must be designed with information about processor and DRAM speed.

The memory system block diagram (Figure B-24) is similar to the schematic for the previous example, except for the absence of the DMA controller connection. The refresh timer indicates it is time to refresh the DRAM.

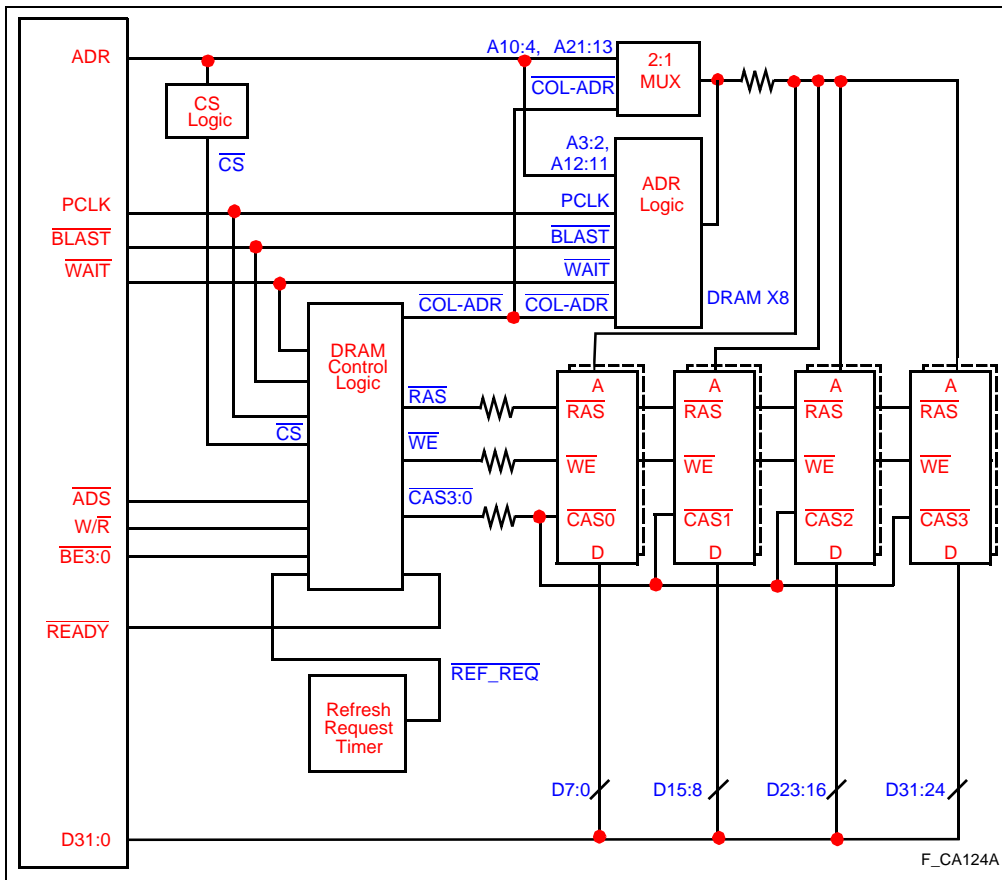
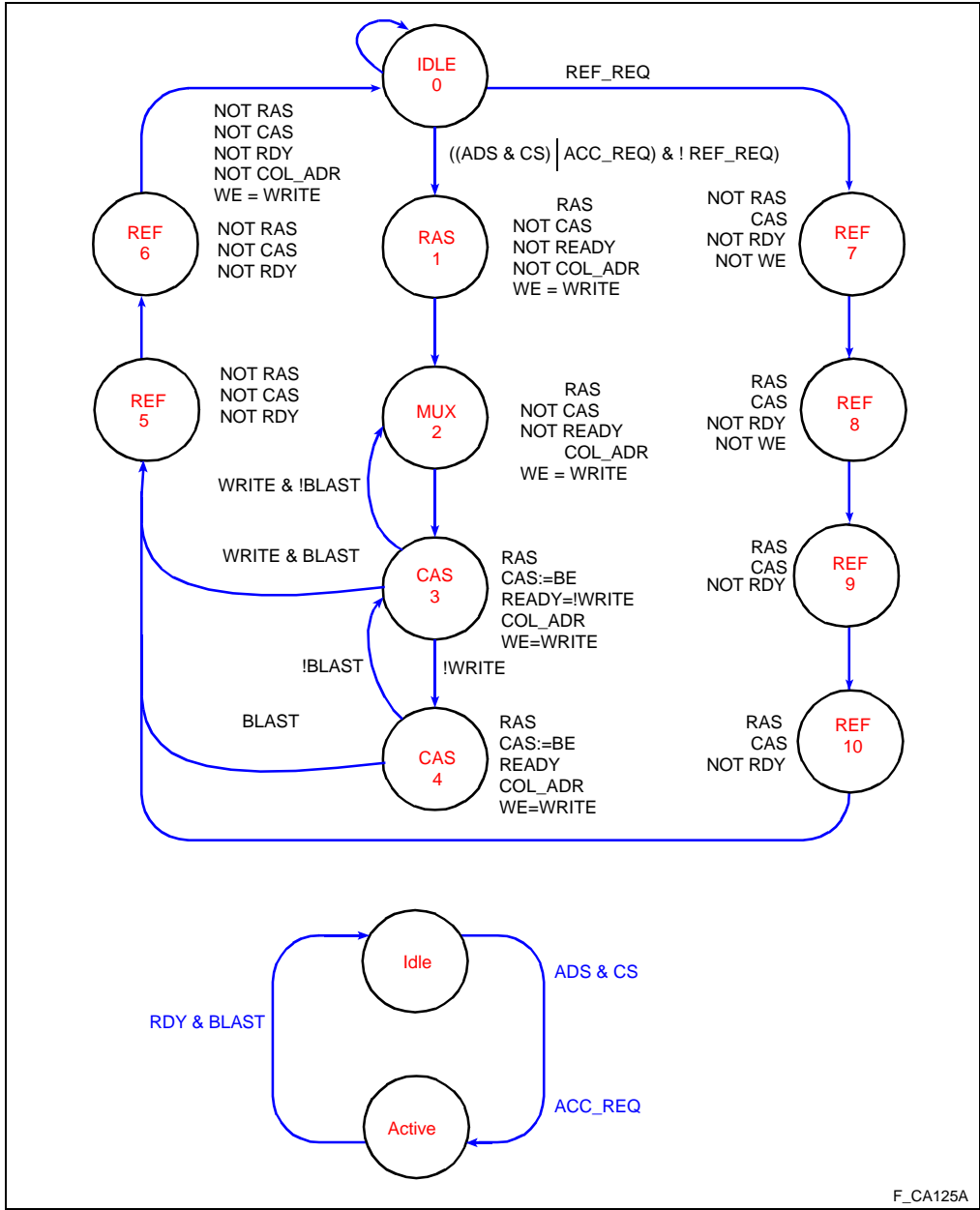


Figure B-24. Memory System Block Diagram

### B.3.14 DRAM Controller State Machine

The state machine in Figure B-25 is more complicated than the state machine in the previous example. This is because the controller works without the help of the internal wait-state generator. There are two advantages of this design over the previous example: a DMA channel is not used and the refresh cycle does not require the processor bus. Not using a DMA channel for DRAM refresh makes the DMA channel available for other applications within the system.

$\overline{\text{CAS}}$ -before- $\overline{\text{RAS}}$  refresh mode does not require the bus or any processor intervention; therefore, DRAM refresh occurs autonomously. The DRAM controller state machine described here assumes 80 ns static column mode DRAM with a 33 MHz clock (PCLK). This DRAM controller does not require the internal wait state generator; as a result, all wait state parameters can be programmed to zero (0).



F\_CA125A

Figure B-25. DRAM State Machine



The refresh request timer generates the refresh request signal ( $\overline{\text{REF\_REQ}}$ ), indicating that it is time to refresh the DRAM. The controller gives preference to refresh requests over access requests. This ensures that the entire memory remains refreshed. The access request signal ( $\text{ACC\_REQ}$ ) shown on the state diagram is a latched signal.  $\text{ACC\_REQ}$  is asserted when  $\overline{\text{ADS}}$  and  $\overline{\text{DRAM\_CS}}$  are both asserted.  $\text{ACC\_REQ}$  is deasserted when  $\overline{\text{BLAST}}$  is asserted. It is necessary to latch the access request because the controller could be in a refresh or  $\overline{\text{RAS}}$  precharge state when the processor accesses the DRAM.

The pseudo-code description below is provided only to describe the state machine diagram. It is not intended to be used directly as PLD equations.

```

STATE_0:                                     /* Idle */
    RAS          is not asserted;
    CAS3:0       is not asserted;
    COL_ADR      is not asserted;
    READY        is not asserted;
    WE = W/R;
    IF
        REF_REQ;
    THEN
        the next state is STATE_7; /* Refresh */
    ELSE IF
        (ADS && DRAM_CS) || ACC_REQ;
    THEN
        the next state is STATE_1; /* Access*/
    ELSE
        the next state is STATE_0; /* Idle */
STATE_1:                                     /* Assert  $\overline{\text{RAS}}$  */
    RAS          is asserted;
    CAS3:0       is not asserted;
    COL_ADR      is not asserted;
    READY        is not asserted;
    WE = W/R;
    the next state is STATE_2;
STATE_2:                                     /* MUX the address */
    RAS          is asserted;
    CAS3:0       is not asserted;
    COL_ADR      is asserted;
    READY        is not asserted;
    WE = W/R;
STATE_3:                                     /* Assert  $\overline{\text{CAS}}$ , write is
                                             ready, read is not */
    RAS          is asserted;
    CAS3:0 = BE3:0;
    COL_ADR      is asserted;
    READY = !W/R;
    WE = W/R;
    IF
        W/R && BLAST; /* Write access not done */
    THEN

```

```

STATE_0:                                     /* Idle */
        the next state is STATE_2; /* remove  $\overline{\text{CAS}}$  */
ELSE IF
    W/ $\overline{\text{R}}$  && BLAST;           /* Write Finished*/
THEN
    the next state is STATE_5;           /* $\overline{\text{RAS}}$  Precharge*/
ELSE                                     /* !W/ $\overline{\text{R}}$ , Read*/
    the next state is STATE_4;           /* Read */
STATE_4:                                     /* Read data ready */
    RAS          is asserted;
    CAS3:0 = BE3:0;
    COL_ADR      is asserted;
    READY        is asserted;
    WE = W/R;
    IF
        BLAST                                     /* read not Done */
    THEN
        the next state is STATE_3;           /* Remove READY */
    ELSE                                       /* BLAST, Read Done */
        the next state is STATE_5;           /* $\overline{\text{RAS}}$  Precharge*/
    the next state is STATE_3;
STATE_5:                                     /*  $\overline{\text{RAS}}$  Precharge */
    RAS          is not asserted;
    CAS3:0       is not asserted;
    COL_ADR = X;
    READY        is not asserted;
    WE = X;
        the next state is STATE_6;
STATE_6:                                     /* More  $\overline{\text{RAS}}$  Precharge */
    RAS          is not asserted;
    CAS3:0       is not asserted;
    COL_ADR = X;
    READY        is not asserted;
    WE = X;
        the next state is STATE_0;           /*Return to idle*/
STATE_7:                                     /* Refresh, assert  $\overline{\text{CAS}}$  */
    RAS          is not asserted;
    CAS3:0       is asserted;
    COL_ADR = X;
    READY        is not asserted;
    WE           is not asserted;
        the next state is STATE_8;
STATE_8:                                     /* Refresh, assert  $\overline{\text{RAS}}$  */
    RAS          is asserted;
    CAS3:0       is asserted;
    COL_ADR = X;
    READY        is not asserted;
    WE           is not asserted;
        the next state is STATE_8;STATE_9:   /* Refresh Hold
                                                 $\overline{\text{RAS}}$  */
    RAS          is asserted;
    CAS3:0       is asserted;

```

```

STATE_0:                                     /* Idle */
    COL_ADR = X;
    READY    is not asserted;
    WE = X;
        the next state is STATE_10;
STATE_10:                                     /* Refresh Hold  $\overline{RAS}$  */
    RAS      is asserted;
    CAS3:0   is asserted;
    COL_ADR = X;
    READY    is not asserted;
    WE       is not asserted;
        the next state is STATE_5;           /* $\overline{RAS}$  Precharge*/
    
```

### B.4 INTERLEAVED MEMORY SYSTEMS

Interleaving memory can provide a significant improvement in memory system performance. Interleaved memory systems overlap accesses to consecutive addresses; this results in higher performance with slower memory. Two-way memory interleaving is accomplished by dividing the memory into banks: one bank for even word addresses, one for odd word addresses. The least significant address bit (A2) is used to select a bank. The two banks are read in parallel and the data is put onto the data bus by a multiplexer. This can allow the wait states of the second access to be overlapped with the data transfer of the first access. Figure B-26 shows the access overlap for a burst access.

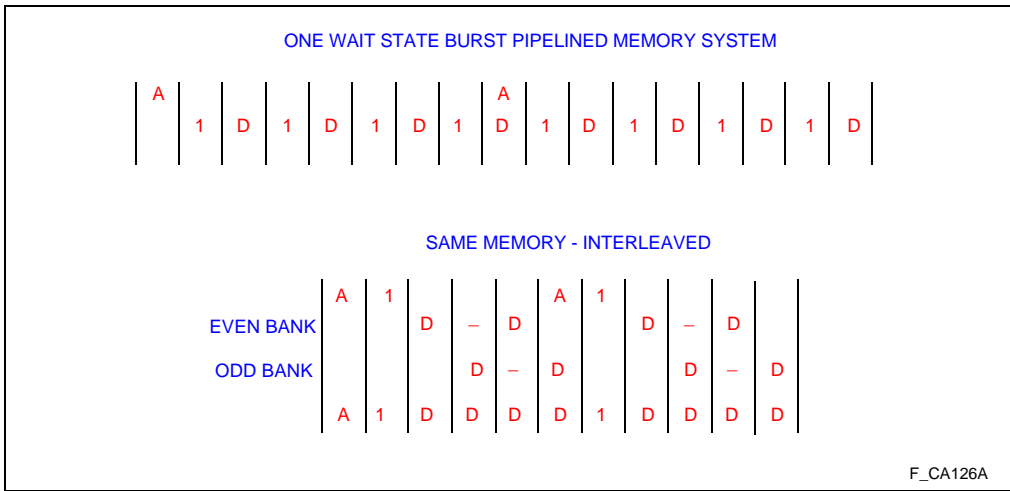


Figure B-26. Two-Way Interleaved Read Access Overlap



## BUS INTERFACE EXAMPLES

Figure B-27 is a simple schematic of a two-way, interleaved, pipelined memory system. The design is similar to the design of a non-interleaved pipelined memory design with the following exceptions:

- an output data multiplexer is used to prevent data contention
- the write data buffers isolate the memory data buses for writes
- the low address bit to the memory devices is A3

The A2 address determines which bank (even or odd word) is selected. Figure B-28 shows the read waveform.

Figure B-28 illustrates a memory system that interleaves read accesses. Write interleaving requires latching the written data and controlling memory access with the  $\overline{\text{READY}}$  signal. Write interleaving provides less performance improvement than read interleaving. Write data must come from the processor; this means a write interleaved system must queue data. The i960 Cx processor bus controller queues all access; therefore, write interleaving does not significantly benefit most applications.



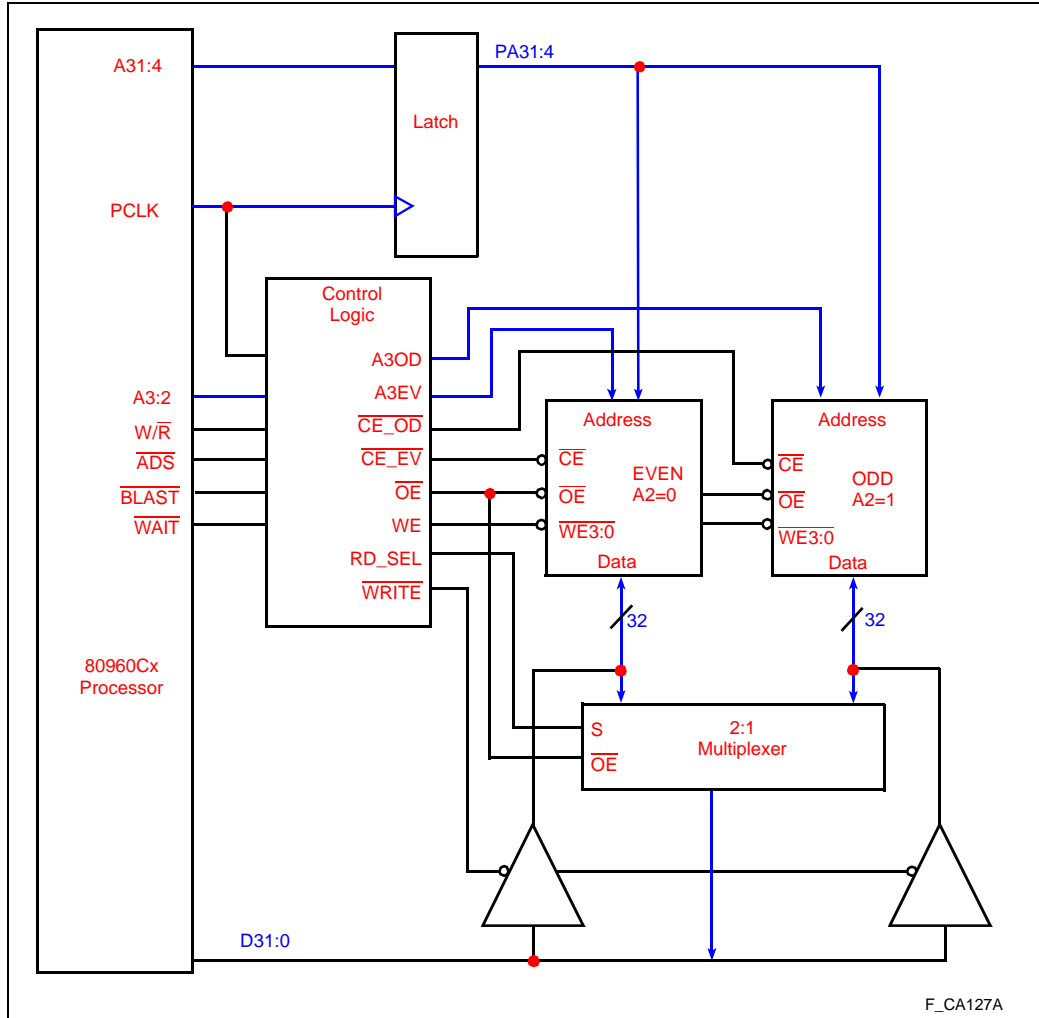


Figure B-27. Two-Way Interleaved Memory System

Memory interleaving can be applied to SRAM, DRAM and even EPROM memory systems. Interleaved SRAM and EPROM memory systems overlap access times for consecutive accesses to improve memory system performance. The i960 Cx processors' pipelined read mode can be used on SRAM and EPROM systems to further increase memory system performance. However, pipelined read mode is not appropriate for DRAM memory systems that require  $N_{XDA}$  states or  $\overline{READY}$  control. Interleaved DRAM memory systems can overlap the memory access time and  $\overline{RAS}$  precharge time of consecutive accesses.

**B**

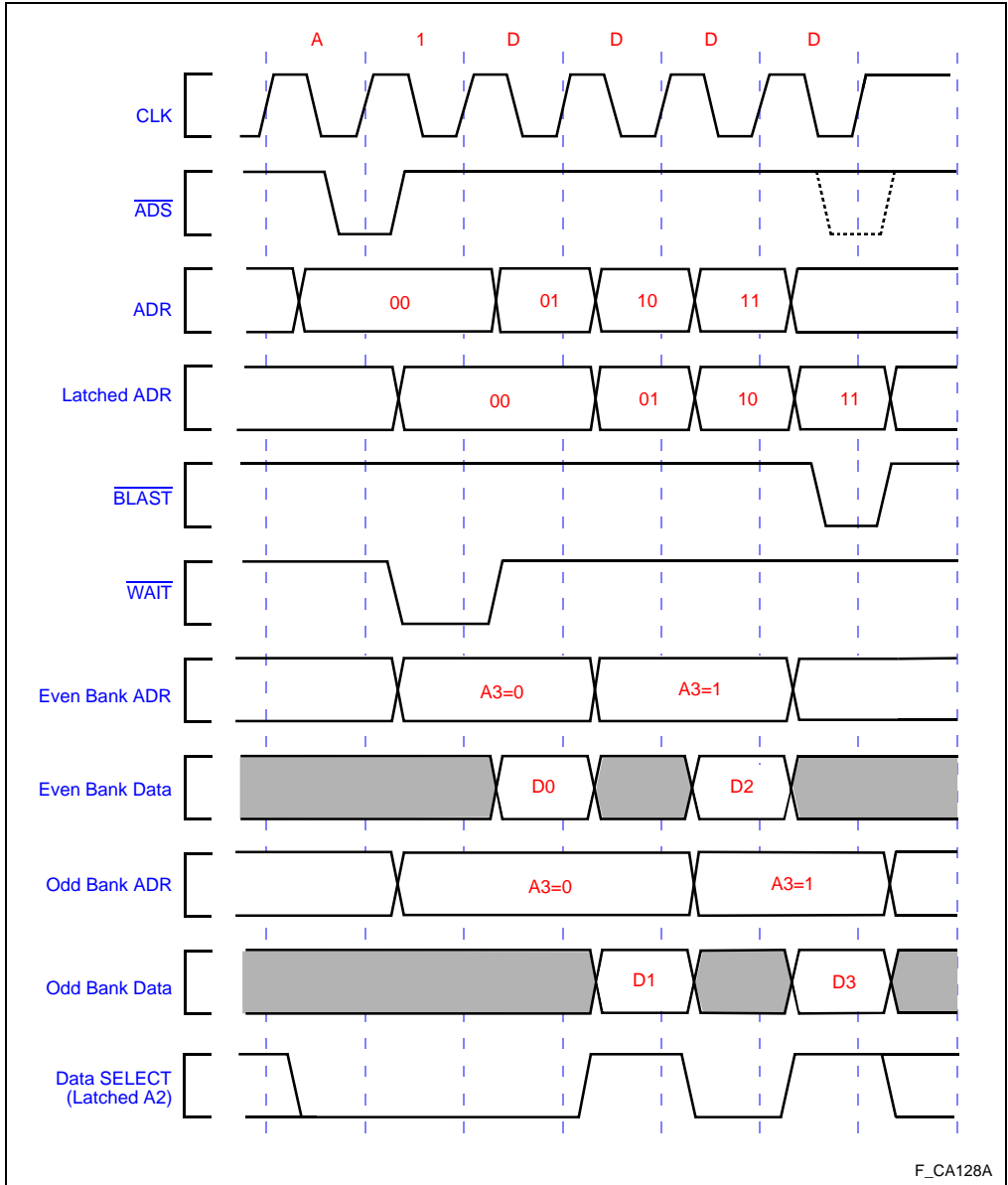


Figure B-28. Two-Way Interleaved Read Waveforms



## B.5 INTERFACING TO SLOW PERIPHERALS USING THE INTERNAL WAIT STATE GENERATOR

This section illustrates how easy it is to interface slow peripherals to the i960 Cx processor. This example shows the interface to an Intel 82C54-2 Timer/Counter and an Intel 82510 UART. The integrated internal wait state generator, programmable data bus width and data transceiver control signals simplify the logic required to implement the interface.

A system may require several slower-speed peripherals; other peripherals may use the interface described here.

### B.5.1 Implementation

Both the 82C54-2 Timer/Counter and 82510 UART have address, read, write and chip enable inputs and an 8-bit bidirectional data bus. The slow peripherals example considers only the memory mapped interface to chip control registers. The 82C54-2 and 82510 are memory mapped into a memory region programmed for non-burst, non-pipelined reads and an 8-bit data bus.

The  $\overline{RD}$  high to data float time dictates the number of  $N_{XDA}$  wait states required. Recovery time between reads or writes requires special treatment. The following example assumes a 33 MHz bus. The issues are the same at other operating frequencies.

### B.5.2 Schematic

The interface consists of chip select logic, a registered PLD with at least two combinatorial outputs and a data transceiver.

Chip select logic is the same as in previous examples. A simple demultiplexer is based only on the address. The PLD that controls access qualifies this signal with the address strobe ( $\overline{ADS}$ ).

The state machine PLD generates chip enable, read and write signals for the UART and Timer/Counter. It also generates the data enable control for the data transceiver. The A3 address signal determines which peripheral is enabled.

The data transceiver is enabled by the PLD. The transceiver is activated when both the  $\overline{CS}$  and  $\overline{DEN}$  signals are asserted. The equation is:

$$\overline{DATA\_8\_EN} = \overline{CS} | \overline{DEN}$$

Equation B-3

B

Transceiver direction control is connected directly to the DT/ $\overline{R}$  signal of the i960 Cx devices. Data transceiver usage is optional; it is used here to reduce capacitive loading on the data bus. The i960 Cx processors can drive substantial capacitive loads; however, high-speed SRAM may have limited drive capabilities. If high-speed SRAM is on the data bus, it may be necessary to buffer the slower peripherals.

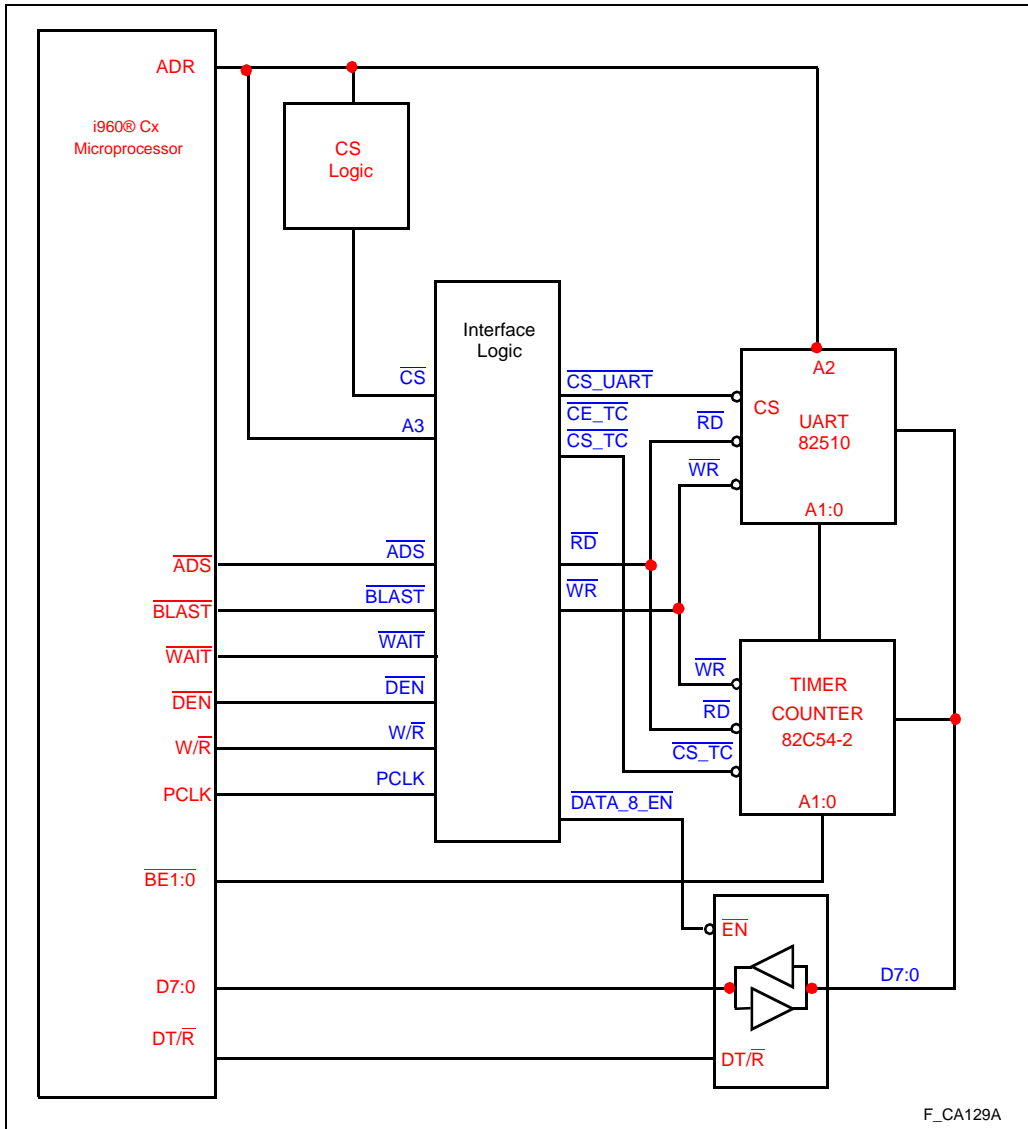


Figure B-29. 8-bit Interface Schematic





B.5.3 Waveforms

The Timer/Counter and UART have long address setup times to read or write. They also have long read and write recovery times. This design uses a PLD to implement a state machine that delays the read or write signal. Delaying the read or write signal satisfies command recovery times. Using the internal wait state generator to determine the length of the overall read or write cycle adds flexibility and simplifies the state machine.

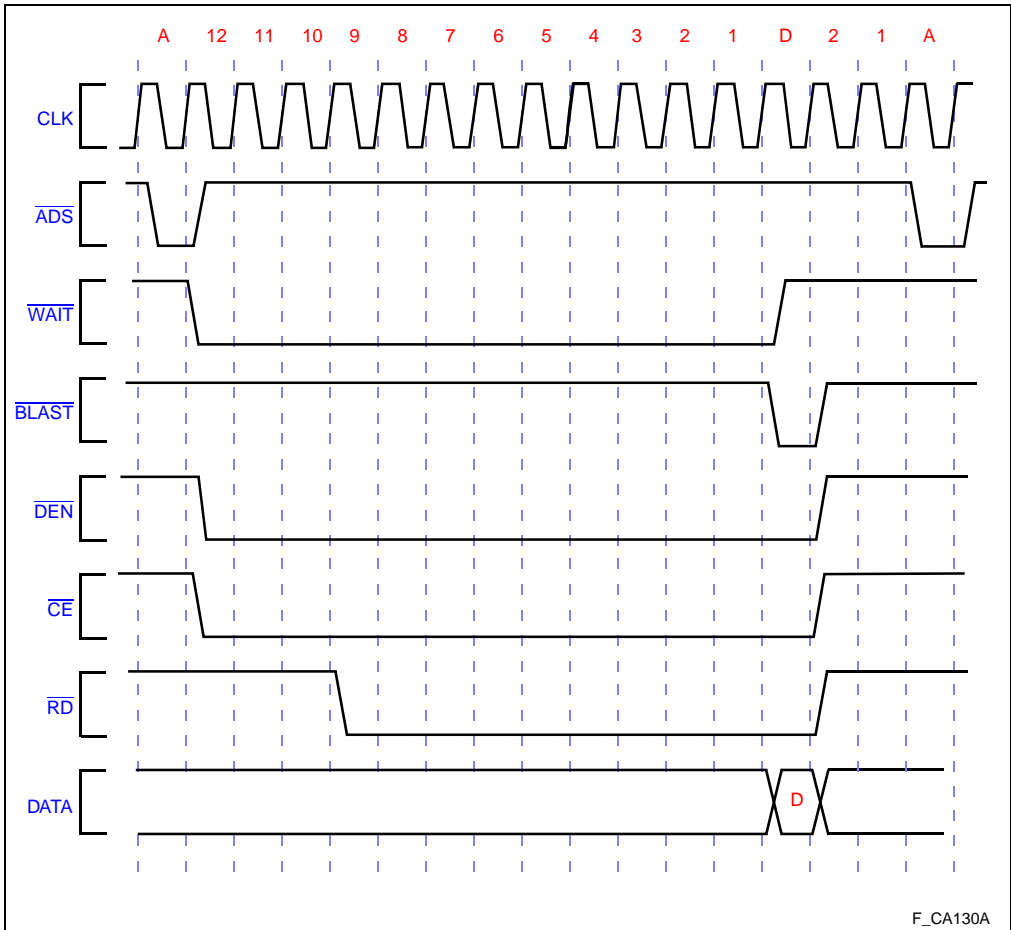


Figure B-30. Read Waveforms



Data lines are not driven during  $N_{XDA}$  wait states. This requires gating the  $\overline{W/R}$  signal with the  $\overline{WAIT}$  signal, so that  $\overline{W/R}$  goes high while the data is still asserted. There is a relative timing for output data hold after  $\overline{WAIT}$  goes high. The data hold requirement of the peripheral and the delay time to gate the write signal with  $\overline{WAIT}$  determines if this is an appropriate solution.

The state machine simply delays the read or write signal so that back-to-back commands to the peripheral satisfy the peripheral's command recovery time. When the write state is entered, the  $\overline{W/R}$  output of the PLD is a gated version of the  $\overline{WAIT}$  signal. This guarantees that the peripheral's write data hold time is satisfied.

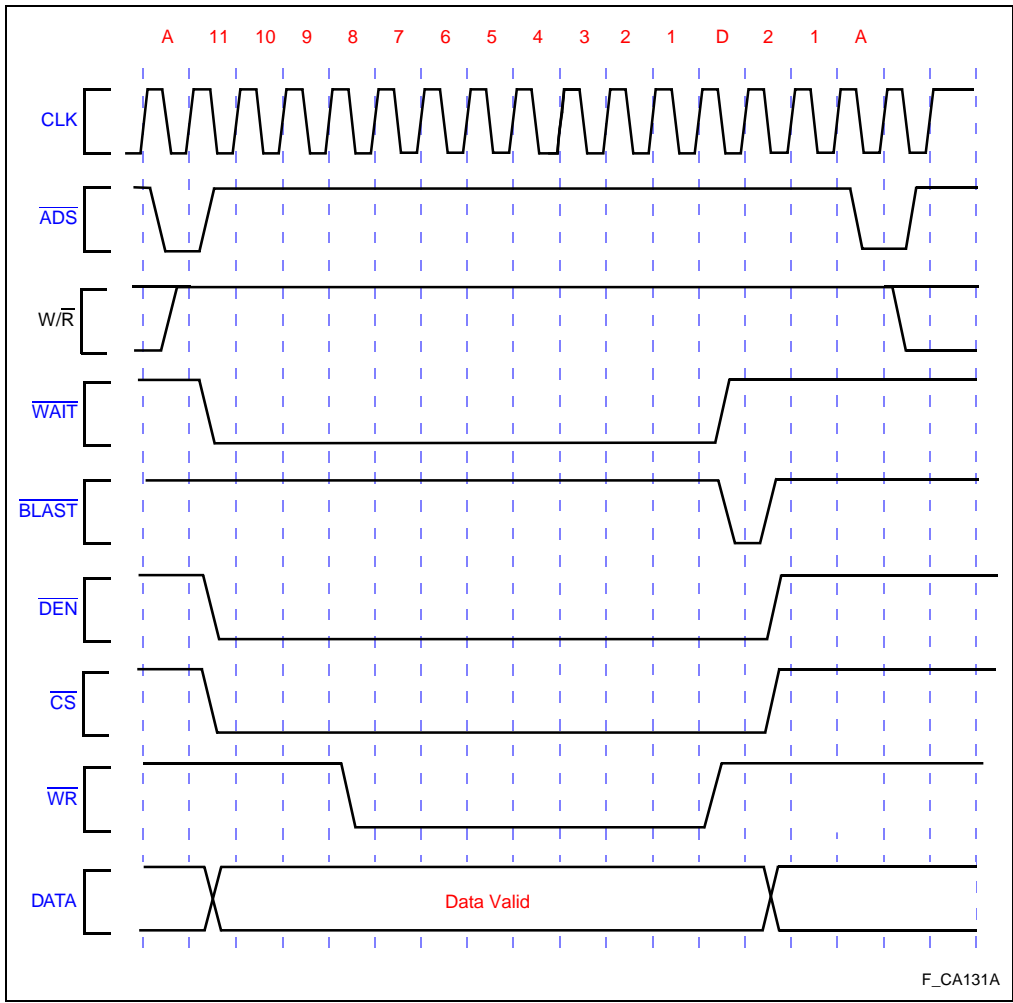


Figure B-31. Write Waveforms



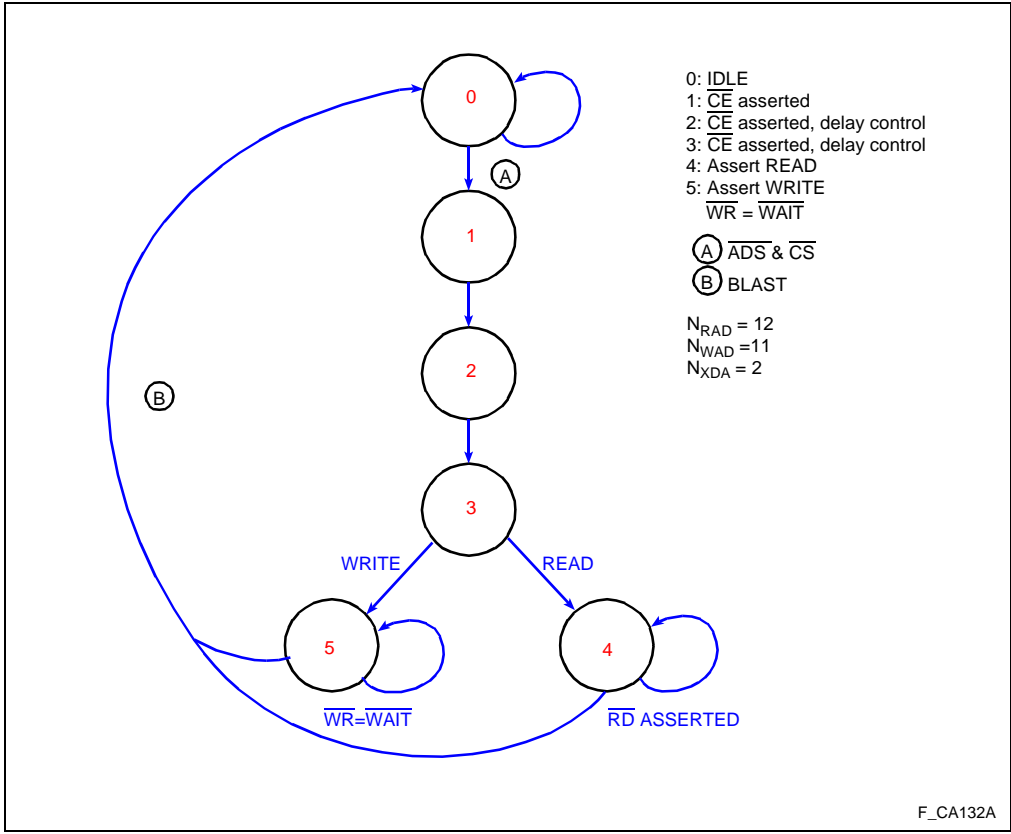


Figure B-32. State Machine Diagram

This pseudo-code example is provided only to describe the state machine diagram shown in Figure B-32. It is not intended for direct use as PLD equations.

```
STATE_0: /*idle */
CE_UART is not asserted;
CE_TC is not asserted;
RD is not asserted;
W/R is not asserted;
IF /* selected */
    ADS & CS;
THEN
    next state is STATE_1;
ELSE
    next state is STATE_0;
STATE_1: /* Enable Selected Chip, Hold Off
Write or Read */
```

**B**

```

STATE_0: /*idle */
CE_UART = A3;
CE_TC = !A3;
RD      is not asserted;
W/R     is not asserted;
the next state is state_2
STATE_2: /* Enable Selected Chip, Hold Off
          Write or Read */
CE_UART = A3;
CE_TC = !A3;
RD      is not asserted;
W/R     is not asserted;
the next state is state_3
STATE_3: /* Enable Selected Chip, Hold Off
          Write or Read */
CE_UART = A3;
CE_TC = !A3;
RD      is not asserted;
W/R     is not asserted;
IF
    !READ                                /* read */
THEN
    next state is STATE_4;
ELSE                                     /* write */
    next state is STATE_5;
STATE_4: /* Read asserted to
          selected peripheral */
CE_UART = A3;
CE_TC = !A3;
RD      is asserted;
W/R     is not asserted;
IF
    BLAST                                /* Done */
THEN
    next state is STATE_0;
ELSE                                     /* write */
    next state is STATE_4;
STATE_5: /* Write asserted to selected peripheral */
CE_UART = A3;
CE_TC = !A3;
RD      is not asserted;
W/R = WAIT
IF
    BLAST                                /* Done */
THEN
    next state is STATE_0;
ELSE                                     /* write */
    next state is STATE_5;

```



C

CONSIDERATIONS FOR  
WRITING PORTABLE CODE

I



# APPENDIX C

## CONSIDERATIONS FOR WRITING PORTABLE CODE

This appendix describes the aspects of the microprocessor that are implementation dependent. The following information is intended as a guide for writing application code that is directly portable to other i960<sup>®</sup> architecture implementations.

### C.1 CORE ARCHITECTURE

All i960 microprocessor family products are based on the core architecture definition. An i960 processor can be thought of as consisting of two parts: the core architecture implementation and implementation-specific features. The core architecture defines the following mechanisms and structure:

- Programming environment: global and local registers, literals, processor state registers, data types, memory addressing modes, etc.
- Implementation-independent instruction set
- Procedure call mechanism
- Mechanism for servicing interrupts and the interrupt and process priority structure
- Mechanism for handling faults and the implementation-independent fault types and subtypes

Implementation-specific features are one or all of:

- Additions to the instruction set beyond the instructions defined by the core architecture.
- Extensions to the register set beyond the global, local and processor-state registers which are defined by the core architecture.
- On-chip program or data memory.
- Integrated peripherals which implement features not defined explicitly by the core architecture.

Code is directly portable (object code compatible) when it does not depend on implementation-specific instructions, mechanisms or registers. The aspects of this microprocessor which are implementation dependent are described below. Those aspects not described below are part of the core architecture.

## C.2 ADDRESS SPACE RESTRICTIONS

Address space properties that are implementation-specific to this microprocessor are described in the subsections that follow.

### C.2.1 Reserved Memory

Addresses in the range FF00 0000H to FFFF FFFFH are reserved by the i960 architecture. Any uses of reserved memory are implementation specific. The i960 Cx processor uses a section of the reserved address space for the initialization boot record; see section 14.2.5, “Initialization Boot Record (IBR)” (pg. 14-5). The initialization boot record may not exist or may be structured differently for other implementations of the i960 architecture. Code which relies on structures in reserved memory is not portable to all i960 processor implementations.

### C.2.2 Internal Data RAM

Internal data RAM — an i960 Cx processor implementation-specific feature — is mapped to the first 1 Kbyte of the processors’ address space (0000H – 03FFH). High performance, supervisor-protected data space and the locations assigned for DMA and interrupt functions are special features which are implemented in internal data RAM. Code which relies on these special features is not directly portable to all i960 processor implementations.

### C.2.3 Instruction Cache

The i960 architecture allows instructions to be cached on-chip in a non-transparent fashion. This means that cache may not detect modification of the program memory by loads, stores or alteration by external agents. Each implementation of the i960 architecture which uses an integrated instruction cache provides a mechanism to purge the cache or some other method that forces consistency between external memory and internal cache.

This mechanism is implementation-dependent. Application code which supports modification of the code space must use this implementation-specific feature and, therefore, is not object code portable to all i960 processor implementations.

The CA has a 1-Kbyte instruction cache; the CF has a 4-Kbyte instruction cache. This instruction cache is purged using the system control (**sysctl**) instruction, which may not be available on other i960 processors.

The CA instruction cache supports locking interrupt procedures into none, half, or all of the cache. The unlocked portion functions as a two-way set associative cache. The CF instruction cache supports locking any code section into half of the cache. The unlocked portion functions as a direct-mapped cache. Refer to section 2.5.5, “Instruction Cache” (pg. 2-13) for a description of cache configuration.





### C.2.4 Data Cache (80960CF Processor Only)

The i960 CF processor's 1 Kbyte direct-mapped data cache can return up to a quad word (128 bits) to the register file in a single clock cycle on a cache hit. In this sense, the data cache has the same bandwidth as the data RAM for cache hits. The data cache has a four-word line size with a separate valid bit for each word in a line. The write policy is write-through and write-allocate.

With respect to data accesses on a region-by-region basis, external memory is configured as either cacheable or non-cacheable. A bit in the memory region table entry defines whether or not data accesses are cacheable. This makes it very easy to partition a system into non-cacheable regions (for I/O or shared data in a multiprocessor system) and cacheable regions (local system memory) with no external hardware logic. To maintain data cache coherency, the i960 CF processor implements a simple single processor coherency mechanism. Also, by software control, the data cache can be globally enabled, globally disabled or globally invalidated. A data access is either:

- explicitly defined as cacheable or non-cacheable—through the memory region table
- implicitly defined as non-cacheable—by the nature of the access; all DMA accesses and atomic accesses (**atmod**, **atadd**) are implicitly defined as non-cacheable data accesses

The data cache indirectly supports unaligned accesses. Micro-flows break unaligned accesses into aligned accesses which are cacheable or non-cacheable according to the same rules as aligned accesses. An unaligned access could be only partially in the data cache and be a combination of hits and misses. The data cache supports both big-endian and little-endian data types.

### C.2.5 Data and Data Structure Alignment

The i960 architecture does not define how to handle loads and stores to non-aligned addresses. Therefore, code which generates non-aligned addresses may not be compatible with all i960 processor implementations. The i960 CA/CF processors automatically handle non-aligned load and store requests in microcode. See section 10.4, "DATA ALIGNMENT" (pg. 10-9).

The address boundaries on which an operand begins can impact processor performance. Operands that span more word boundaries than necessary suffer a cost in speed due to extra bus cycles. In particular, an operand that spans a 16-byte (quad-word) boundary suffers a large cost in speed.

Alignment of architecturally defined data structures in memory is implementation dependent. See section 2.4, "ARCHITECTURE-DEFINED DATA STRUCTURES" (pg. 2-8). Code which relies on specific alignment of data structures in memory is not portable to every i960 processor type.

For each i960 processor type, stack frame alignment is defined according to an **SALIGN** parameter. This alignment boundary is calculated from the relationship  $SALIGN * 16$ . In the i960 Cx processors,  $SALIGN = 1$  so stack frames are aligned on 16-byte boundaries. The low-order N bits of the Frame Pointer are ignored and are always interpreted to be zero. The N parameter is defined by the following expression:  $SALIGN * 16 = 2^N$ . Thus for the i960 Cx processors, N is 4.

**C**

### C.3 RESERVED LOCATIONS IN REGISTERS AND DATA STRUCTURES

Some register and data structure fields are defined as reserved locations. A reserved field may be used by future implementations of the i960 architecture. For portability and compatibility, code should initialize reserved locations. When an implementation uses a reserved location, the implementation-specific feature is activated by a value of 1 in the reserved field. Setting the reserved locations to 0 guarantees that the features are disabled.

### C.4 INSTRUCTION SET

The i960 architecture defines a comprehensive instruction set. Code which uses only the architecturally-defined instruction set is object-level portable to other implementations of the i960 architecture. Some implementations may favor a particular code ordering to optimize performance. This special ordering, however, is never required by an implementation. The following subsections describe the implementation-dependent instruction set properties.

#### C.4.1 Instruction Timing

An objective of the i960 architecture is to allow microarchitectural advances to translate directly into increased performance. The architecture does not restrict parallel or out-of-order instruction execution, nor does it define the time required to execute any instruction or function. Code which depends on instruction execution times, therefore, is not portable to all i960 processor architecture implementations.

#### C.4.2 Implementation-Specific Instructions

Most of the processor's instruction set is defined by the core architecture. Several instructions are specific to the i960 Cx processors. These instructions are either functional extensions to the instruction set or instructions which control implementation-specific functions. CHAPTER 9, INSTRUCTION SET REFERENCE denotes each implementation-specific instruction. These instructions are:

- **eshro** extended shift right ordinal
- **sdma** set up DMA controller
- **udma** update DMA data RAM
- **sysctl** system control

Application code using implementation-specific instructions is not directly portable to the entire i960 processor family.



## C.5 EXTENDED REGISTER SET

The i960 architecture defines a way to address an extended set of 32 registers in addition to the 16 global and 16 local registers. Some or all of these registers may be implemented on a specific i960 processor. Since the use of the extended register set is not defined, code which addresses these registers is not functionally compatible with all implementations of the i960 architecture.

On the i960 Cx processors, three extended registers are implemented as special-function registers, which are designated by bits 5 and 6 of REG format instructions.

## C.6 INITIALIZATION

The i960 architecture does not define an initialization mechanism. The way that an i960-based product is initialized is implementation dependent. Code which accesses locations in initialization data structures is not portable to other i960 processor implementations.

The i960 Cx processors use an initialization boot record (IBR) and a process control block to hold initial configuration and a first instruction pointer.

## C.7 INTERRUPTS

The i960 architecture defines the interrupt servicing mechanism. This includes priority definition, interrupt table structure and interrupt context switching which occurs when an interrupt is serviced. The core architecture does not define the means for requesting interrupts (external pins, software, etc.) or for posting interrupts (i.e., saving pending interrupts).

The method for requesting interrupts depends on the implementation. The i960 Cx processors have an interrupt controller that manages nine external interrupt pins and four internal DMA sources. The organization of these pins and the registers of the interrupt controller are implementation specific. Code which configures the interrupt controller is not directly portable to other i960 implementations.

On the i960 Cx processors, interrupts may also be requested in software with the **sysctl** instruction. This instruction and the software request mechanism are implementation specific.

Posting interrupts is also implementation specific. Different implementations may optimize interrupt posting according to interrupt type and interrupt controller configuration. A pending priorities and pending interrupts field is provided in the interrupt table for interrupt posting. However, the i960 Cx processors post hardware requested interrupts internally in the IPND register instead. Code which requests interrupts by setting bits in the pending priorities and pending interrupts field of the interrupt table is not portable. Also, application code which expects interrupts to be posted in the interrupt table is not object-code portable to all i960-based products.

**C**

The i960 Cx processors do not store a 16-byte resumption record for suspended instructions in the interrupt or fault record. Portable programs must tolerate interrupt stack frames with and without these resumption records.

### C.8 OTHER i960 CA/CF PROCESSOR IMPLEMENTATION-SPECIFIC FEATURES

Subsections that follow describe additional implementation-specific features of the i960 Cx processors. These features do not relate directly to application code portability.

#### C.8.1 Data Control Peripheral Units

The DMA controller, bus controller and interrupt controller are implementation-specific extensions to the core architecture. Operation, setup and control of these units is not a part of the core architecture. Other implementations of the i960 architecture are free to augment or modify such system integration features.

#### C.8.2 Fault Implementation

The architecture defines a subset of fault types and subtypes which apply to all implementations of the architecture. Other fault types and subtypes may be defined by implementations to detect errant conditions which relate to implementation-specific features. For example, the i960 Cx microprocessors provide an operation-unaligned fault for detecting non-aligned memory accesses. Future i960 processor implementations which generate this fault are expected to assign the same fault type and subtype number to the fault.

### C.9 BREAKPOINTS

Breakpoint registers are not defined in the i960 architecture.

#### C.10 $\overline{\text{LOCK}}$ PIN

The  $\overline{\text{LOCK}}$  pin is not defined in the i960 architecture. Bus control logic and protocol associated with this pin may vary among i960 processor implementations.

#### C.10.1 External System Requirements

External system requirements are not defined by the architecture. The external bus,  $\overline{\text{RESET}}$  pin, clock input (and output), power and ground requirements, testability features and I/O characteristics are all specific to the i960 microprocessor implementation.



D

MACHINE-LEVEL  
INSTRUCTION FORMATS

I



## APPENDIX D

# MACHINE-LEVEL INSTRUCTION FORMATS

This appendix describes the encoding format for instructions used by the i960<sup>®</sup> processors. Included is a description of the four instruction formats and how the addressing modes relate to the these formats. Refer also to APPENDIX E, MACHINE LANGUAGE INSTRUCTION REFERENCE.

### D.1 GENERAL INSTRUCTION FORMAT

The i960 architecture defines four basic instruction encoding formats (as shown in Figure D-1): REG, COBR, CTRL and MEM. Each instruction uses one of these formats, which is defined by the instruction's opcode field. All instructions are one word long and begin on word boundaries. MEM format instructions are encoded in one of two sub-formats: MEMA or MEMB. MEMB permits an optional second word to hold a displacement value. The following sections describe each format's instruction word fields.

### D.2 REG FORMAT

REG format is used for operations performed on data contained in global, special function or local registers. Most of the i960 processor family's instructions use this format.

The opcode for the REG instructions is 12 bits long (three hexadecimal digits) and is split between bits 7 through 10 and bits 24 through 31. For example, the **addi** opcode is 591H. Here, 59H is contained in bits 24 through 31; 1H is contained in bits 7 through 10.

*src1* and *src2* fields specify the instruction's source operands. Operands can be global or local registers, special-function registers or literals. Mode bits (M1 for *src1* and M2 for *src2*), special-purpose bits (s1 for *src1* and s2 for *src2*) and the instruction type determine what an operand specifies:

- If a mode bit and its associated special-purpose bit are set to 0, the respective *src1* or *src2* field specifies a global or local register.
- If the mode bit is set to 1 and the special-purpose bit is set to 0, the field specifies a literal in the range of 0 to 31.
- If the mode bit is set to 0 and the special-purpose bit is set to 1, the field specifies a special-function register.

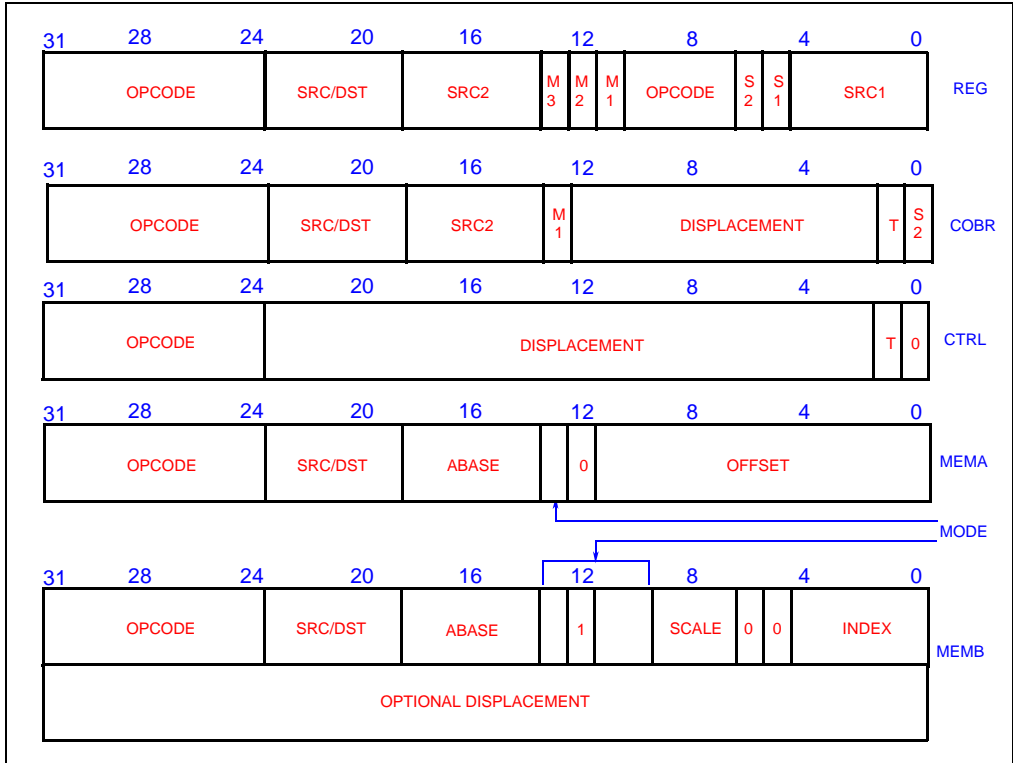


Figure D-1. Instruction Formats

The *src/dst* field can specify a source operand, a destination operand or both, depending on the instruction. Here again, mode bit M3 determines how this field is used. Table D-1 shows this relationship.

Table D-1. Encoding of SRC/DST Field in REG Format

| M3 | SRC/DST                | SRC Only               | DST Only               |
|----|------------------------|------------------------|------------------------|
| 0  | g0 .. g15<br>r0 .. r15 | g0 .. g15<br>r0 .. r15 | g0 .. g15<br>r0 .. r15 |
| 1  | Not Allowed            | Literal                | sf0 .. sf31            |

If M3 is clear, the *src/dst* operand is a global or local register that is encoded as shown in Table D-1. If M3 is set, the *src/dst* operand can be used as a source-only operand that is: (1) a literal or (2) a destination-only operand that is a special function register.





### D.3 COBR FORMAT

The COBR format is used primarily for compare-and-branch instructions. The test-if instructions also use the COBR format. The COBR opcode field is eight bits (two hexadecimal digits).

The *src1* and *src2* fields specify source operands for the instruction. The *src1* field can specify either a global or local register or a literal as determined by mode bit *m1*. The *src2* field can specify a global, local or special function register as determined by special purpose bit *s2*. Complete encodings of these fields is shown in Table E-1., Miscellaneous Instruction Encoding Bits.

The T bit supports 80960Cx processors' branch prediction for conditional instructions. If T is set to 0, the condition being tested is likely to be true; if set to 1, the condition is likely to be false.

The displacement field contains a signed two's complement number that specifies a word displacement. The processor uses this value to compute the address of a target instruction to which the processor goes as a result of a comparison. The displacement field's value can range from  $-2^{10}$  to  $2^{10} - 1$ . To determine the target instruction's IP, the processor converts the displacement value to a byte displacement (i.e., multiplies the value by 4). It then adds the resulting byte displacement to the IP of the current instruction.

For the test-if instructions, only the *src1* field is used. Here, this field specifies a destination global or local register; M1 is ignored.

### D.4 CTRL FORMAT

The CTRL format is used for instructions that branch to a new IP, including the branch, branch-if, **bal** and **call** instructions; **ret** also uses this format. The CTRL opcode field is eight bits (two hexadecimal digits).

A branch target address is specified with the displacement field in the same manner as COBR format instructions. The displacement field specifies a word displacement as a signed, two's complement number in the range  $-2^{21}$  to  $2^{21} - 1$ . The processor ignores the **ret** instruction's displacement field.

The T bit performs the same prediction function for CTRL instructions as it does for COBR instructions.

### D.5 MEM FORMAT

The MEM format is used for instructions that require a memory address to be computed. These instructions include the load, store and **lda** instructions. Also, the extended versions of the branch, branch-and-link and call instructions (**bx**, **balx** and **callx**) use this format.

## MACHINE-LEVEL INSTRUCTION FORMATS

The two MEM-format encodings are MEMA and MEMB. MEMB can optionally add a 32-bit displacement (contained in a second word) to the instruction. Bit 12 of the instruction's first word determines whether MEMA (clear) or MEMB (set) is used.

The opcode field is eight bits long for either encoding. The *src/dst* field specifies a global or local register. For load instructions, *src/dst* specifies the destination register for a word loaded into the processor from memory or, for operands larger than one word, the first of successive destination registers. For store instructions, this field specifies the register or group of registers that contain the source operand to be stored in memory.

The mode field determines the address mode used for the instruction. Table D-2 summarizes the addressing modes for the two MEM-format encodings. Fields used in these addressing modes are described in the following sections.

**Table D-2. Addressing Modes for MEM Format Instructions**

| Format | Mode | Address Computation                                   |
|--------|------|---|
| MEMA   | 00   | offset  |
|        | 10   | (abase) + offset                                      |
| MEMB   | 0100 | (abase)   |
|        | 0101 | (IP) + displacement + 8                               |
|        | 0110 | reserved  |
|        | 0111 | (abase) + (index) * 2 <sup>scale</sup>                |
|        | 1100 | displacement  |
|        | 1101 | (abase) + displacement                                |
|        | 1110 | (index) * 2 <sup>scale</sup> + displacement           |
|        | 1111 | (abase) + (index) * 2 <sup>scale</sup> + displacement |

**NOTE:**

In these address computations, a field in parentheses, e.g., (abase), indicates that the value in the specified register is used in the computation.

Usage of a reserved encoding causes generation of an invalid-opcode fault.

### D.5.1 MEMA Format Addressing

The MEMA format provides two addressing modes:

- absolute offset
- register indirect with offset

The *offset* field specifies an unsigned byte offset from 0 to 4096. The *abase* field specifies a global or local register that contains an address in memory.



For the absolute-offset addressing mode (*mode* = 00), the processor interprets the *offset* field as an offset from byte 0 of the current process address space; the *abase* field is ignored. Using this addressing mode along with the **lda** instruction allows a constant in the range 0 to 4096 to be loaded into a register.

For the register-indirect-with-offset addressing mode (*mode* = 10), *offset* field value is added to the address in the *abase* register. Setting the offset value to zero creates a register indirect addressing mode; however, this operation can generally be carried out faster by using the MEMB version of this addressing mode.

**D.5.2 MEMB Format Addressing**

The MEMB format provides the following seven addressing modes:

- absolute displacement
- register indirect with displacement
- register indirect with index and displacement
- IP with displacement
- register indirect
- register indirect with displacement
- index with displacement

The *abase* and *index* fields specify local or global registers, the contents of which are used in address computation. When the index field is used in an addressing mode, the processor automatically scales the index register value by the amount specified in the scale field. Table D-3 gives the encoding of the scale field. The optional displacement field is contained in the word following the instruction word. The displacement is a 32-bit signed two's complement value.

**Table D-3. Encoding of Scale Field**

| Scale      | Scale Factor (Multiplier) |
|------------|---------------------------|
| 000        | 1                         |
| 001        | 2                         |
| 010        | 4                         |
| 011        | 8                         |
| 100        | 16                        |
| 101 to 111 | Reserved                  |

**NOTE:**  
Usage of a reserved encoding causes generation of an invalid-opcode fault.

For the IP with displacement mode, the value of the displacement field plus eight is added to the address of the current instruction.







E

MACHINE LANGUAGE  
INSTRUCTION REFERENCE

I



# APPENDIX E

## MACHINE LANGUAGE INSTRUCTION REFERENCE

### E.1 INSTRUCTION REFERENCE BY OPCODE

This section lists the instruction encoding for each i960<sup>®</sup> microprocessor instruction. Instructions are grouped by instruction format and listed by opcode within each format.

**Table E-1. Miscellaneous Instruction Encoding Bits**

| M3                                 | M2 | M1 | S2 | S1 | T | Description   |
|------------------------------------|----|----|----|----|---|---|
| <b>REG Format</b>                  |    |    |    |    |   |   |
| x                                  | x  | 0  | x  | 0  | — | <i>src1</i> is a global or local register   |
| x                                  | x  | 1  | x  | 0  | — | <i>src1</i> is a literal  |
| x                                  | x  | 0  | x  | 1  | — | <i>src1</i> is a special function register  |
| x                                  | x  | 1  | x  | 1  | — | reserved  |
| x                                  | 0  | x  | 0  | x  | — | <i>src2</i> is a global or local register   |
| x                                  | 1  | x  | 0  | x  | — | <i>src2</i> is a literal  |
| x                                  | 0  | x  | 1  | x  | — | <i>src2</i> is a special function register  |
| x                                  | 1  | x  | 1  | x  | — | reserved  |
| 0                                  | x  | x  | x  | x  | — | <i>src/dst</i> is a global or local register  |
| 1                                  | x  | x  | x  | x  | — | <i>src/dst</i> is a literal when used as a source or a special function register when used as a destination. M3 may not be 1 when <i>src/dst</i> is used both as a source and destination in an instruction ( <b>atmod</b> , <b>modify</b> , <b>extract</b> , <b>modpc</b> ). |
| <b>COBR Format</b>                 |    |    |    |    |   |   |
| —                                  | —  | 0  | 0  | —  | x | <i>src1 src2</i> and <i>dst</i> are global or local registers   |
| —                                  | —  | 1  | 0  | —  | x | <i>src1</i> is a literal, <i>src2</i> and <i>dst</i> are global or local registers  |
| —                                  | —  | 0  | 1  | —  | x | <i>src1</i> is a global or local register, <i>src2</i> and <i>dst</i> are special function registers  |
| —                                  | —  | 1  | 1  | —  | 0 | <i>src1</i> is a literal, <i>src2</i> and <i>dst</i> are special function registers   |
| <b>COBR Format and CTRL Format</b> |    |    |    |    |   |   |
| —                                  | —  | x  | —  | x  | 0 | Outcome of conditional test is predicted to be true.  |
| —                                  | —  | x  | —  | x  | 1 | Outcome of conditional test is predicted to be false.   |

Table E-2. REG Format Instruction Encodings (Sheet 1 of 2)

| Opcode | Mnemonic        | Opcode (11 - 4) |      |  | Mode |    |    | Opcode (3-0) |    | Special Flags |          | src1 |
|--------|-----------------|-----------------|------|--|------|----|----|--------------|----|---------------|----------|------|
|        |                 | src/dst         | src2 |  | 13   | 12 | 11 | 10..... 7    | 6  | 5             | 4..... 0 |      |
| 58:0   | <b>notbit</b>   | dst             | src  |  | M3   | M2 | M1 | 0000         | S2 | S1            | bitpos   |      |
| 58:1   | <b>and</b>      | dst             | src2 |  | M3   | M2 | M1 | 0001         | S2 | S1            | src1     |      |
| 58:2   | <b>andnot</b>   | dst             | src2 |  | M3   | M2 | M1 | 0010         | S2 | S1            | src1     |      |
| 58:3   | <b>setbit</b>   | dst             | src  |  | M3   | M2 | M1 | 0011         | S2 | S1            | bitpos   |      |
| 58:4   | <b>notand</b>   | dst             | src2 |  | M3   | M2 | M1 | 0100         | S2 | S1            | src1     |      |
| 58:6   | <b>xor</b>      | dst             | src2 |  | M3   | M2 | M1 | 0110         | S2 | S1            | src1     |      |
| 58:7   | <b>or</b>       | dst             | src2 |  | M3   | M2 | M1 | 0111         | S2 | S1            | src1     |      |
| 58:8   | <b>nor</b>      | dst             | src2 |  | M3   | M2 | M1 | 1000         | S2 | S1            | src1     |      |
| 58:9   | <b>xnor</b>     | dst             | src2 |  | M3   | M2 | M1 | 1001         | S2 | S1            | src1     |      |
| 58:A   | <b>not</b>      | dst             |      |  | M3   | M2 | M1 | 1010         | S2 | S1            | src      |      |
| 58:B   | <b>ornot</b>    | dst             | src2 |  | M3   | M2 | M1 | 1011         | S2 | S1            | src1     |      |
| 58:C   | <b>clrbt</b>    | dst             | src  |  | M3   | M2 | M1 | 1100         | S2 | S1            | bitpos   |      |
| 58:D   | <b>notor</b>    | dst             | src2 |  | M3   | M2 | M1 | 1101         | S2 | S1            | src1     |      |
| 58:E   | <b>nand</b>     | dst             | src2 |  | M3   | M2 | M1 | 1110         | S2 | S1            | src1     |      |
| 58:F   | <b>alterbit</b> | dst             | src  |  | M3   | M2 | M1 | 1111         | S2 | S1            | bitpos   |      |
| 59:0   | <b>addo</b>     | dst             | src2 |  | M3   | M2 | M1 | 0000         | S2 | S1            | src1     |      |
| 59:1   | <b>addi</b>     | dst             | src2 |  | M3   | M2 | M1 | 0001         | S2 | S1            | src1     |      |
| 59:2   | <b>subo</b>     | dst             | src2 |  | M3   | M2 | M1 | 0010         | S2 | S1            | src1     |      |
| 59:3   | <b>subi</b>     | dst             | src2 |  | M3   | M2 | M1 | 0011         | S2 | S1            | src1     |      |
| 59:8   | <b>shro</b>     | dst             | src  |  | M3   | M2 | M1 | 1000         | S2 | S1            | len      |      |
| 59:A   | <b>shrdi</b>    | dst             | src  |  | M3   | M2 | M1 | 1010         | S2 | S1            | len      |      |
| 59:B   | <b>shri</b>     | dst             | src  |  | M3   | M2 | M1 | 1011         | S2 | S1            | len      |      |
| 59:C   | <b>shlo</b>     | dst             | src  |  | M3   | M2 | M1 | 1100         | S2 | S1            | len      |      |
| 59:D   | <b>rotate</b>   | dst             | src  |  | M3   | M2 | M1 | 1101         | S2 | S1            | len      |      |
| 59:E   | <b>shli</b>     | dst             | src  |  | M3   | M2 | M1 | 1110         | S2 | S1            | len      |      |
| 5A:0   | <b>cmpo</b>     |                 | src2 |  | M3   | M2 | M1 | 0000         | S2 | S1            | src1     |      |
| 5A:1   | <b>cmpi</b>     |                 | src2 |  | M3   | M2 | M1 | 0001         | S2 | S1            | src1     |      |
| 5A:2   | <b>concmpo</b>  |                 | src2 |  | M3   | M2 | M1 | 0010         | S2 | S1            | src1     |      |
| 5A:3   | <b>concmpi</b>  |                 | src2 |  | M3   | M2 | M1 | 0011         | S2 | S1            | src1     |      |
| 5A:4   | <b>cmpinco</b>  | dst             | src2 |  | M3   | M2 | M1 | 0100         | S2 | S1            | src1     |      |
| 5A:5   | <b>cmpinci</b>  | dst             | src2 |  | M3   | M2 | M1 | 0101         | S2 | S1            | src1     |      |
| 5A:6   | <b>cmpdeco</b>  | dst             | src2 |  | M3   | M2 | M1 | 0110         | S2 | S1            | src1     |      |



Table E-2. REG Format Instruction Encodings (Sheet 2 of 2)

| Opcode | Mnemonic        | Opcode (11 - 4) |                | src/dst     |    |    | Mode |            |    | Opcode (3-0) |               |    | Special Flags |      | src1 |  |
|--------|-----------------|-----------------|----------------|-------------|----|----|------|------------|----|--------------|---------------|----|---------------|------|------|--|
|        |                 | 31.....24       | 23.....19      | 18.. 14     | 13 | 12 | 11   | 10 ..... 7 | 6  | 5            | 4 ..... 0     | S2 | S1            | src1 |      |  |
| 5A:7   | <b>cmpdeci</b>  | 0101 1010       | <i>dst</i>     | <i>src2</i> | M3 | M2 | M1   | 0111       | S2 | S1           | <i>src1</i>   |    |               |      |      |  |
| 5A:C   | <b>scanbyte</b> | 0101 1010       |                | <i>src2</i> | M3 | M2 | M1   | 1100       | S2 | S1           | <i>src1</i>   |    |               |      |      |  |
| 5A:E   | <b>chkbit</b>   | 0101 1010       |                | <i>src</i>  | M3 | M2 | M1   | 1110       | S2 | S1           | <i>bitpos</i> |    |               |      |      |  |
| 5B:0   | <b>addc</b>     | 0101 1011       | <i>dst</i>     | <i>src2</i> | M3 | M2 | M1   | 0000       | S2 | S1           | <i>src1</i>   |    |               |      |      |  |
| 5B:2   | <b>subc</b>     | 0101 1011       | <i>dst</i>     | <i>src2</i> | M3 | M2 | M1   | 0010       | S2 | S1           | <i>src1</i>   |    |               |      |      |  |
| 5C:C   | <b>mov</b>      | 0101 1100       | <i>dst</i>     |             | M3 | M2 | M1   | 1100       | S2 | S1           | <i>src</i>    |    |               |      |      |  |
| 5D:8   | <b>eshro</b>    | 0101 1101       | <i>dst</i>     | <i>src2</i> | M3 | M2 | M1   | 1000       | S2 | S1           | <i>src1</i>   |    |               |      |      |  |
| 5D:C   | <b>movl</b>     | 0101 1101       | <i>dst</i>     |             | M3 | M2 | M1   | 1100       | S2 | S1           | <i>src</i>    |    |               |      |      |  |
| 5E:C   | <b>movt</b>     | 0101 1110       | <i>dst</i>     |             | M3 | M2 | M1   | 1100       | S2 | S1           | <i>src</i>    |    |               |      |      |  |
| 5F:C   | <b>movq</b>     | 0101 1111       | <i>dst</i>     |             | M3 | M2 | M1   | 1100       | S2 | S1           | <i>src</i>    |    |               |      |      |  |
| 63:0   | <b>sdma</b>     | 0110 0011       | <i>src3</i>    | <i>src2</i> | M3 | M2 | M1   | 0000       | S2 | S1           | <i>src1</i>   |    |               |      |      |  |
| 63:1   | <b>udma</b>     | 0110 0011       |                |             |    |    |      | 0001       |    |              |               |    |               |      |      |  |
| 64:0   | <b>spanbit</b>  | 0110 0100       | <i>dst</i>     |             | M3 | M2 | M1   | 0000       | S2 | S1           | <i>src</i>    |    |               |      |      |  |
| 64:1   | <b>scanbit</b>  | 0110 0100       | <i>dst</i>     |             | M3 | M2 | M1   | 0001       | S2 | S1           | <i>src</i>    |    |               |      |      |  |
| 64:5   | <b>modac</b>    | 0110 0100       | <i>mask</i>    | <i>src</i>  | M3 | M2 | M1   | 0101       | S2 | S1           | <i>dst</i>    |    |               |      |      |  |
| 65:0   | <b>modify</b>   | 0110 0101       | <i>src/dst</i> | <i>src</i>  | M3 | M2 | M1   | 0000       | S2 | S1           | <i>mask</i>   |    |               |      |      |  |
| 65:1   | <b>extract</b>  | 0110 0101       | <i>src/dst</i> | <i>len</i>  | M3 | M2 | M1   | 0001       | S2 | S1           | <i>bitpos</i> |    |               |      |      |  |
| 65:4   | <b>modtc</b>    | 0110 0101       | <i>mask</i>    | <i>src</i>  | M3 | M2 | M1   | 0100       | S2 | S1           | <i>dst</i>    |    |               |      |      |  |
| 65:5   | <b>modpc</b>    | 0110 0101       | <i>src/dst</i> | <i>mask</i> | M3 | M2 | M1   | 0101       | S2 | S1           | <i>src</i>    |    |               |      |      |  |
| 65:9   | <b>sysctl</b>   | 0110 0101       | <i>src3</i>    | <i>src2</i> | M3 | M2 | M1   | 1001       | S2 | S1           | <i>src1</i>   |    |               |      |      |  |
| 66:0   | <b>calls</b>    | 0110 0110       |                |             | M3 | M2 | M1   | 0000       | S2 | S1           | <i>src</i>    |    |               |      |      |  |
| 66:B   | <b>mark</b>     | 0110 0110       |                |             | M3 | M2 | M1   | 1011       | S2 | S1           |               |    |               |      |      |  |
| 66:C   | <b>fmark</b>    | 0110 0110       |                |             | M3 | M2 | M1   | 1100       | S2 | S1           |               |    |               |      |      |  |
| 66:D   | <b>flushreg</b> | 0110 0110       |                |             | M3 | M2 | M1   | 1101       | S2 | S1           |               |    |               |      |      |  |
| 66:F   | <b>syncf</b>    | 0110 0110       |                |             | M3 | M2 | M1   | 1111       | S2 | S1           |               |    |               |      |      |  |
| 67:0   | <b>emul</b>     | 0110 0111       | <i>dst</i>     | <i>src2</i> | M3 | M2 | M1   | 0000       | S2 | S1           | <i>src1</i>   |    |               |      |      |  |
| 67:1   | <b>ediv</b>     | 0110 0111       | <i>dst</i>     | <i>src2</i> | M3 | M2 | M1   | 0001       | S2 | S1           | <i>src1</i>   |    |               |      |      |  |
| 70:1   | <b>mulo</b>     | 0111 0000       | <i>dst</i>     | <i>src2</i> | M3 | M2 | M1   | 0001       | S2 | S1           | <i>src1</i>   |    |               |      |      |  |
| 70:8   | <b>remo</b>     | 0111 0000       | <i>dst</i>     | <i>src2</i> | M3 | M2 | M1   | 1000       | S2 | S1           | <i>src1</i>   |    |               |      |      |  |
| 70:B   | <b>divo</b>     | 0111 0000       | <i>dst</i>     | <i>src2</i> | M3 | M2 | M1   | 1011       | S2 | S1           | <i>src1</i>   |    |               |      |      |  |
| 74:1   | <b>muli</b>     | 0111 0100       | <i>dst</i>     | <i>src2</i> | M3 | M2 | M1   | 0001       | S2 | S1           | <i>src1</i>   |    |               |      |      |  |
| 74:8   | <b>remi</b>     | 0111 0100       | <i>dst</i>     | <i>src2</i> | M3 | M2 | M1   | 1000       | S2 | S1           | <i>src1</i>   |    |               |      |      |  |
| 74:9   | <b>modi</b>     | 0111 0100       | <i>dst</i>     | <i>src2</i> | M3 | M2 | M1   | 1001       | S2 | S1           | <i>src1</i>   |    |               |      |      |  |
| 74:B   | <b>divi</b>     | 0111 0100       | <i>dst</i>     | <i>src2</i> | M3 | M2 | M1   | 1011       | S2 | S1           | <i>src1</i>   |    |               |      |      |  |



Table E-3. COBR Format Instruction Encodings

| Opcode | Mnemonic       | Opcode      | src1          | src2        | M  | Displacement | T | S2 |
|--------|----------------|-------------|---------------|-------------|----|--------------|---|----|
|        |                | 31 ..... 24 | 2319          | 18... 14    | 13 | 12 ..... 2   | 1 | 0  |
| 20     | <b>testno</b>  | 0010 0000   | <i>dst</i>    |             | M1 |              | T | S2 |
| 21     | <b>testg</b>   | 0010 0001   | <i>dst</i>    |             | M1 |              | T | S2 |
| 22     | <b>teste</b>   | 0010 0010   | <i>dst</i>    |             | M1 |              | T | S2 |
| 23     | <b>testge</b>  | 0010 0011   | <i>dst</i>    |             | M1 |              | T | S2 |
| 24     | <b>testl</b>   | 0010 0100   | <i>dst</i>    |             | M1 |              | T | S2 |
| 25     | <b>testne</b>  | 0010 0101   | <i>dst</i>    |             | M1 |              | T | S2 |
| 26     | <b>testle</b>  | 0010 0110   | <i>dst</i>    |             | M1 |              | T | S2 |
| 27     | <b>testo</b>   | 0010 0111   | <i>dst</i>    |             | M1 |              | T | S2 |
| 30     | <b>bbc</b>     | 0011 0000   | <i>bitpos</i> | <i>src</i>  | M1 | <i>targ</i>  | T | S2 |
| 31     | <b>cmpobg</b>  | 0011 0001   | <i>src1</i>   | <i>src2</i> | M1 | <i>targ</i>  | T | S2 |
| 32     | <b>cmpobe</b>  | 0011 0010   | <i>src1</i>   | <i>src2</i> | M1 | <i>targ</i>  | T | S2 |
| 33     | <b>cmpobge</b> | 0011 0011   | <i>src1</i>   | <i>src2</i> | M1 | <i>targ</i>  | T | S2 |
| 34     | <b>cmpobl</b>  | 0011 0100   | <i>src1</i>   | <i>src2</i> | M1 | <i>targ</i>  | T | S2 |
| 35     | <b>cmpobne</b> | 0011 0101   | <i>src1</i>   | <i>src2</i> | M1 | <i>targ</i>  | T | S2 |
| 36     | <b>cmpoble</b> | 0011 0110   | <i>src1</i>   | <i>src2</i> | M1 | <i>targ</i>  | T | S2 |
| 37     | <b>bbs</b>     | 0011 0111   | <i>bitpos</i> | <i>src</i>  | M1 | <i>targ</i>  | T | S2 |
| 38     | <b>cmpibno</b> | 0011 1000   | <i>src1</i>   | <i>src2</i> | M1 | <i>targ</i>  | T | S2 |
| 39     | <b>cmpibg</b>  | 0011 1001   | <i>src1</i>   | <i>src2</i> | M1 | <i>targ</i>  | T | S2 |
| 3A     | <b>cmpibe</b>  | 0011 1010   | <i>src1</i>   | <i>src2</i> | M1 | <i>targ</i>  | T | S2 |
| 3B     | <b>cmpibge</b> | 0011 1011   | <i>src1</i>   | <i>src2</i> | M1 | <i>targ</i>  | T | S2 |
| 3C     | <b>cmpibl</b>  | 0011 1100   | <i>src1</i>   | <i>src2</i> | M1 | <i>targ</i>  | T | S2 |
| 3D     | <b>cmpibne</b> | 0011 1101   | <i>src1</i>   | <i>src2</i> | M1 | <i>targ</i>  | T | S2 |
| 3E     | <b>cmpible</b> | 0011 1110   | <i>src1</i>   | <i>src2</i> | M1 | <i>targ</i>  | T | S2 |
| 3F     | <b>cmpibo</b>  | 0011 1111   | <i>src1</i>   | <i>src2</i> | M1 | <i>targ</i>  | T | S2 |



Table E-4. CTRL Format Instruction Encodings

| Opcode | Mnemonic       | Opcode    | Displacement | T | 0 |
|--------|----------------|-----------|--------------|---|---|
|        |                | 31.....24 | 23.....2     |   |   |
| 08     | <b>b</b>       | 0000 1000 | <i>targ</i>  | T | 0 |
| 09     | <b>call</b>    | 0000 1001 | <i>targ</i>  | T | 0 |
| 0A     | <b>ret</b>     | 0000 1010 |              | T | 0 |
| 0B     | <b>bal</b>     | 0000 1011 | <i>targ</i>  | T | 0 |
| 10     | <b>bno</b>     | 0001 0000 | <i>targ</i>  | T | 0 |
| 11     | <b>bg</b>      | 0001 0001 | <i>targ</i>  | T | 0 |
| 12     | <b>be</b>      | 0001 0010 | <i>targ</i>  | T | 0 |
| 13     | <b>bge</b>     | 0001 0011 | <i>targ</i>  | T | 0 |
| 14     | <b>bl</b>      | 0001 0100 | <i>targ</i>  | T | 0 |
| 15     | <b>bne</b>     | 0001 0101 | <i>targ</i>  | T | 0 |
| 16     | <b>ble</b>     | 0001 0110 | <i>targ</i>  | T | 0 |
| 17     | <b>bo</b>      | 0001 0111 | <i>targ</i>  | T | 0 |
| 18     | <b>faultno</b> | 0001 1000 |              | T | 0 |
| 19     | <b>faultg</b>  | 0001 1001 |              | T | 0 |
| 1A     | <b>faulte</b>  | 0001 1010 |              | T | 0 |
| 1B     | <b>faultge</b> | 0001 1011 |              | T | 0 |
| 1C     | <b>faultl</b>  | 0001 1100 |              | T | 0 |
| 1D     | <b>faultne</b> | 0001 1101 |              | T | 0 |
| 1E     | <b>faultle</b> | 0001 1110 |              | T | 0 |
| 1F     | <b>faulto</b>  | 0001 1111 |              | T | 0 |



**Table E-5. MEM Format Instruction Encodings**

|                     |                |              |                       |               |           |              |
|---------------------|----------------|--------------|-----------------------|---------------|-----------|--------------|
| 31..... 24          | 23.. .19       | 18..... 14   | 1312                  | 110           |           |              |
| <b>Opcode</b>       | <b>src/dst</b> | <b>ABASE</b> | <b>Mode</b>           | <b>Offset</b> |           |              |
| 3124                | 23.. .19       | 18..... 14   | 13 .....12. 11.....10 | 97            | 65        | 40           |
| <b>Opcode</b>       | <b>src/dst</b> | <b>ABASE</b> | <b>Mode</b>           | <b>Scale</b>  | <b>00</b> | <b>Index</b> |
| <b>Displacement</b> |                |              |                       |               |           |              |

**Effective Address**

|                     |   |        |     |             |   |   |        |   |              |    |             |
|---------------------|---|--------|-----|-------------|---|---|--------|---|--------------|----|-------------|
| <i>efa</i> =        | offset  | Opcode | dst |             | 0 | 0 | offset |   |              |    |             |
|                     | offset( <i>reg</i> )                                      | Opcode | dst | <i>reg</i>  | 1 | 0 | offset |   |              |    |             |
|                     | ( <i>reg</i> )  | Opcode | dst | <i>reg</i>  | 0 | 1 | 0      | 0 | 00           |    |             |
|                     | <i>disp</i> + 8 (IP)                                      | Opcode | dst |             | 0 | 1 | 0      | 1 | 00           |    |             |
| <i>displacement</i> |   |        |     |             |   |   |        |   |              |    |             |
|                     | ( <i>reg1</i> )[ <i>reg2</i> * <i>scale</i> ]             | Opcode | dst | <i>reg1</i> | 0 | 1 | 1      | 1 | <i>scale</i> | 00 | <i>reg2</i> |
|                     | <i>disp</i>   | Opcode | dst |             | 1 | 1 | 0      | 0 | 00           |    |             |
| <i>displacement</i> |   |        |     |             |   |   |        |   |              |    |             |
|                     | <i>disp</i> ( <i>reg</i> )                                | Opcode | dst | <i>reg</i>  | 1 | 1 | 0      | 1 | 00           |    |             |
| <i>displacement</i> |   |        |     |             |   |   |        |   |              |    |             |
|                     | <i>disp</i> [ <i>reg</i> * <i>scale</i> ]                 | Opcode | dst |             | 1 | 1 | 1      | 0 | <i>scale</i> | 00 | <i>reg</i>  |
| <i>displacement</i> |   |        |     |             |   |   |        |   |              |    |             |
|                     | <i>disp</i> ( <i>reg1</i> )[ <i>reg2</i> * <i>scale</i> ] | Opcode | dst | <i>reg1</i> | 1 | 1 | 1      | 1 | <i>scale</i> | 00 | <i>reg2</i> |
| <i>displacement</i> |   |        |     |             |   |   |        |   |              |    |             |

| Opcode | Mnemonic     | Opcode | Mnemonic    |
|--------|--------------|--------|-------------|
| 80     | <b>ldob</b>  | 98     | <b>ldl</b>  |
| 82     | <b>stob</b>  | 9A     | <b>stl</b>  |
| 84     | <b>bx</b>    | A0     | <b>ldt</b>  |
| 85     | <b>balx</b>  | A2     | <b>stt</b>  |
| 86     | <b>callx</b> | B0     | <b>ldq</b>  |
| 88     | <b>ldos</b>  | B2     | <b>stq</b>  |
| 8A     | <b>stos</b>  | C0     | <b>ldib</b> |
| 8C     | <b>lda</b>   | C2     | <b>stib</b> |
| 90     | <b>ld</b>    | C8     | <b>ldis</b> |
| 92     | <b>st</b>    | CA     | <b>stis</b> |





F

# REGISTER AND DATA STRUCTURES

I



# APPENDIX F REGISTER AND DATA STRUCTURES



This appendix is a compilation of all register and data structure figures described throughout the manual. Section F.1, “Data Structures” (pg. F-2) contains diagrams of the memory-resident data structures, listed in order of importance. Section F.2, “Registers” (pg. F-10) lists all registers alphabetically. Following each figure is a reference that indicates the section that discusses the figure.

| Fig. | Register / Data Structure                                    | Where defined in the manual   | Page |
|------|--|---|------|
| F-1  | Control Table  | Section 2.3, “CONTROL REGISTERS” (pg. 2-6)                                      | F-2  |
| F-2  | Fault Record   | Section 7.5.1, “Fault Record Data” (pg. 7-6)                                    | F-3  |
| F-3  | Fault Table and Fault Table Entries                          | Section 7.3, “FAULT TABLE” (pg. 7-4)  | F-4  |
| F-4  | Initial Memory Image (IMI) and Process Control Block (PRCB)  | Section 14.2.5, “Initialization Boot Record (IBR)” (pg. 14-5)                   | F-5  |
| F-5  | Storage of an Interrupt Record on the Interrupt Stack        | Section 6.7, “INTERRUPT STACK AND INTERRUPT RECORD” (pg. 6-9)                   | F-6  |
| F-6  | Interrupt Table  | Section 6.4, “INTERRUPT TABLE” (pg. 6-3)  | F-7  |
| F-7  | Procedure Stack Structure and Local Registers                | Section 5.2.1, “Local Registers and the Procedure Stack” (pg. 5-2)              | F-8  |
| F-8  | System Procedure Table                                       | Section 5.5.1.1, “Procedure Entries” (pg. 5-14)                                 | F-9  |
| F-9  | Arithmetic Controls Register (AC)                            | Section 2.6.2, “Arithmetic Controls (AC) Register” (pg. 2-15)                   | F-10 |
| F-10 | Bus Configuration Register (BCON)                            | Section 10.3.2, “Bus Configuration Register (BCON)” (pg. 10-8)                  | F-10 |
| F-11 | Data Address Breakpoint Registers                            | Section 8.2.7, “Breakpoint Trace” (pg. 8-5)                                     | F-11 |
| F-12 | DMA Command Register (DMAC)                                  | Section 13.10.1, “DMA Command Register (DMAC)” (pg. 13-21)                      | F-11 |
| F-13 | DMA Control Word   | Section 13.10.3, “DMA Control Word” (pg. 13-25)                                 | F-12 |
| F-14 | Hardware Breakpoint Control Register (BPCON)                 | Section 8.2.7, “Breakpoint Trace” (pg. 8-5)                                     | F-13 |
| F-15 | Instruction Address Breakpoint Registers (IPB0 - IPB1)       | Section 8.2.7, “Breakpoint Trace” (pg. 8-5)                                     | F-13 |
| F-16 | Interrupt Control (ICON) Register                            | Section 12.3.4, “Interrupt Control Register (ICON)” (pg. 12-11)                 | F-14 |
| F-17 | Interrupt Map (IMAP0 - IMAP2) Registers                      | Section 12.3.5, “Interrupt Mapping Registers (IMAP0-IMAP2)” (pg. 12-12)         | F-15 |
| F-18 | Interrupt Mask (IMSK) and Interrupt Pending (IPND) Registers | Section 12.3.6, “Interrupt Mask and Pending Registers (IMSK, IPND)” (pg. 12-14) | F-16 |
| F-19 | Memory Region Configuration Register (MCON 0-15)             | Section 10.3.1, “Memory Region Configuration Registers (MCON 0-15)” (pg. 10-6)  | F-17 |
| F-20 | Previous Frame Pointer Register (PFP) (r0)                   | Section 5.8, “RETURNS” (pg. 5-16)   | F-18 |
| F-21 | Process Controls (PC) Register                               | Section 2.6.3.1, “Initializing and Modifying the PC Register” (pg. 2-19)        | F-18 |
| F-22 | Trace Controls (TC) Register                                 | Section 8.1.1, “Trace Controls (TC) Register” (pg. 8-2)                         | F-19 |
| F-23 | Process Control Block Configuration Words                    | Section 14.3, “REQUIRED DATA STRUCTURES” (pg. 14-11)                            | F-20 |



F.1 Data Structures

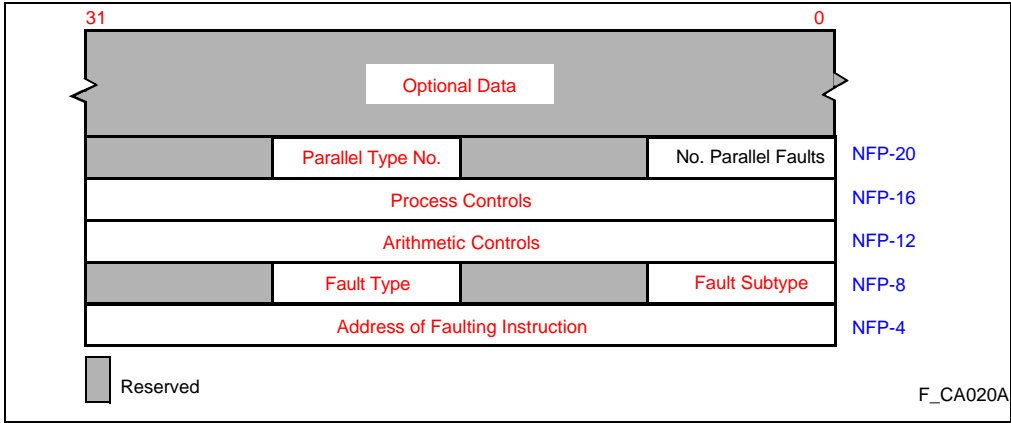
|   |     |
|---|-----|
| 31                                      | 0   |
| IP Breakpoint 0 (IPB0)                  | 0H  |
| IP Breakpoint 1 (IPB1)                  | 4H  |
| Data Address Breakpoint 0 (DAB0)        | 8H  |
| Data Address Breakpoint 1 (DAB1)        | CH  |
| Interrupt Map 0 (IMAP0)                 | 10H |
| Interrupt Map 1 (IMAP1)                 | 14H |
| Interrupt Map 2 (IMAP2)                 | 18H |
| Interrupt Control (ICON)                | 1CH |
| Memory Region 0 Configuration (MCON0)   | 20H |
| Memory Region 1 Configuration (MCON1)   | 24H |
| Memory Region 2 Configuration (MCON2)   | 28H |
| Memory Region 3 Configuration (MCON3)   | 2CH |
| Memory Region 4 Configuration (MCON4)   | 30H |
| Memory Region 5 Configuration (MCON5)   | 34H |
| Memory Region 6 Configuration (MCON6)   | 38H |
| Memory Region 7 Configuration (MCON7)   | 3CH |
| Memory Region 8 Configuration (MCON8)   | 40H |
| Memory Region 9 Configuration (MCON9)   | 44H |
| Memory Region 10 Configuration (MCON10) | 48H |
| Memory Region 11 Configuration (MCON11) | 4CH |
| Memory Region 12 Configuration (MCON12) | 50H |
| Memory Region 13 Configuration (MCON13) | 54H |
| Memory Region 14 Configuration (MCON14) | 58H |
| Memory Region 15 Configuration (MCON15) | 5CH |
| Reserved (Initialize to 0)              | 60H |
| Breakpoint Control (BPCON)              | 64H |
| Trace Controls (TC)                     | 68H |
| Bus Configuration Control (BCON)        | 6CH |

F\_CA002A

Figure F-1. Control Table

Section 2.3, "CONTROL REGISTERS" (pg. 2-6)

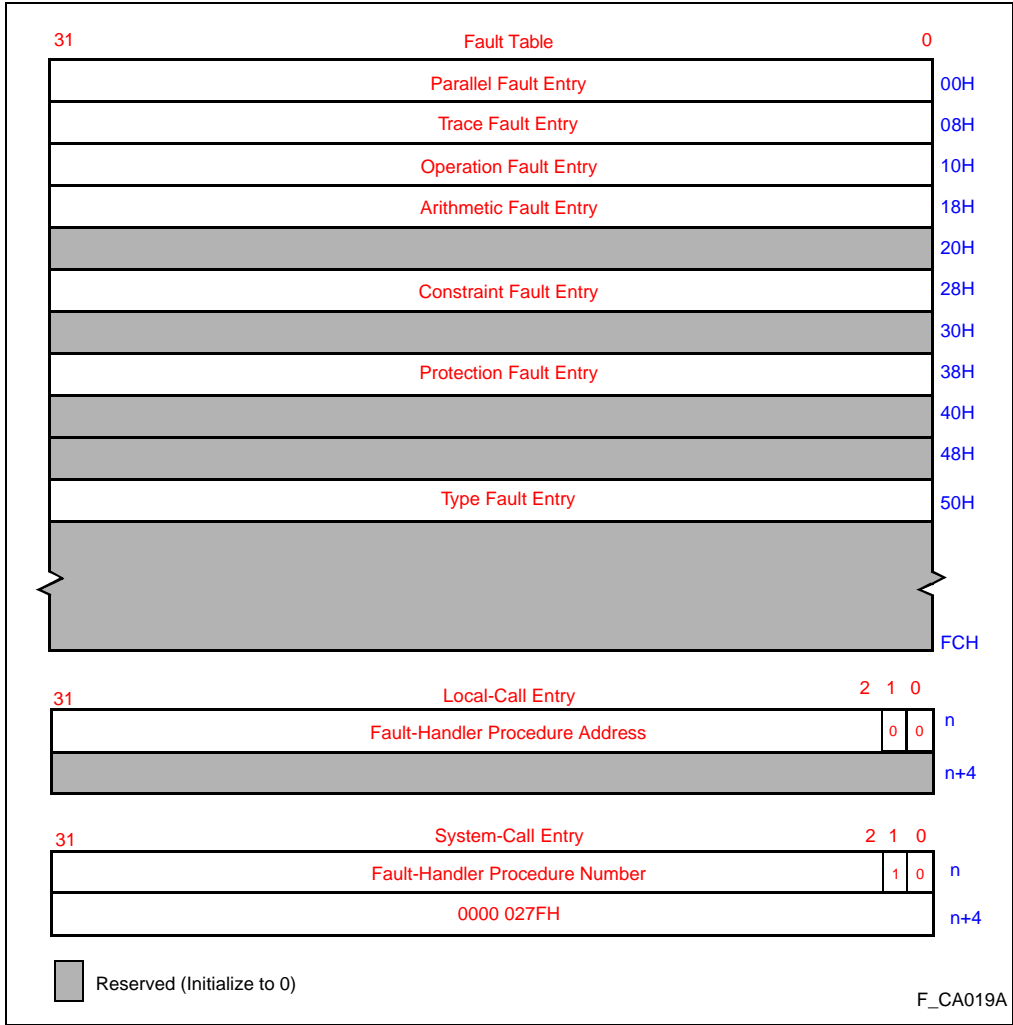




**Figure F-2. Fault Record**

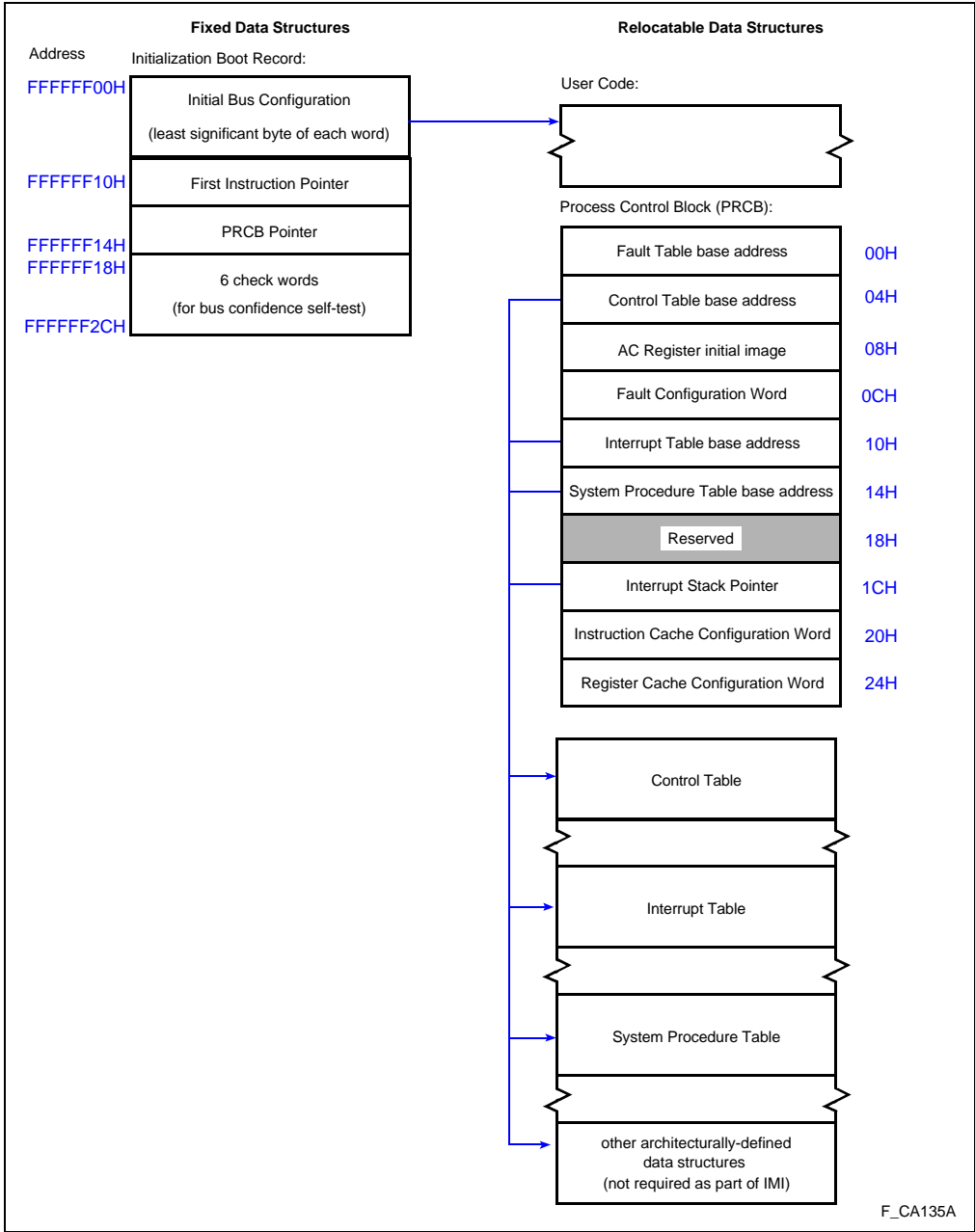
Section 7.5.1, "Fault Record Data" (pg. 7-6)





**Figure F-3. Fault Table and Fault Table Entries**

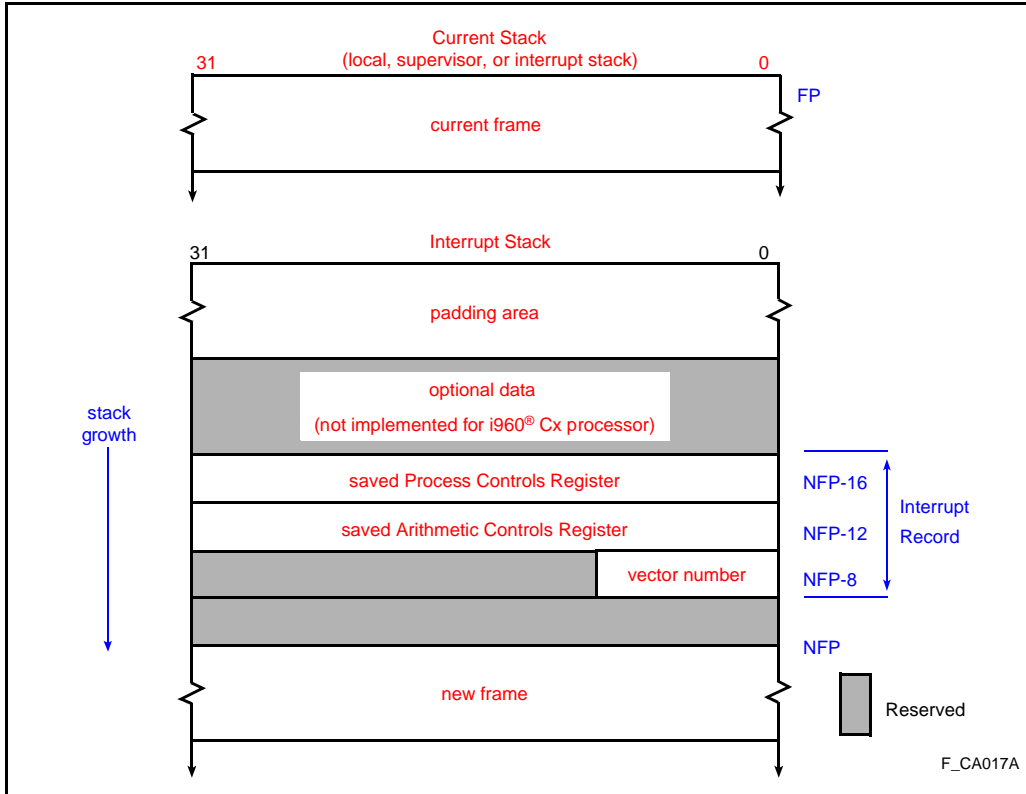
Section 7.3, "FAULT TABLE" (pg. 7-4)



**Figure F-4. Initial Memory Image (IMI) and Process Control Block (PRCB)**

Section 14.2.5, "Initialization Boot Record (IBR)" (pg. 14-5)





**Figure F-5. Storage of an Interrupt Record on the Interrupt Stack**

Section 6.7, "INTERRUPT STACK AND INTERRUPT RECORD" (pg. 6-9)



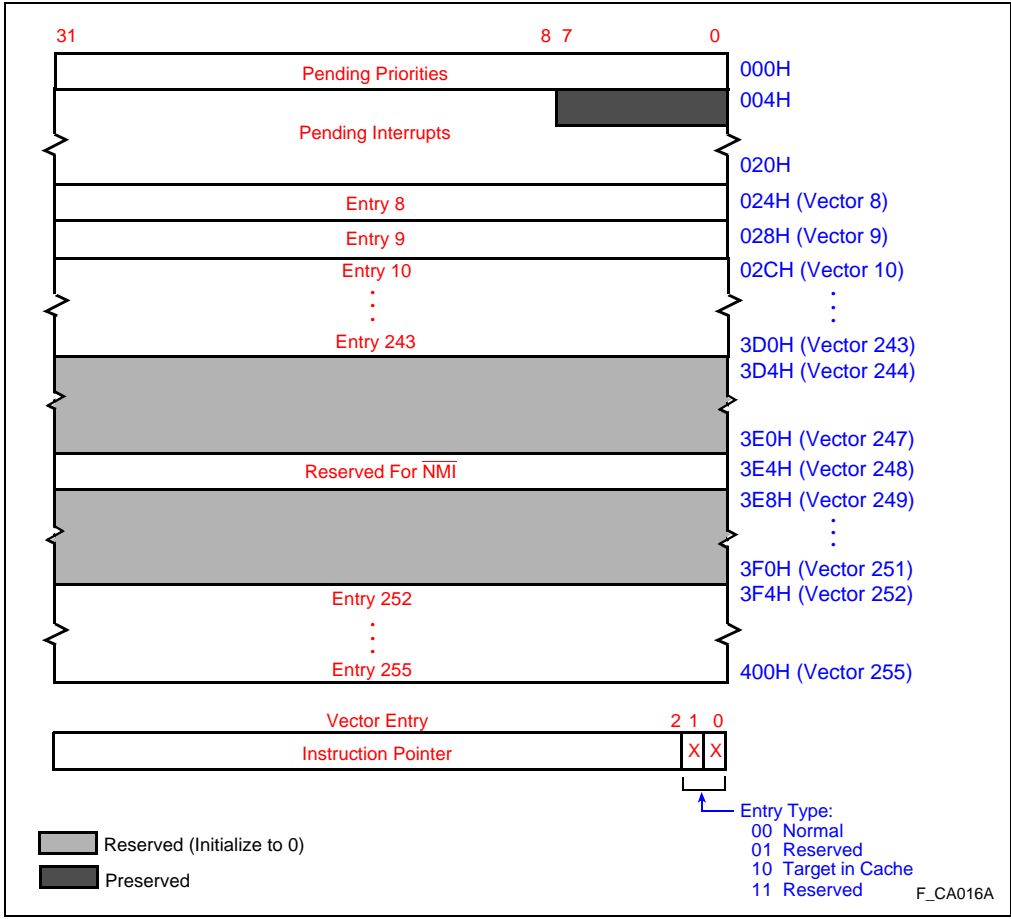
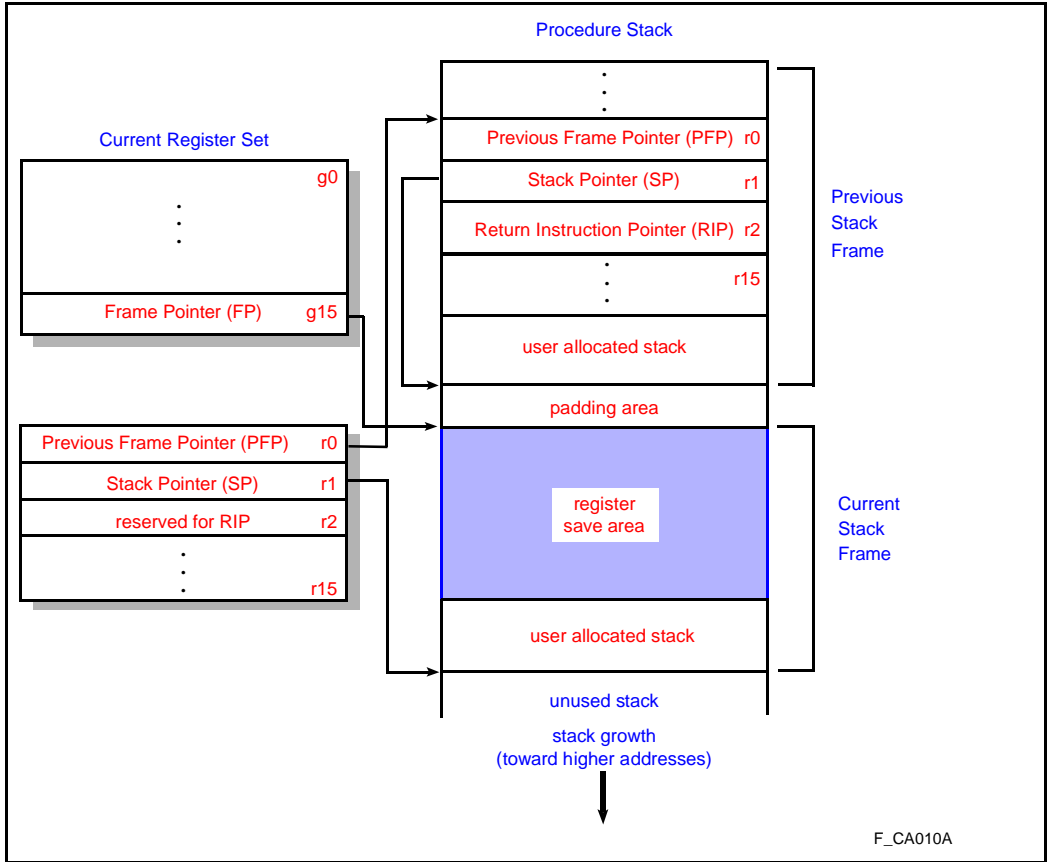


Figure F-6. Interrupt Table

Section 6.4, "INTERRUPT TABLE" (pg. 6-3)



**Figure F-7. Procedure Stack Structure and Local Registers**

Section 5.2.1, "Local Registers and the Procedure Stack" (pg. 5-2)



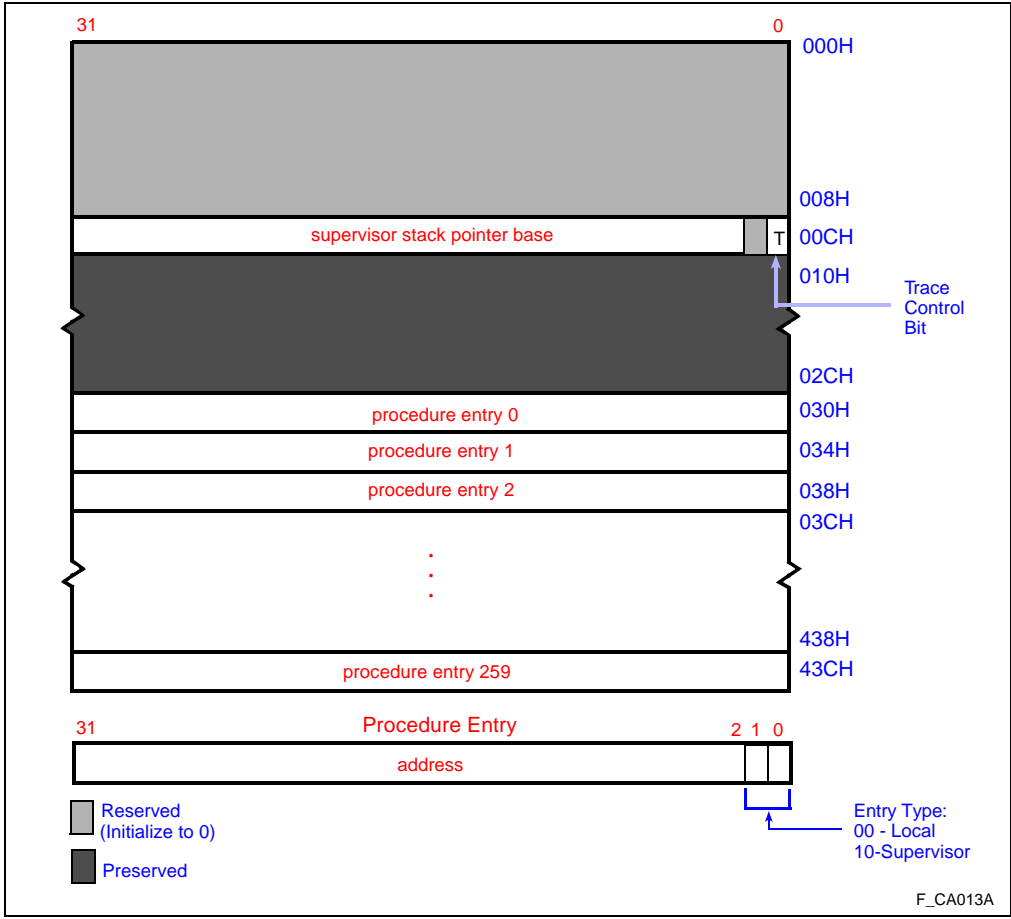


Figure F-8. System Procedure Table

Section 5.5.1.1, "Procedure Entries" (pg. 5-14)



F.2 Registers

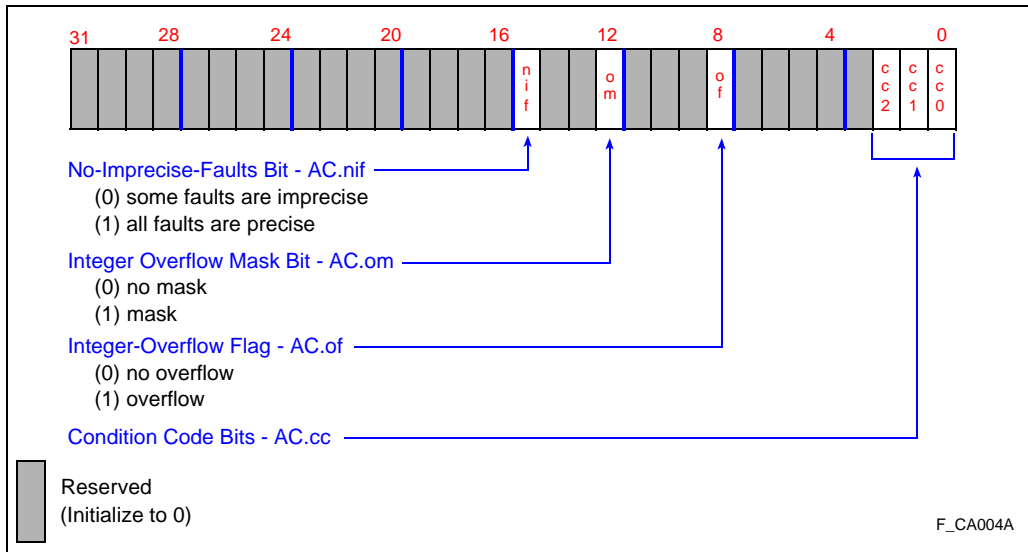


Figure F-9. Arithmetic Controls Register (AC)

Section 2.6.2, "Arithmetic Controls (AC) Register" (pg. 2-15)

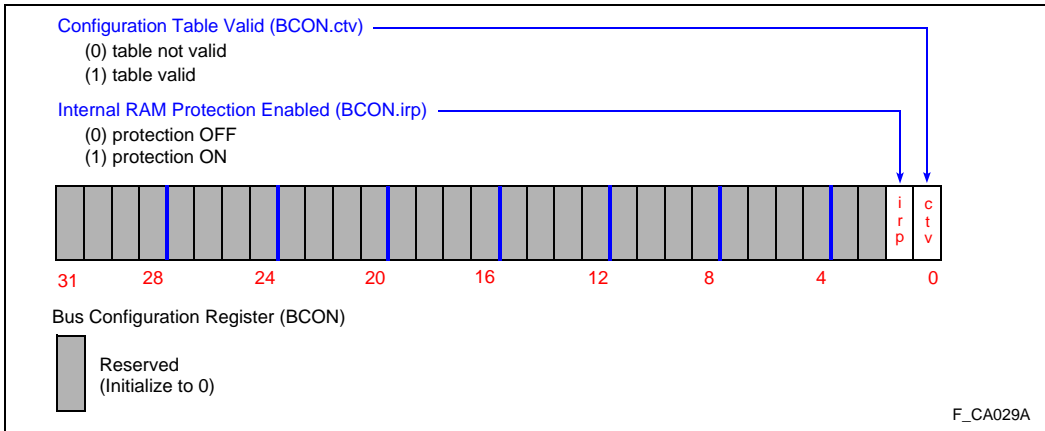
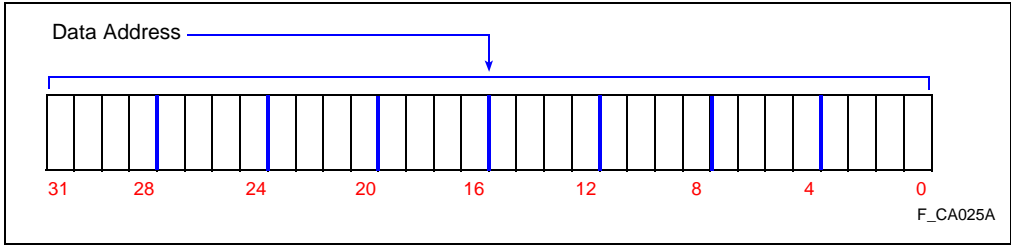


Figure F-10. Bus Configuration Register (BCON)

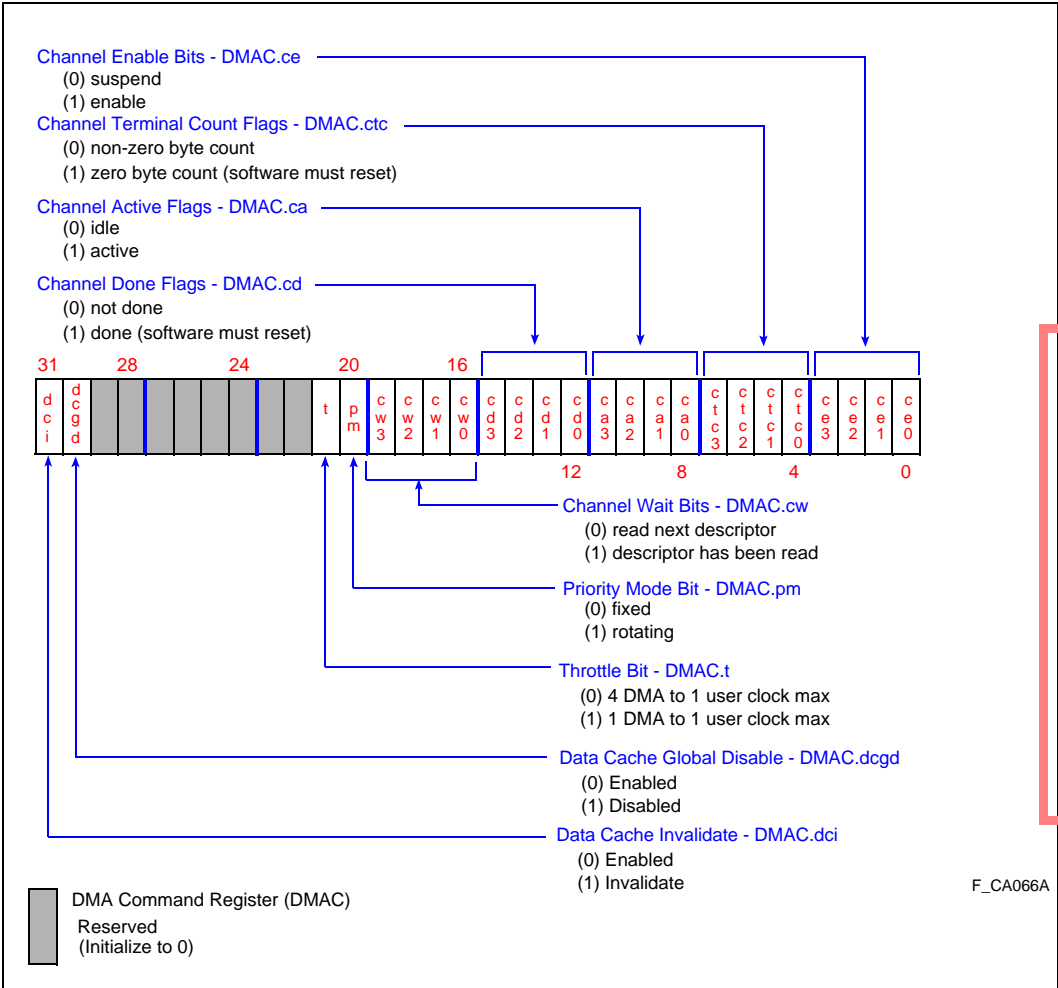
Section 10.3.2, "Bus Configuration Register (BCON)" (pg. 10-8)





**Figure F-11. Data Address Breakpoint Registers**

Section 8.2.7, "Breakpoint Trace" (pg. 8-5)



ERRATA: 7/11/94  
 DMA Command Register bits 30 (Data Cache Global Disable) and 31 (Data Cache Invalidate) not defined in Figure 13-9 or in the text that follows the figure.  
 These were correctly defined in the i960® CF Microprocessor Reference Manual Supplement and unintentionally omitted from this manual.

**Figure F-12. DMA Command Register (DMAC)**

Section 13.10.1, "DMA Command Register (DMAC)" (pg. 13-21)



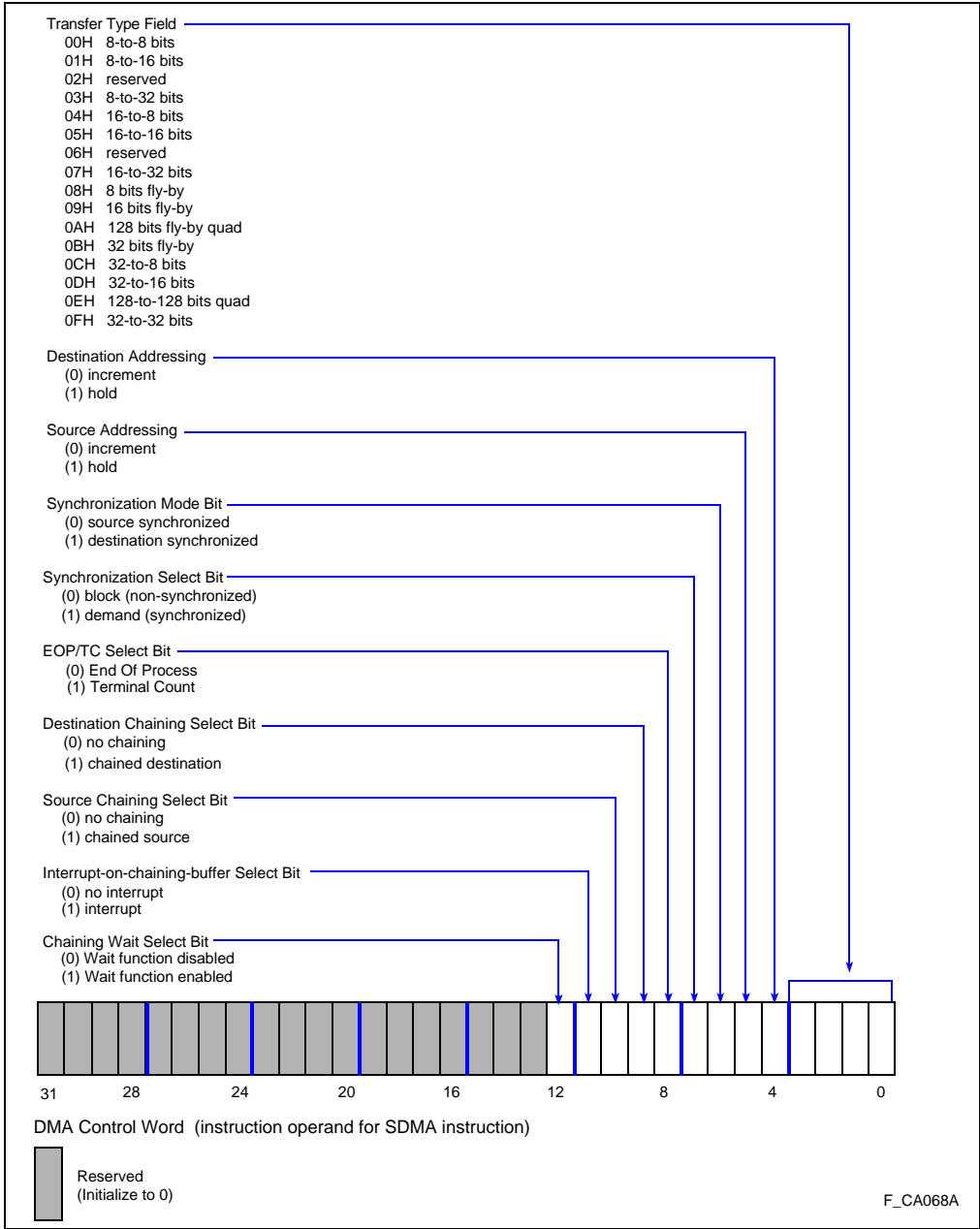


Figure F-13. DMA Control Word

Section 13.10.3, "DMA Control Word" (pg. 13-25)

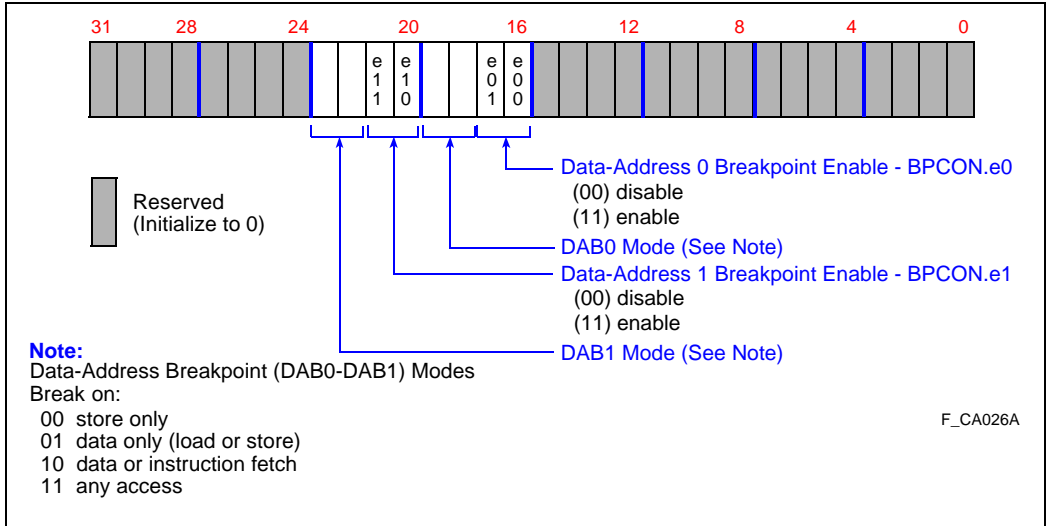


Figure F-14. Hardware Breakpoint Control Register (BPCON)

Section 8.2.7, "Breakpoint Trace" (pg. 8-5)

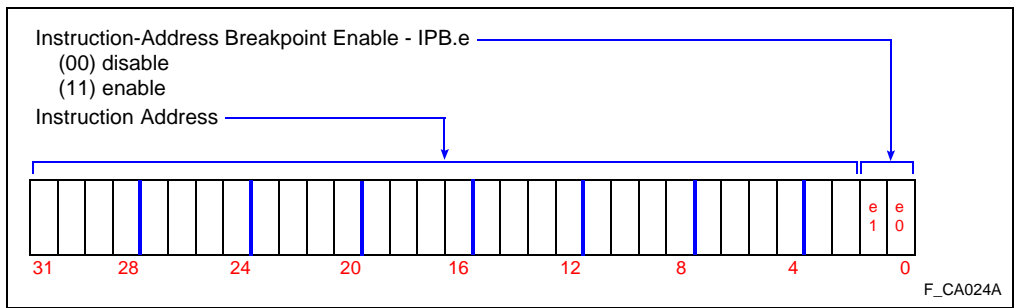
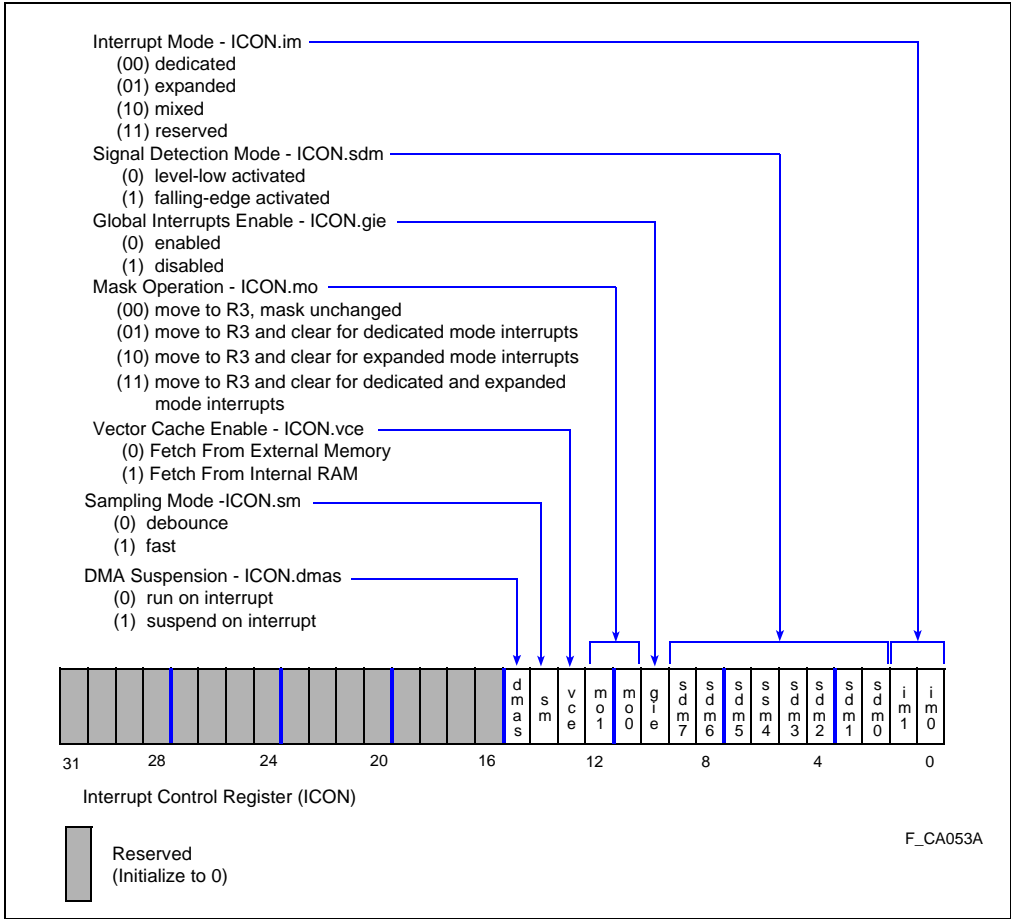


Figure F-15. Instruction Address Breakpoint Registers (IPB0 - IPB1)

Section 8.2.7, "Breakpoint Trace" (pg. 8-5)

**F**



Errata (12-06-94 SRB)  
 Vector Cache Enable bits (ICON.vce) incorrectly defined.  
 Bit 0 was "debounce"; it now is correctly defined as "Fetch From External Memory".  
 Bit 1 was "Fast"; is now correctly defined as "Fetch From Internal RAM".

**Figure F-16. Interrupt Control (ICON) Register**

Section 12.3.4, "Interrupt Control Register (ICON)" (pg. 12-11)

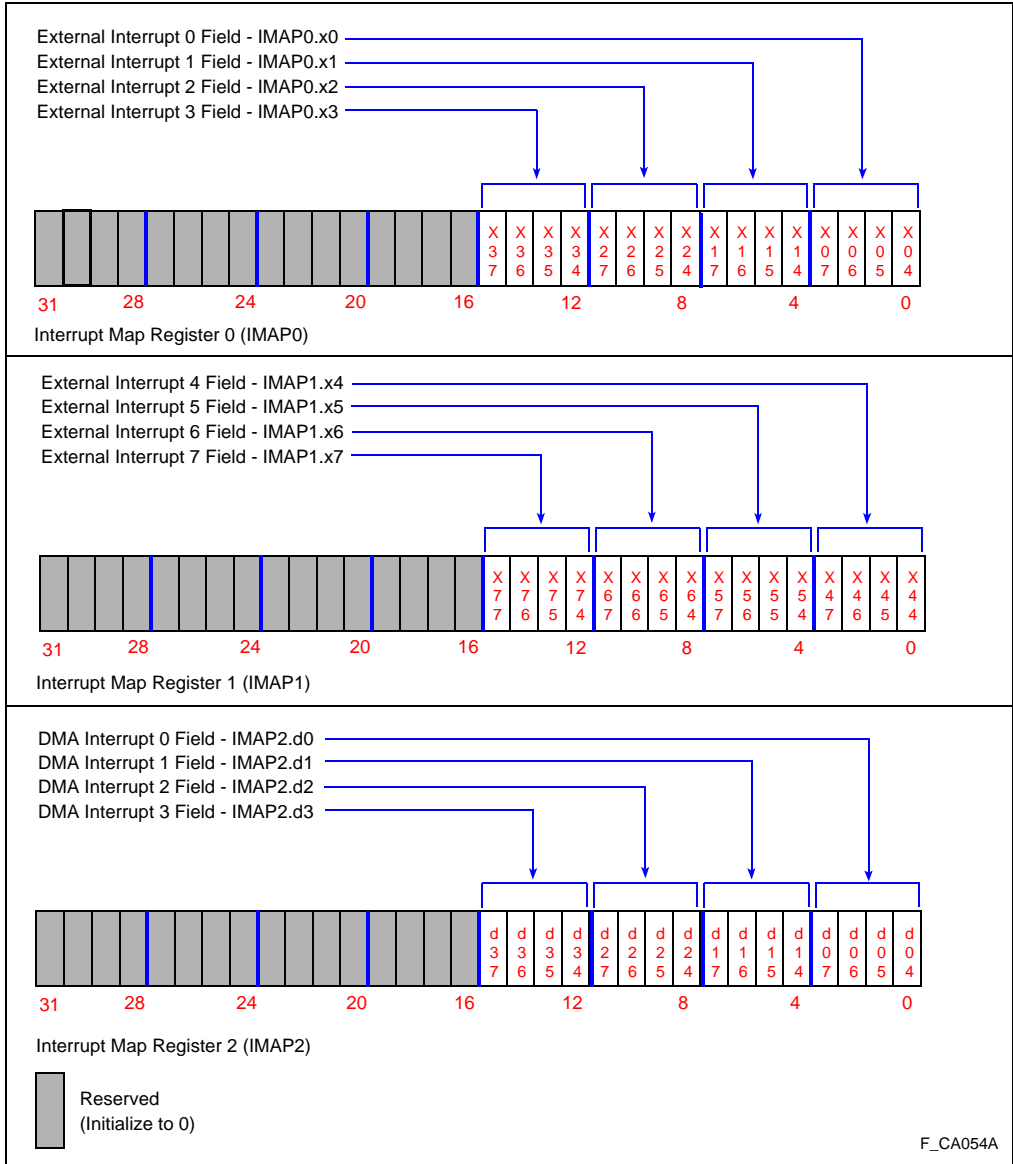
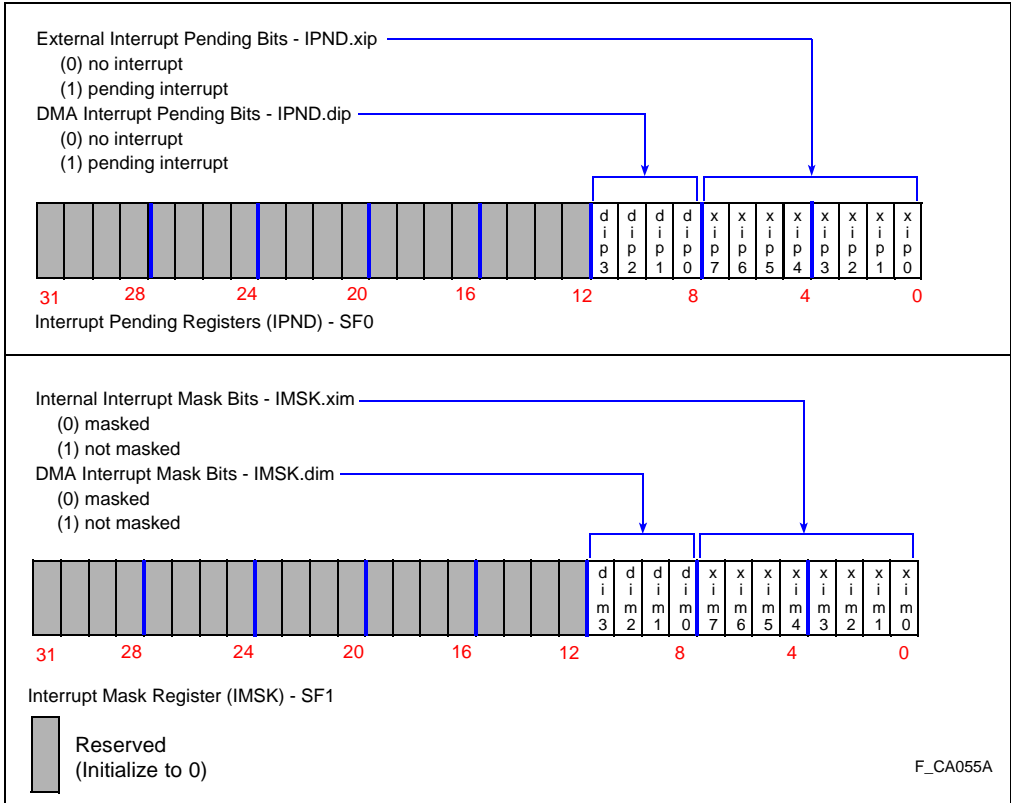


Figure F-17. Interrupt Map (IMAP0 - IMAP2) Registers

Section 12.3.5, "Interrupt Mapping Registers (IMAP0-IMAP2)" (pg. 12-12)



**Figure F-18. Interrupt Mask (IMSK) and Interrupt Pending (IPND) Registers**

Section 12.3.6, "Interrupt Mask and Pending Registers (IMSK, IPND)" (pg. 12-14)

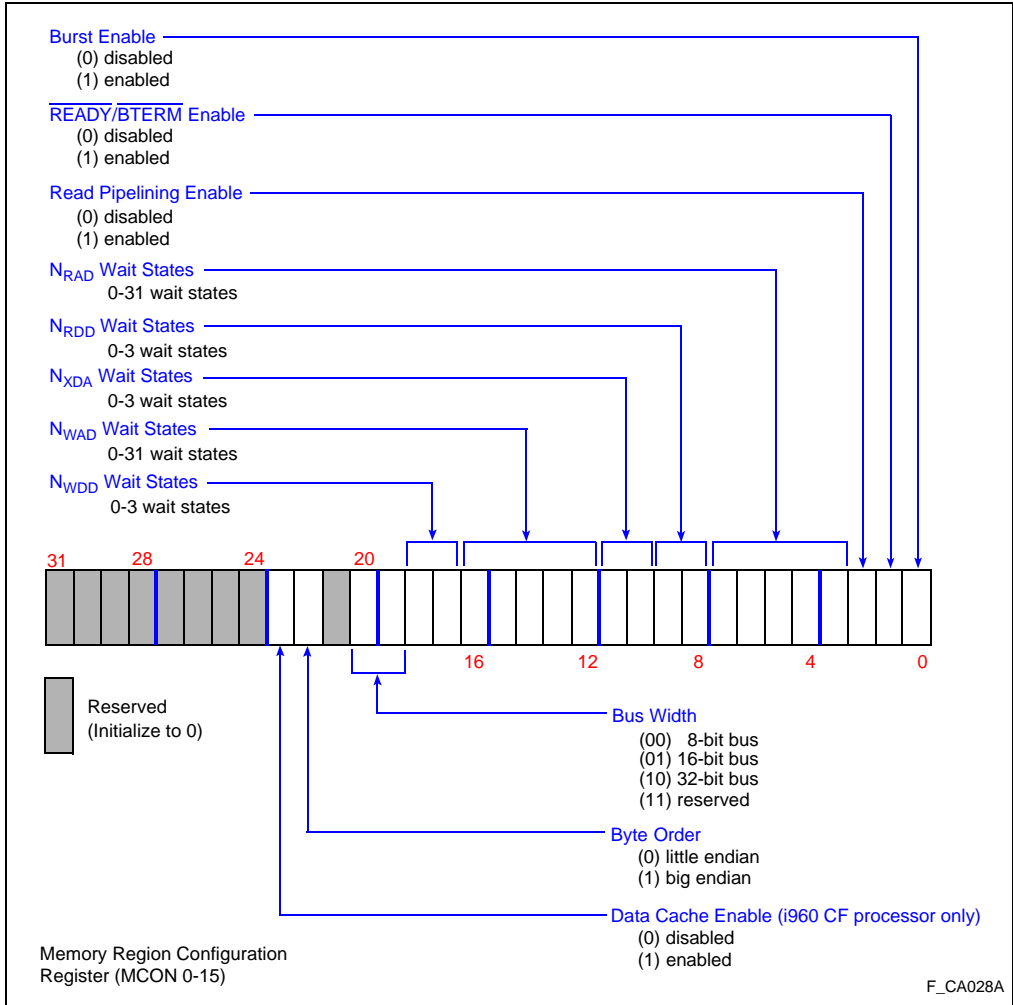
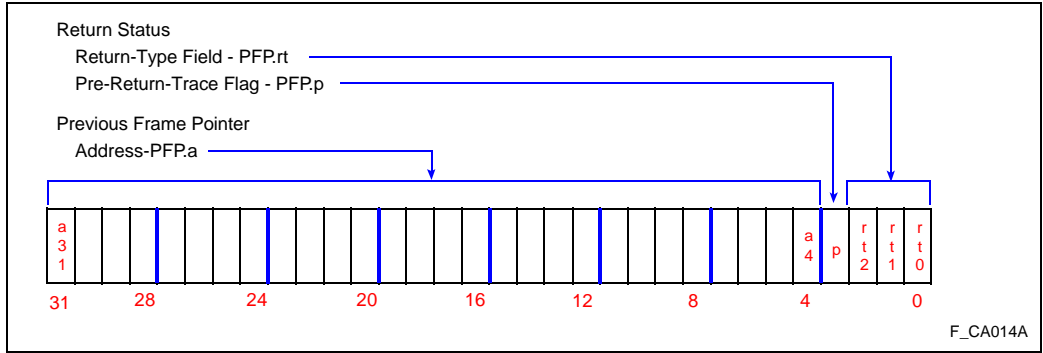


Figure F-19. Memory Region Configuration Register (MCON 0-15)

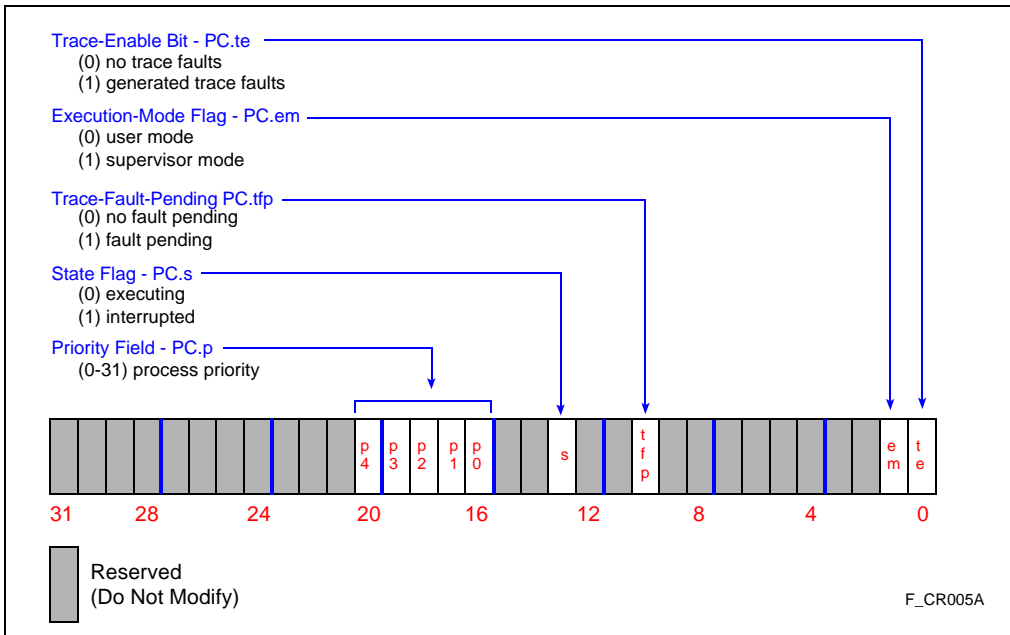
Section 10.3.1, "Memory Region Configuration Registers (MCON 0-15)" (pg. 10-6)





**Figure F-20. Previous Frame Pointer Register (PFPR) (r0)**

Section 5.8, "RETURNS" (pg. 5-16)



**Figure F-21. Process Controls (PC) Register**

Section 2.6.3.1, "Initializing and Modifying the PC Register" (pg. 2-19)



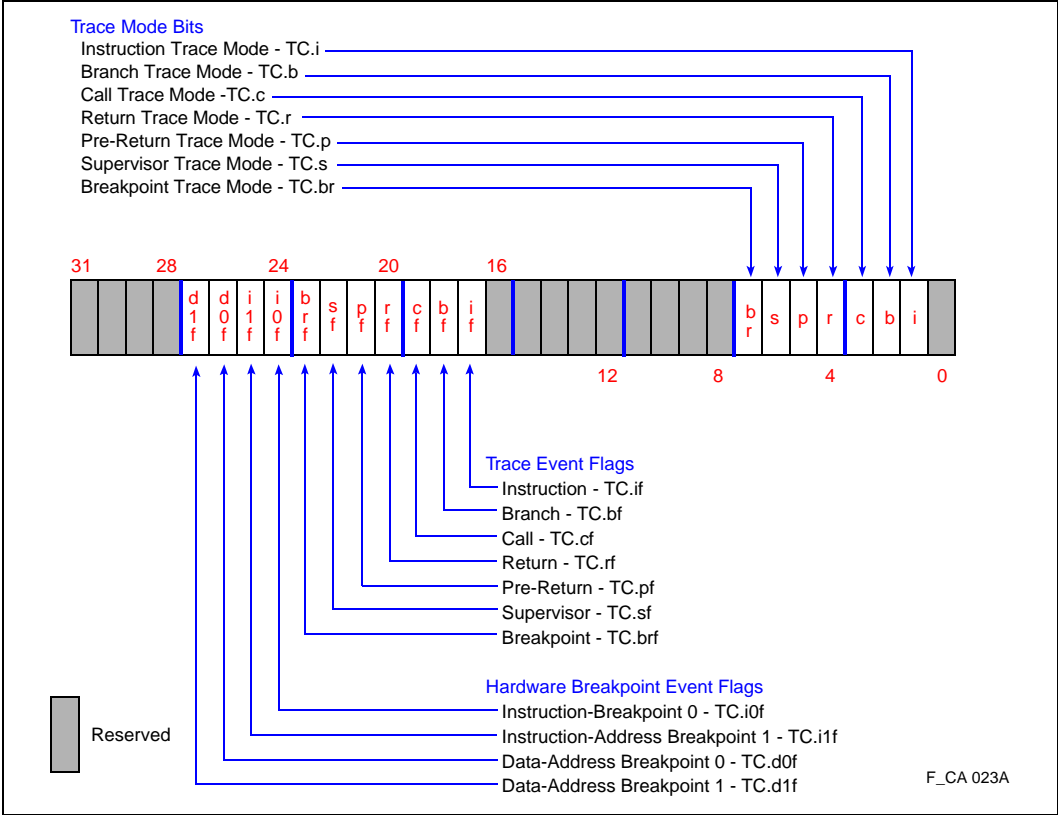


Figure F-22. Trace Controls (TC) Register

Section 8.1.1, "Trace Controls (TC) Register" (pg. 8-2)



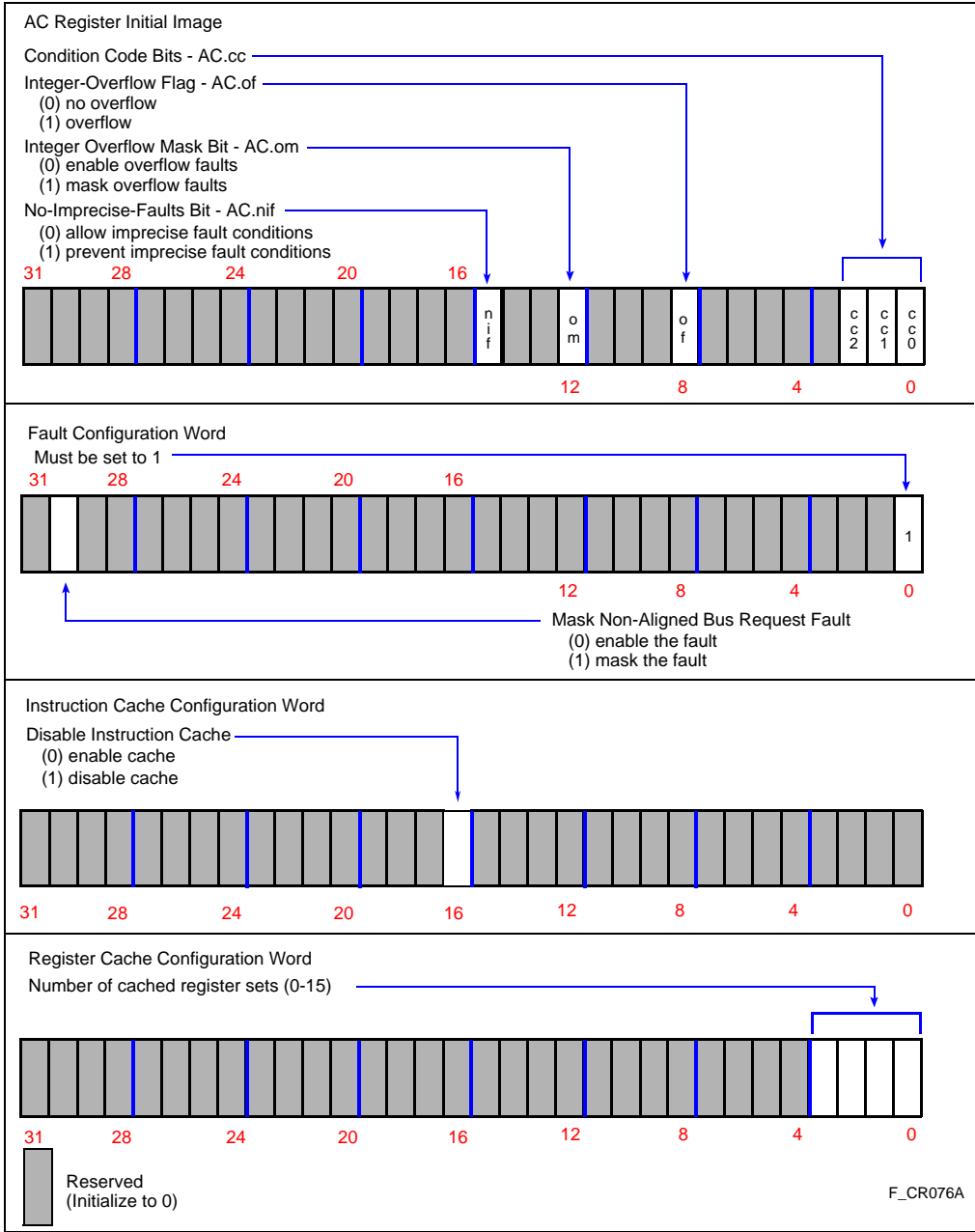


Figure F-23. Process Control Block Configuration Words

Section 14.3, "REQUIRED DATA STRUCTURES" (pg. 14-11)



# INDEX

I



**A**

## Absolute

- absolute displacement 3-6
- absolute offset 3-6

## AC register

- initial image 14-10
- see also Arithmetic Controls (AC) register

**add\*** 9-9**addc** 9-8**addi, addo** 9-9

## Address Generation Unit (AGU) A-7, A-25

## Address Space Restrictions

- data cache C-3
- data structure alignment C-3
- instruction cache C-2
- internal data RAM C-2
- reserved memory C-2
- stack frame alignment C-3

## addressing registers and literals 2-5

## AGU (address generation unit) A-7

## alignment of registers and literals 2-5

**alterbit** 9-10**and, andnot** 9-11

## argument list 5-10

## Arithmetic Controls (AC) register 2-15

- condition code flags 2-16
- initialization 2-16
- integer overflow flag 2-17
- no imprecise faults bit 2-17

## arithmetic instructions 4-6

- add, subtract, multiply or divide 4-7
- extended-precision instructions 4-8
- remainder and modulo instructions 4-8
- shift and rotate instructions 4-9

## arithmetic operations and data types 4-7

**atadd** 9-12**atmod** 9-13

## atomic access 2-10

Atomic instructions ( $\overline{\text{LOCK}}$  signal) 4-18, 11-26**B****b\*** 9-19**b, bx** 9-14**bal, balx** 9-15**bb\*** 9-17**bbc, bbs** 9-17

## BCU, see Bus Control Unit

**be, bg, bge** 9-19

## big endian 2-12, 11-24

## bit definition 1-7

## bit, bit field and byte instructions 4-10

- bit field instructions 4-11
- bit instructions 4-10
- byte instructions 4-12

## bits and bit fields 3-3

**bl, ble, bne** 9-19

## Block-mode transfers (DMA) 13-1

**bo, bno** 9-19

## branch instructions 4-13, 9-19

- compare and branch instructions 4-15
- conditional branch instructions 4-15
- unconditional branch instructions 4-14

## branch prediction 4-2

## branch-and-link 5-1

- coding calls 5-1
- returning from 5-18

## Breakpoint Trace Event 9-6

## breakpoints C-6

## built-in self test 14-2

## burst access 10-3

## bus access 11-2

bus backoff input ( $\overline{\text{BOFF}}$ ) 11-29

## INDEX

- Bus Configuration (BCON) register 10-5, 10-8
- Bus Control Unit A-26
  - loads A-26
  - queue entries A-27
  - stores A-26
- bus controller
  - configuration 10-9, 11-2
  - instruction fetches 10-1
  - load and store instructions 10-1
  - memory regions 10-1
  - overview 1-4, 10-1
  - programming 10-2, 10-5
  - queue 10-14
  - wait state generator 10-3
- bus requests 11-1
  - aligned 10-9
  - little endian memory regions 10-9
  - operation-unaligned fault 10-9
  - unaligned 10-9
  - unsupported unaligned 10-10
- bus translation unit 10-15
- bus width 11-10
- byte ordering
  - big and little endian 11-24
- C**
- CA/CF functional units A-2
- cache
  - load-and-lock 2-14, 12-21
  - locking 4-21
- cache replacement A-36
- caching of local register sets 5-6
  - frame fills 5-6
  - frame spills 5-6
  - mapping to the procedure stack 5-9
  - updating the register cache 5-9
- call** 5-2, 9-21
- call and return instructions 4-16
- call and return mechanism 5-1, 5-2
  - explicit calls 5-1
  - implicit calls 5-1
- local register cache 5-3
- local registers 5-2
- procedure stack 5-3
- register and stack management 5-4
  - frame pointer 5-4
  - previous frame pointer 5-4
  - return instruction pointer 5-5
  - return type field 5-4
  - stack pointer 5-4
- stack frame 5-2
- call and return operations 5-5
  - call operation 5-5
  - return operation 5-6
- calls** 5-2, 9-22
- call-trace mode 8-4
- callx** 5-2, 9-24
- chkbit** 9-26
- clock input (CLKIN) 14-26
- clrbit** 9-27
- cmp\*** 9-29
- cmpdec\*** 9-28
- cmpdeci, cmpdeco** 9-28
- cmpi, cmpo** 9-29
- cmpib\*, cmpob\*** 9-31
- cmpibe, cmpibne, cmpibl, cmpible** 9-31
- cmpibg, cmpibge, cmpibo, cmpibno** 9-31
- cmpinc\*** 9-30
- cmpinci, cmpinco** 9-30
- cmpobe, cmpobne** 9-31
- cmpobg, cmpobge** 9-31
- cmpobl, cmpoble** 9-31



## Coding Optimizations

- branch prediction A-53
- branch target alignment A-53
- comparison and branching A-46
- compressing algorithms using branching A-54
- data cache A-55
- data RAM A-55
- instruction cache A-55
- loads and stores A-44
- loop expansion A-46
- maximizing instruction execution A-49
- multiplication and division A-45
- on-chip storage A-55
- register cache A-56
- reordering code for parallel issue A-48
- cold reset 12-15, 14-2
- comparison instructions 4-12, 9-31
  - compare and conditional compare instructions 4-12
  - compare and increment or decrement instructions 4-13
  - test condition instructions 4-13
- concmp\*** 9-34
- concmpi, concmpo** 9-34
- conditional fault instructions 4-17
- configurable memory regions (see also MCON) 10-1
- Control Pipeline
  - conditional branches A-32
  - unconditional branches A-28
- control registers 2-1, 2-7
- control table 2-1, 2-6, 2-8
  - initialization 14-11
- core architecture A-1
- core architecture mechanisms C-1

## D

- data alignment 3-4
- data alignment in external memory 2-11
- data cache 2-14, A-8
  - BCU interaction A-11
  - bus configuration A-9
  - coherency A-10
    - BCU queues A-12
    - DMA operation A-13
    - I/O and bus masters A-13
  - data fetch policy A-10
  - global control A-9
  - hits and misses A-8
  - organization A-8
  - subblock placement A-8
  - write policy A-10
- data control peripheral units C-6
- data fetch policy A-10
- data movement instructions 4-5
  - load address instruction 4-6
  - load instructions 4-5
  - move instructions 4-6
- data packing unit 10-15
- Data RAM A-24
- Data RAM (DR) A-7
- data structure locations 2-10



- data structures
  - control table 2-1, 2-6, 2-8
  - fault table 2-1, 2-8
  - initialization boot record 2-1, 2-8
  - interrupt stack 2-1, 2-8
  - interrupt table 2-1, 2-8
  - local stack 2-1
  - processor control block 2-1, 2-8
  - supervisor stack 2-1, 2-8
  - system procedure table 2-1, 2-8
  - user stack 2-8
- data types
  - bits and bit fields 3-3
  - data alignment 3-4
  - integers 3-2
  - ordinals 3-3
  - triple and quad words 3-4
- debug
  - overview 8-1
- debug instructions 4-17
- decoupling capacitors 14-28
- Demand-mode transfers (DMA) 13-1
- design considerations
  - high frequency 14-29
  - interference 14-31
  - latchup 14-31
  - line termination 14-30
  - performance A-1
- die stepping information
  - location 2-3
- Direct Memory Access (DMA) Controller 13-1
- div\*** 9-35
- divi, divo** 9-35

- DMA
  - block mode 13-2
  - block-mode transfers 13-1
  - byte count alignment 13-10
  - data assembly 13-9
  - data chaining 13-13
  - data disassembly 13-9
  - data RAM 13-27
  - demand mode 13-2
  - demand mode transfers 13-1, 13-8
  - demand mode, starting 13-31
  - end-of-process 13-32
  - execution 13-1
  - fixed addresses 13-10
  - Fly-by transfers 13-5
  - latency 13-40
  - multi-cycle transfers 13-3
  - overview 13-1
  - pin definitions 13-30
  - setup and control 13-2
  - terminal count 13-32
  - termination 13-2
  - transfer 13-3
  - transfer type 13-3
  - unaligned DMA transfers 13-10
- DMA command register (DMAC) 13-21
- DMA controller
  - Block mode DMAs 13-33
  - overview 1-4
- DMAC register 13-20

## E

- ediv** 9-36
- effective address (*efa*) A-25
- effective address calculations A-26
- electromagnetic interference (EMI) 14-32
- electrostatic interference (ESI) 14-32



**emul** 9-37

**eshro** 9-38

EU (execution unit) A-7

executable group A-15, A-29

Execution Unit (EU) A-7, A-20

explicit calls 5-1

extended addressing instructions 4-14

extended register set C-5

external interrupt pins ( $\overline{XINT7:0}$ ) 12-9

external memory requirements 2-10

external system requirements C-6

**extract** 9-39

## F

fault conditions 7-1

fault handling

data structures 7-1

during program execution 7-2

fault record 7-2, 7-6

fault table 7-2, 7-4

fault type and subtype numbers 7-2

fault types 7-4

local calls 7-2

multiple fault conditions 7-9

return instruction pointer (RIP) 7-7

returning to an alternate point in the program  
7-14

stack frame alignment 7-8

stack usage 7-6

supervisor stack 7-2

system procedure table 7-2

system-local calls 7-2

system-supervisor calls 7-2

user stack 7-2

fault handling procedure

invocation 7-6

fault instructions 9-40

fault record 7-6

address-of-faulting-instruction field 7-6

fault subtype field 7-6

fault type field 7-6

location 7-6, 7-8

optional data fields 7-7

size 7-8

structure 7-6

fault table 2-1, 2-8, 7-4

local-call entry 7-6

location 7-4

system-call entry 7-6

fault type and subtype numbers 7-2

fault types 7-4

**fault\*** 9-40

**faulte, faultne, faultl, faultle** 9-40

**faultg, faultge** 9-40

**faulto, faultno** 9-40

faults C-6

NIF bit 7-19

overview 1-4

precision (**syncf**) 7-19

fetch latency A-34

fetch strategy A-34

field definition 1-7

flag definition 1-7

**flushreg** 5-9, 9-42

fly-by transfer mode 13-2, 13-5

**fmark** 9-43

FP (Frame Pointer - g15) 5-4

frame fills 5-6

Frame Pointer (FP) 5-4

location 2-3

frame spills 5-6

## INDEX

## G

global registers 2-1, 2-2  
 overview 1-7

## I

IBR, see initialization boot record

ICON register 12-11

IMAP registers 12-12

IMI 14-5

implementation-specific features C-1

implicit calls 5-1, 7-2

IMSK register 12-7, 12-14

Index with Displacement 3-7

indivisible access 2-10

initial memory image (IMI) 14-5

initialization 14-1, 14-2

CLKIN 14-26

data structure locations 14-11

hardware requirements 14-26

power and ground 14-27

Initialization Boot Record (IBR) 2-1, 2-8, 14-5

initialization mechanism C-5

instruction buffer 2-14

Instruction Cache

cache replacement A-36

fetch latency A-34

fetch strategy A-34

locking A-33

instruction cache 2-1, 2-13, 4-21

bus snooping 2-13

configuration 2-13, A-33

disabling 2-13

enabling and disabling 14-10

instruction buffer 2-14

invalidation 2-13

load-and-lock mechanism 2-14

**sysctl** 2-14

overview 1-1

size 2-13, A-33

Instruction Fetch Unit A-34

Instruction flow A-4

decode stage A-5

execute stage A-5

issue stage A-5

instruction formats 4-3

assembly language format 4-1

branch prediction 4-2

instruction encoding format 4-2

Instruction Pointer (IP) register 2-15

Instruction Scheduler (IS) 12-22, A-3

instruction cache A-4

instruction fetch unit A-4

microcode A-4

Instruction Set

implementation-specific instructions C-4

instruction timing C-4

## instruction set

**add\*** 9-9  
**addc** 9-8  
**addi, addo** 9-9  
**alterbit** 9-10  
**and, andnot** 9-11  
**atadd** 9-12  
**atmod** 9-13  
**b\*** 9-19  
**b, bx** 9-14  
**bal, balx** 9-15  
**bb\*** 9-17  
**bbc, bbs** 9-17  
**be, bg, bge** 9-19  
**bl, ble, bne** 9-19  
**bo, bno** 9-19  
**call** 9-21  
**calls** 9-22  
**callx** 9-24  
**chkbit** 9-26  
**clrbit** 9-27  
**cmp\*** 9-29  
**cmpdec\*** 9-28  
**cmpdeci, cmpdeco** 9-28  
**cmpi, cmpo** 9-29  
**cmpib\*, cmpob\*** 9-31  
**cmpibe, cmpibne, cmpibl, cmpible** 9-31  
**cmpibg, cmpibge, cmpibo, cmpibno** 9-31  
**cmpinc\*** 9-30  
**cmpinci, cmpinco** 9-30  
**cmpobe, cmpobne** 9-31  
**cmpobg, cmpobge** 9-31  
**cmpobl, cmpoble** 9-31  
**concmp\*** 9-34  
**concmpi, concmpo** 9-34  
**div\*** 9-35  
**divi, divo** 9-35

## instruction set (continued)

**ediv** 9-36  
**emul** 9-37  
**eshro** 9-38  
**extract** 9-39  
**fault\*** 9-40  
**faulte, faultne, faultl, faultle** 9-40  
**faultg, faultge** 9-40  
**faulto, faultno** 9-40  
**flushreg** 9-42  
**fmark** 9-43  
**ld\*** 9-44  
**ld, ldl, ldt, ldq** 9-44  
**lda** 9-46  
**ldib, ldis** 9-44  
**ldob, ldos** 9-44  
**mark** 9-47  
**modac** 9-48  
**modi** 9-49  
**modify** 9-50  
**modpc** 9-51  
**modtc** 9-52  
**mov\*** 9-53  
**mov, movl, movt, movq** 9-53  
**mul\*** 9-54  
**muli, mulo** 9-54  
**nand** 9-55  
**nor** 9-56  
**not, notand** 9-57  
**notbit** 9-58  
**notor** 9-59  
**or, ornot** 9-60  
**remi, remo** 9-61  
**ret** 9-62  
**rotate** 9-64  
**scanbit** 9-65  
**scanbyte** 9-66

## INDEX

- instruction set (continued)
  - sdma** 9-67
  - setbit** 9-68
  - sh\*** 9-69
  - shl, shri, shr, shrdi** 9-69
  - shlo, shro** 9-69
  - spanbit** 9-72
  - st\*** 9-73
  - st, stl, stt, stq** 9-73
  - stib, stis** 9-73
  - stob, stos** 9-73
  - sub\*** 9-76
  - subc** 9-75
  - subi, subo** 9-76
  - sysctl** 9-78
  - syncf** 9-77
  - test\*** 9-81
  - teste, testne, testl, testle** 9-81
  - testg, testge** 9-81
  - testo, testno** 9-81
  - udma** 9-83
  - xnor, xor** 9-84
- instruction set functional groups 4-4
- Instruction Trace Event 9-6
- instructions
  - parallel execution 1-1
  - parallel issue A-14
  - parallel processing A-14
  - scoreboarding A-17
- instruction-trace mode 8-4
- integers 3-2
  - data truncation 3-2
  - sign extension 3-2
- internal data RAM 2-12, 10-13
  - local register cache 2-12
  - location 2-12
  - modification 2-13
  - reserved areas 2-12
  - write protection 2-13
- interrupt controller 12-1
  - configuration 12-16
  - interrupt pins 12-9
  - overview 1-5, 12-1
  - program interface 12-1
  - programmer interface 12-11
  - setup 12-16
- interrupt handling procedures 6-10
  - AC and PC registers 6-10
  - address space 6-11
  - global registers 6-11
  - instruction cache 6-11
  - interrupt stack 6-10
  - local registers 6-10
  - location 6-10
  - special function registers 6-11
  - supervisor mode 6-10
- interrupt latency 12-18
- interrupt mask
  - saving 12-7
- interrupt pins
  - dedicated mode 12-2
  - expanded mode 12-2
  - mixed mode 12-2
- interrupt posting 6-1
- interrupt procedure pointer 6-5
- interrupt record 6-9
  - location 6-9
- interrupt request management 12-2



interrupt requests

- interrupt controller 6-6
- origination 6-6
- sysctl** 6-8

interrupt service latency 12-17

interrupt servicing mechanism C-5

interrupt stack 2-1, 2-8, 6-9

- structure 6-9

interrupt table 2-1, 2-8, 6-3

- alignment 6-3
- caching mechanism 6-6
- initialization 14-11
- location 6-3
- $\overline{\text{LOCK}}$  pin 6-7
- locking 6-6
- pending interrupts 6-5
- vector entries 6-4

interrupts

- checking pending 12-17
- clearing the source 12-5
- dedicated mode 12-4
- dedicated mode posting 12-4
- definition 6-1
- DMA operations 12-2
- DMA suspension 12-21
- expanded mode 12-5
- function 6-1
- internal RAM 12-20
- interrupt context switch 6-11
- interrupt handling procedures 6-10
- interrupt record 6-9
- interrupt stack 6-9
- interrupt table 6-3
- masking hardware interrupts 12-8
- mixed mode 12-7
- non-maskable 12-7
- non-maskable interrupt (NMI) 6-3

interrupts (continued)

- optimizing performance 12-19
- physical characteristics 12-8
- posting 6-1, 6-6, 12-17
- priority handling 12-2
- priority-31 interrupts 6-3, 12-8
- programmable options 12-9
- requesting 12-16
- restoring r3 12-8
- servicing 6-3, 12-17
- sysctl** 12-2
- vector caching 12-20

IP register, see Instruction Pointer (IP) register

IP with Displacement 3-7

IPND register 12-14

IS (instruction scheduler) A-3

**L**

latency (interrupt servicing) 12-17

**ld\*** 9-44

**ld, ldl, ldt, ldq** 9-44

**lda** 9-46

**ldib, ldis** 9-44

**ldob, ldos** 9-44

leaf procedures 5-1

literal addressing and alignment 2-5

literals 2-1, 2-5

little endian 2-12, 11-24

Load and store instructions 10-1

load instructions 4-5, 9-44

load-and-lock mechanism 2-14, 4-22

local calls 5-2, 5-12, 7-2

- call** 5-2
- callx** 5-2

Local Register Cache 5-3, A-7

## INDEX

local registers 2-1, 5-2  
 allocation 2-3, 5-2  
 management 2-3  
 overview 1-7  
 usage 5-2

local stack 2-1

LOCK pin C-6

logical instructions 4-10

**M**

**mark** 9-47

MCON  
 external bus width 10-1

MCON0-15 registers 10-1, 10-6  
 I/O configuration A-13  
 memory region configuration 10-3

MDU (multiply/divide unit) A-7

memory access 11-2  
 non-burst and non-pipelined 11-13

memory address space 2-1  
 external memory requirements 2-10  
 atomic access 2-10  
 byte ordering  
 big endian 2-12  
 little endian 2-12  
 data alignment 2-11  
 data block sizes 2-11  
 data block storage 2-12  
 indivisible access 2-10  
 instruction alignment in external memory  
 2-11  
 reserved memory 2-10

location 2-9  
 management 2-9

memory addressing modes  
 Absolute 3-6  
 examples 3-7  
 Index with Displacement 3-7  
 IP with Displacement 3-7  
 Register Indirect 3-6

memory region configuration (MCON) table 10-1

memory region control registers (MCON 0-15) 10-6

memory regions (A31:28) 10-3

memory request 11-1

Micro-flows  
 atomic instructions A-42  
 bit and bit field instructions A-39  
 branch instructions A-40  
 call and return instructions A-41  
 comparison instructions A-40  
 data movement instructions A-38  
 debug instructions A-42  
 definition A-15  
 execution A-38  
 fault instructions A-42  
 invocation A-37  
 processor management instructions A-42

**modac** 9-48

**modi** 9-49

**modify** 9-50

modify-trace-controls (**modtc**) instruction 8-2

**modpc** 9-51

**modtc** 9-52

**mov\*** 9-53

**mov, movl, movt, movq** 9-53

move instructions 9-53

**mul\*** 9-54

**muli, mulo** 9-54

multiple fault conditions 7-9

Multiply/Divide Unit (MDU) A-7, A-22



**N**

**nand** 9-55  
 NIF bit 7-14, 7-19  
 NMI 12-7  
 no-imprecise-faults (NIF) bit 7-14  
 non-maskable interrupt (NMI) 6-3, 12-7, 12-9  
**nor** 9-56  
**not, notand** 9-57  
**notbit** 9-58  
**notor** 9-59  
 $N_{RAD}$  10-4, 11-5  
 $N_{RDD}$  10-4, 11-5  
 $N_{WAD}$  10-4, 11-5  
 $N_{WDD}$  10-4, 11-5  
 $N_{XDA}$  10-4, 11-5

**O**

ONCE 14-1, 14-5  
 on-circuit emulation (ONCE) 14-1, 14-5  
 one-X mode 14-26  
**or, ornot** 9-60  
 ordinals 3-3  
   sign and sign extension 3-3  
   sizes 3-3  
 output pins 14-28

**P**

parallel instruction execution  
   overview 1-1  
 Parallel Issue A-14  
 parallel processing A-14  
   parallel execution A-15  
 parameter passing 5-10  
   argument list 5-10  
   by reference 5-10  
   by value 5-10  
 PC register, see Process Controls (PC) register 2-17

pending interrupts 6-5  
   encoding 6-5  
   interrupt procedure pointer 6-5  
   pending priorities field 6-5  
 PFP (Previous Frame Pointer - r0) 5-4, 5-16  
 Pipeline Stalls  
   register bypassing A-19  
   register scoreboarding A-18  
 pipelined read accesses 10-3, 11-21  
 posting interrupts 6-6  
   atomic modify operations 6-7  
   external agents 6-7  
   hardware-requested interrupts 6-6  
   software-requested interrupts 6-6  
   **sysctl** 6-7  
 power and ground planes 14-27  
 PRCB 14-8  
 prereturn-trace mode 8-5  
 Previous Frame Pointer (PFP) 5-4, 5-16  
   location 2-3  
 priority-31 interrupts 6-3, 12-8  
 procedure calls  
   branch-and-link 5-1  
   call and return mechanism 5-1  
   leaf procedures 5-1  
   overview 1-3  
 procedure stack 5-3  
   growth 5-3  
 Process Controls (PC) register 2-17  
   execution mode flag 2-17  
   initialization 2-19  
   modification 2-19  
   **modpc** 2-19  
   priority field 2-18  
   processor state flag 2-18  
   trace enable bit 2-19  
   trace fault pending flag 2-19



# INDEX

- Processing Units A-20
  - Address Generation Unit A-25
  - Bus Control Unit A-26
  - Data RAM A-24
  - Execution Unit A-20
  - Multiply/Divide Unit A-22
- processor control block 2-1, 2-8
- processor initialization 14-1
- processor management instructions 4-18
- processor state registers 2-1, 2-14
  - Arithmetic Controls (AC) register 2-15
  - Instruction Pointer (IP) register 2-15
  - Process Controls (PC) register 2-17
  - Trace Controls (TC) register 2-20

**R**

- r0 (Previous Frame Pointer) 5-16
- register addressing and alignment 2-5
- register bypassing A-7
- register cache 2-1, 5-9
  - size 5-9
- Register File (RF) A-6
  - CTRL units A-15
  - MEM A-6
  - MEM units A-15
  - REG A-6
  - REG units A-15
- Register Indirect 3-6
  - register-indirect-with-displacement 3-7
  - register-indirect-with-index 3-7
  - register-indirect-with-index-and-displacement 3-7
  - register-indirect-with-offset 3-7
- register scoreboarding 2-4, A-5, A-18
  - common application 2-4
  - example 2-5
  - implementation 2-4

- registers
  - naming conventions 1-7
- remi, remo** 9-61
- reserved locations C-4
- reserved memory 1-6
- resource scoreboarding A-5, A-18
- ret** 9-62
- Return Instruction Pointer (RIP) 5-5
  - location 2-3
- return operation 5-6
- return type field 5-4
- RF (register file) A-6
- RIP (Return Instruction Pointer - r2) 5-4
- rotate** 9-64

**S**

- SALIGN C-3
- scanbit** 9-65
- scanbyte** 9-66
- Scoreboarding A-17
  - register scoreboarding A-18
  - resource scoreboarding A-18
- sdma** 9-67, 13-24
- setbit** 9-68
- SFRs, see special function registers 2-1
- sh\*** 9-69
- shift instructions 9-69
- shli, shri, shrdi** 9-69
- shlo, shro** 9-69
- six-port register file A-6
- SP (Stack Pointer - r1) 5-4
- spanbit** 9-72



special function registers (SFRs) 2-1, 2-4, 9-4

- access to 2-4
- data cache (CF only) 2-4
- overview 1-7
- reading or modifying 2-4
- usage 2-4

SRAM interface B-1

SRAM A-7

**st\*** 9-73

**st, stl, stt, stq** 9-73

stack frame

- allocation 5-2

Stack Pointer (SP) 5-4

- location 2-3

Static RAM A-7

**stib, stis** 9-73

**stob, stos** 9-73

store instructions 4-5, 9-73

**sub\*** 9-76

**subc** 9-75

**subi, subo** 9-76

supervisor calls 5-2

supervisor mode resources 2-20

supervisor pin 2-20

supervisor stack 2-1, 2-8

supervisor-trace mode 8-4

**syncf** 7-19, 9-77

**sysctl** 4-21, 9-78

system calls 5-2, 5-12

- calls 5-2
- system-local calls 5-2
- system-supervisor calls 5-2

system control functions 4-19

- sysctl** instruction syntax 4-19
- system control messages 4-20
  - configure instruction cache 4-21
  - invalidate cache 4-21
  - load control registers 4-23
  - reinitialize processor 4-22
  - request interrupt 4-21

system procedure table 2-1, 2-8

- initialization 14-11

system-local call 7-2

system-supervisor call 7-2

**T**

test instructions 9-81

**test\*** 9-81

**teste, testne, testl, testle** 9-81

**testg, testge** 9-81

**testo, testno** 9-81

three-state output pins 14-28

Trace Controls (TC) register 2-20, 8-2

trace events 8-1

- hardware breakpoint registers 8-1
- mark and fmark 8-1
- PC and TC registers 8-1

trace-fault-pending flag 8-3

TTL input pins 14-29

two-X mode 14-26

**U**

**udma** 9-83

unaligned DMA transfers 13-10

user stack 2-8

user supervisor protection model 2-20

- supervisor mode resources 2-20
- usage 2-21

## INDEX

### V

vector entries 6-4

$\overline{\text{NMI}}$  6-5

    structure 6-5

### W

wait states

    programmable wait state generator 10-2

warm reset 12-15, 14-2

write policy A-10

### X

**xnor, xor** 9-84





G

INSTRUCTION SET QUICK  
REFERENCE KEY

I





# APPENDIX A INSTRUCTION SET QUICK REFERENCE KEY

For each instruction, this quick reference lists mnemonic, name, assembler syntax, action, opcode, instruction format, machine type and execution time.

- Mnemonic* The acronym recommended for use by i960<sup>®</sup> processor assemblers.
- Name* A descriptive name for the instruction.
- Assembler Syntax* The recommended operand ordering and syntax for i960 processor assemblers.
- Action* An abbreviated algorithmic description of the action that the instruction performs, including modification to the AC, PC or TC registers. Any possible faults generated are also listed. Table A-1 describes the meaning of the shorthand used in the register and fault sections of the reference.

**Table A-1. Action Shorthand**

| Symbol | Definition  | Symbol | Definition       |
|--------|---|--------|------------------|
| —      | Not changed or generated by the instruction.            | C      | Call             |
| 0      | Set to 0 by the instruction under any condition.        | S      | Supervisor       |
| 1      | Set to 1 by the instruction under any condition.        | BR     | Breakpoint       |
| ÷      | May be set or cleared by the instruction.               | R      | Return           |
| ∅      | May be cleared – but is never set – by the instruction. | P      | Prereturn        |
| ‡      | May be set – but is never cleared – by the instruction. | U      | Unimplemented    |
| T      | Trace Fault Type  | OP     | Invalid Operand  |
| O      | Operation Fault Type                                    | OC     | Invalid Opcode   |
| A      | Arithmetic Fault Type                                   | IO     | Integer Overflow |
| C      | Constraint Fault Type                                   | ZD     | Zero Divide      |
| P      | Privilege Fault Type                                    | M      | Machine          |
| Y      | Type Fault Type   | R      | Range            |
| I      | Instruction   | ?      | Undefined        |
| B      | Branch  |        |                  |



- Opcode*                    The instruction’s opcode.
- Instruction Format*      The encoding format of the instruction. Appendix D details the complete encoding for each instruction.
- Machine Type*            Indicates which group of parallel processing units are used to execute the instruction. Table A-2 lists the possible machine types.

**Table A-2. Machine Type Shorthand**

| Symbol | Definition   |
|--------|--|
| R      | <b>Register</b> — The instruction is executed in parallel by a processing unit on the Register side of the processor.                              |
| M      | <b>Memory</b> — The instruction is executed in parallel by a processing unit on the Memory side of the processor.                                  |
| C      | <b>Control</b> — The instruction is executed by the Instruction Scheduler, in parallel with other R- or M-type instructions.                       |
| μ      | <b>Micro-flow</b> — The processor performs this instruction by issuing a sequence of R-, M- and/or C-type instructions stored in its internal ROM. |

*Execution Time*            The instruction’s execution time is listed in two ways: Instruction Issue and Result Latency. These times are not additive; they represent a range — from minimum to maximum — within which actual execution time will fall.

Instruction Issue time is the number of clocks the instruction uses when there are no register or resource dependencies to slow it down. Back-to-back instructions with no dependencies execute at the instruction issue rate.

Result Latency is the length of time that an instruction uses to complete once it begins. Back-to-back instructions which are dependent upon each other execute at the Result Latency rate.

In the Instruction Execution column, a range of numbers (e.g., 0.5-1) indicates either the degree of parallel instruction issue achieved or conditions specific to the instruction’s run-time execution (such as branch taken or not taken). Table A-3 describes the shorthand for additive factors that appear in the execution time columns.



**Table A-3. Execution Times Shorthand for Additive Factors**

|        |  |                        |
|--------|--|------------------------|
| efa    | The time for effective address calculation.  |                        |
|        | For the <i>lda</i> instruction, <i>efa</i> =   | <b>#clocks</b>         |
|        |  | <b>Addressing Mode</b> |
|        | 0  | offset                 |
|        | 0  | disp                   |
|        | 0  | (reg)                  |
|        | 0  | offset(reg)            |
|        | 0  | disp(reg)              |
|        | 0  | disp[reg * scale]      |
|        | 1  | (reg)[reg * scale]     |
|        | 1  | disp(reg)[reg * scale] |
|        | 3  | disp+8(IP)             |
|        | For all other references, <i>efa</i> =   | <b>#clocks</b>         |
|        |  | <b>Addressing Mode</b> |
|        | 0  | offset                 |
| 0      | disp   |                        |
| 0      | (reg)  |                        |
| 1      | offset(reg)  |                        |
| 1      | disp(reg)  |                        |
| 1      | disp[reg * scale]  |                        |
| 2      | (reg)[reg * scale]   |                        |
| 2      | disp(reg)[reg * scale]   |                        |
| 4      | disp+8(IP)   |                        |
| bus    | The time necessary to perform the <i>external</i> memory operations associated with the instruction. The additive factor <i>bus</i> equals 0 when memory operations associated with the instruction are in the on-chip data RAM. <i>Bus</i> is also equal to zero for branches and calls where the target is in the instruction cache. |                        |
| spill  | The time required to write one cached register set to its reserved frame on the stack. Although <i>spill</i> is a function of <i>bus</i> , <i>spill</i> equals 36 when the stack is in external zero wait state memory.  |                        |
| fill   | The time required to read one register set from the previous stack frame. Although <i>fill</i> is a function of <i>bus</i> , <i>fill</i> equals 36 when the stack is in external zero wait state memory.   |                        |
| frames | The number of register sets flushed to memory.   |                        |
| fixup  | When the <i>shrdi</i> instruction concludes, a four clock micro-flow executes if any bits shifted out were set and the source operand was negative. <i>Fixup</i> is four clocks for this case. <i>Fixup</i> is zero clocks for positive operands and for negative operands in which only zeros are shifted out.                        |                        |







**i960<sup>®</sup> Cx Microprocessor**  
**Instruction Set Quick Reference**



March 1994  
Order Number 272220-002

**i960<sup>®</sup> Cx Microprocessor User's Guide — Instruction Set Quick Reference**

For each instruction, this quick reference lists mnemonic, name, assembler syntax, action, opcode, instruction format, machine type and execution time.

- Mnemonic*            The acronym recommended for use by i960<sup>®</sup> processor assemblers.
- Name*                 A descriptive name for the instruction.
- Assembler Syntax*    The recommended operand ordering and syntax for i960 processor assemblers.
- Action*                An abbreviated algorithmic description of the action that the instruction performs, including modification to the AC, PC or TC registers. Any possible faults generated are also listed. Table 1 describes the meaning of the shorthand used in the register and fault sections of the reference.

**Table 1. Action Shorthand**

| Symbol | Definition  | Symbol | Definition       |
|--------|---|--------|------------------|
| —      | Not changed or generated by the instruction.            | C      | Call             |
| 0      | Set to 0 by the instruction under any condition.        | S      | Supervisor       |
| 1      | Set to 1 by the instruction under any condition.        | BR     | Breakpoint       |
| ÷      | May be set or cleared by the instruction.               | R      | Return           |
| ∅      | May be cleared – but is never set – by the instruction. | P      | Prereturn        |
| !      | May be set – but is never cleared – by the instruction. | U      | Unimplemented    |
| T      | Trace Fault Type  | OP     | Invalid Operand  |
| O      | Operation Fault Type                                    | OC     | Invalid Opcode   |
| A      | Arithmetic Fault Type                                   | IO     | Integer Overflow |
| C      | Constraint Fault Type                                   | ZD     | Zero Divide      |
| P      | Privilege Fault Type                                    | M      | Machine          |
| Y      | Type Fault Type   | R      | Range            |
| I      | Instruction   | ?      | Undefined        |
| B      | Branch  |        |                  |

- Opcode* The instruction's opcode.
- Instruction Format* The encoding format of the instruction. Appendix D details the complete encoding for each instruction.
- Machine Type* Indicates which group of parallel processing units are used to execute the instruction. Table 2 lists the possible machine types.

**Table 2. Machine Type Shorthand**

| Symbol | Definition   |
|--------|--|
| R      | <b>Register</b> — The instruction is executed in parallel by a processing unit on the Register side of the processor.                              |
| M      | <b>Memory</b> — The instruction is executed in parallel by a processing unit on the Memory side of the processor.                                  |
| C      | <b>Control</b> — The instruction is executed by the Instruction Scheduler, in parallel with other R- or M-type instructions.                       |
| μ      | <b>Micro-flow</b> — The processor performs this instruction by issuing a sequence of R-, M- and/or C-type instructions stored in its internal ROM. |

- Execution Time* The instruction's execution time is listed in two ways: Instruction Issue and Result Latency. These times are not additive; they represent a range — from minimum to maximum — within which actual execution time will fall.
- Instruction Issue time is the number of clocks the instruction uses when there are no register or resource dependencies to slow it down. Back-to-back instructions with no dependencies execute at the instruction issue rate.
- Result Latency is the length of time that an instruction uses to complete once it begins. Back-to-back instructions which are dependent upon each other execute at the Result Latency rate.
- In the Instruction Execution column, a range of numbers (e.g., 0.5-1) indicates either the degree of parallel instruction issue achieved or conditions specific to the instruction's run-time execution (such as branch taken or not taken). Table 3 describes the shorthand for additive factors that appear in the execution time columns.

**Table 3. Execution Times Shorthand for Additive Factors**

| <p>efa</p>    | <p>The time for effective address calculation.<br/>For the <b>lda</b> instruction, <i>efa</i> =</p> <table border="1"> <thead> <tr> <th>#clocks</th> <th>Addressing Mode</th> </tr> </thead> <tbody> <tr><td>0</td><td>offset</td></tr> <tr><td>0</td><td>disp</td></tr> <tr><td>0</td><td>(reg)</td></tr> <tr><td>0</td><td>offset(reg)</td></tr> <tr><td>0</td><td>disp(reg)</td></tr> <tr><td>0</td><td>disp[reg * scale]</td></tr> <tr><td>1</td><td>(reg)[reg * scale]</td></tr> <tr><td>1</td><td>disp(reg)[reg * scale]</td></tr> <tr><td>3</td><td>disp+8(IP)</td></tr> </tbody> </table> | #clocks | Addressing Mode | 0 | offset | 0 | disp | 0 | (reg) | 0 | offset(reg) | 0 | disp(reg) | 0 | disp[reg * scale] | 1 | (reg)[reg * scale] | 1 | disp(reg)[reg * scale] | 3 | disp+8(IP) | <p>For all other references, <i>efa</i> =</p> <table border="1"> <thead> <tr> <th>#clocks</th> <th>Addressing Mode</th> </tr> </thead> <tbody> <tr><td>0</td><td>offset</td></tr> <tr><td>0</td><td>disp</td></tr> <tr><td>0</td><td>(reg)</td></tr> <tr><td>1</td><td>offset(reg)</td></tr> <tr><td>1</td><td>disp(reg)</td></tr> <tr><td>1</td><td>disp[reg * scale]</td></tr> <tr><td>2</td><td>(reg)[reg * scale]</td></tr> <tr><td>2</td><td>disp(reg)[reg * scale]</td></tr> <tr><td>4</td><td>disp+8(IP)</td></tr> </tbody> </table> | #clocks | Addressing Mode | 0 | offset | 0 | disp | 0 | (reg) | 1 | offset(reg) | 1 | disp(reg) | 1 | disp[reg * scale] | 2 | (reg)[reg * scale] | 2 | disp(reg)[reg * scale] | 4 | disp+8(IP) |
|---------------|---|---------|-----------------|---|--------|---|------|---|-------|---|-------------|---|-----------|---|-------------------|---|--------------------|---|------------------------|---|------------|---|---------|-----------------|---|--------|---|------|---|-------|---|-------------|---|-----------|---|-------------------|---|--------------------|---|------------------------|---|------------|
| #clocks       | Addressing Mode   |         |                 |   |        |   |      |   |       |   |             |   |           |   |                   |   |                    |   |                        |   |            |   |         |                 |   |        |   |      |   |       |   |             |   |           |   |                   |   |                    |   |                        |   |            |
| 0             | offset  |         |                 |   |        |   |      |   |       |   |             |   |           |   |                   |   |                    |   |                        |   |            |   |         |                 |   |        |   |      |   |       |   |             |   |           |   |                   |   |                    |   |                        |   |            |
| 0             | disp  |         |                 |   |        |   |      |   |       |   |             |   |           |   |                   |   |                    |   |                        |   |            |   |         |                 |   |        |   |      |   |       |   |             |   |           |   |                   |   |                    |   |                        |   |            |
| 0             | (reg)   |         |                 |   |        |   |      |   |       |   |             |   |           |   |                   |   |                    |   |                        |   |            |   |         |                 |   |        |   |      |   |       |   |             |   |           |   |                   |   |                    |   |                        |   |            |
| 0             | offset(reg)   |         |                 |   |        |   |      |   |       |   |             |   |           |   |                   |   |                    |   |                        |   |            |   |         |                 |   |        |   |      |   |       |   |             |   |           |   |                   |   |                    |   |                        |   |            |
| 0             | disp(reg)   |         |                 |   |        |   |      |   |       |   |             |   |           |   |                   |   |                    |   |                        |   |            |   |         |                 |   |        |   |      |   |       |   |             |   |           |   |                   |   |                    |   |                        |   |            |
| 0             | disp[reg * scale]   |         |                 |   |        |   |      |   |       |   |             |   |           |   |                   |   |                    |   |                        |   |            |   |         |                 |   |        |   |      |   |       |   |             |   |           |   |                   |   |                    |   |                        |   |            |
| 1             | (reg)[reg * scale]  |         |                 |   |        |   |      |   |       |   |             |   |           |   |                   |   |                    |   |                        |   |            |   |         |                 |   |        |   |      |   |       |   |             |   |           |   |                   |   |                    |   |                        |   |            |
| 1             | disp(reg)[reg * scale]  |         |                 |   |        |   |      |   |       |   |             |   |           |   |                   |   |                    |   |                        |   |            |   |         |                 |   |        |   |      |   |       |   |             |   |           |   |                   |   |                    |   |                        |   |            |
| 3             | disp+8(IP)  |         |                 |   |        |   |      |   |       |   |             |   |           |   |                   |   |                    |   |                        |   |            |   |         |                 |   |        |   |      |   |       |   |             |   |           |   |                   |   |                    |   |                        |   |            |
| #clocks       | Addressing Mode   |         |                 |   |        |   |      |   |       |   |             |   |           |   |                   |   |                    |   |                        |   |            |   |         |                 |   |        |   |      |   |       |   |             |   |           |   |                   |   |                    |   |                        |   |            |
| 0             | offset  |         |                 |   |        |   |      |   |       |   |             |   |           |   |                   |   |                    |   |                        |   |            |   |         |                 |   |        |   |      |   |       |   |             |   |           |   |                   |   |                    |   |                        |   |            |
| 0             | disp  |         |                 |   |        |   |      |   |       |   |             |   |           |   |                   |   |                    |   |                        |   |            |   |         |                 |   |        |   |      |   |       |   |             |   |           |   |                   |   |                    |   |                        |   |            |
| 0             | (reg)   |         |                 |   |        |   |      |   |       |   |             |   |           |   |                   |   |                    |   |                        |   |            |   |         |                 |   |        |   |      |   |       |   |             |   |           |   |                   |   |                    |   |                        |   |            |
| 1             | offset(reg)   |         |                 |   |        |   |      |   |       |   |             |   |           |   |                   |   |                    |   |                        |   |            |   |         |                 |   |        |   |      |   |       |   |             |   |           |   |                   |   |                    |   |                        |   |            |
| 1             | disp(reg)   |         |                 |   |        |   |      |   |       |   |             |   |           |   |                   |   |                    |   |                        |   |            |   |         |                 |   |        |   |      |   |       |   |             |   |           |   |                   |   |                    |   |                        |   |            |
| 1             | disp[reg * scale]   |         |                 |   |        |   |      |   |       |   |             |   |           |   |                   |   |                    |   |                        |   |            |   |         |                 |   |        |   |      |   |       |   |             |   |           |   |                   |   |                    |   |                        |   |            |
| 2             | (reg)[reg * scale]  |         |                 |   |        |   |      |   |       |   |             |   |           |   |                   |   |                    |   |                        |   |            |   |         |                 |   |        |   |      |   |       |   |             |   |           |   |                   |   |                    |   |                        |   |            |
| 2             | disp(reg)[reg * scale]  |         |                 |   |        |   |      |   |       |   |             |   |           |   |                   |   |                    |   |                        |   |            |   |         |                 |   |        |   |      |   |       |   |             |   |           |   |                   |   |                    |   |                        |   |            |
| 4             | disp+8(IP)  |         |                 |   |        |   |      |   |       |   |             |   |           |   |                   |   |                    |   |                        |   |            |   |         |                 |   |        |   |      |   |       |   |             |   |           |   |                   |   |                    |   |                        |   |            |
| <p>bus</p>    | <p>The time necessary to perform the <i>external</i> memory operations associated with the instruction. The additive factor <i>bus</i> equals 0 when memory operations associated with the instruction are in the on-chip data RAM. <i>Bus</i> is also equal to zero for branches and calls where the target is in the instruction cache.</p>   |         |                 |   |        |   |      |   |       |   |             |   |           |   |                   |   |                    |   |                        |   |            |   |         |                 |   |        |   |      |   |       |   |             |   |           |   |                   |   |                    |   |                        |   |            |
| <p>spill</p>  | <p>The time required to write one cached register set to its reserved frame on the stack. Although <i>spill</i> is a function of <i>bus</i>, <i>spill</i> equals 36 when the stack is in external zero wait state memory.</p>   |         |                 |   |        |   |      |   |       |   |             |   |           |   |                   |   |                    |   |                        |   |            |   |         |                 |   |        |   |      |   |       |   |             |   |           |   |                   |   |                    |   |                        |   |            |
| <p>fill</p>   | <p>The time required to read one register set from the previous stack frame. Although <i>fill</i> is a function of <i>bus</i>, <i>fill</i> equals 36 when the stack is in external zero wait state memory.</p>  |         |                 |   |        |   |      |   |       |   |             |   |           |   |                   |   |                    |   |                        |   |            |   |         |                 |   |        |   |      |   |       |   |             |   |           |   |                   |   |                    |   |                        |   |            |
| <p>frames</p> | <p>The number of register sets flushed to memory.</p>   |         |                 |   |        |   |      |   |       |   |             |   |           |   |                   |   |                    |   |                        |   |            |   |         |                 |   |        |   |      |   |       |   |             |   |           |   |                   |   |                    |   |                        |   |            |
| <p>fixup</p>  | <p>When the <b>shrdi</b> instruction concludes, a four clock micro-flow executes if any bits shifted out were set and the source operand was negative. <i>Fixup</i> is four clocks for this case. <i>Fixup</i> is zero clocks for positive operands and for negative operands in which only zeros are shifted out.</p>  |         |                 |   |        |   |      |   |       |   |             |   |           |   |                   |   |                    |   |                        |   |            |   |         |                 |   |        |   |      |   |       |   |             |   |           |   |                   |   |                    |   |                        |   |            |

i960<sup>®</sup> Cx Microprocessor User's Guide — Instruction Set Quick Reference

| Mnemonic        | Description  | Arithmetic Controls |    |    |      |      |      | Process Controls |     |    |    | Trace Controls |       | Faults |    |   |   |   |      | Opcode | Opcode Format | Instruction Execution |                   |                |
|-----------------|--|---------------------|----|----|------|------|------|------------------|-----|----|----|----------------|-------|--------|----|---|---|---|------|--------|---------------|-----------------------|-------------------|----------------|
|                 |  | nif                 | om | of | cc 2 | cc 1 | cc 0 | p                | tfp | em | te | Events         | Modes | T      | O  | A | C | P | Y    |        |               | Mach. Type            | Instruction Issue | Result Latency |
| <b>addc</b>     | Add Ordinal with Carry<br>$src1, reg/lit/sfr$<br>$src2, reg/lit/sfr$<br>$dst, reg/sfr$<br>$dst \leftarrow src2 + src1 + AC.cc1$<br>$AC.cc0 \leftarrow$ integer overflow<br>$AC.cc1 \leftarrow$ carry out   | —                   | —  | —  | 0    | ÷    | ÷    | —                | ÷   | —  | —  | I              | —     | I      | U  | — | — | — | M    | 5B:0   | REG           | R                     | 0.5 - 1           | 1              |
| <b>addi</b>     | Add Integer<br>$src1, reg/lit/sfr$<br>$src2, reg/lit/sfr$<br>$dst, reg/sfr$<br>$dst \leftarrow src2 + src1$  | —                   | —  | ÷  | —    | —    | —    | ÷                | —   | —  | I  | —              | I     | U      | IO | — | — | — | M    | 59:1   | REG           | R                     | 0.5 - 1           | 1              |
| <b>addo</b>     | Add Ordinal<br>$src1, reg/lit/sfr$<br>$src2, reg/lit/sfr$<br>$dst, reg/sfr$<br>$dst \leftarrow src2 + src1$  | —                   | —  | —  | —    | —    | —    | ÷                | —   | —  | I  | —              | I     | U      | —  | — | — | M | 59:0 | REG    | R             | 0.5 - 1               | 1                 |                |
| <b>alterbit</b> | Alter Bit<br>$bitpos, reg/lit/sfr$<br>$src, reg/lit/sfr$<br>$dst, reg/sfr$<br>if (AC.cc1 = 1)<br>$dst \leftarrow src$ or $2^{bitpos \text{ mod } 32}$<br>else $dst \leftarrow src$ and not ( $2^{bitpos \text{ mod } 32}$ )  | —                   | —  | —  | —    | —    | —    | —                | —   | —  | I  | —              | I     | U      | —  | — | — | M | 58:F | REG    | R             | 0.5 - 1               | 1                 |                |
| <b>and</b>      | And<br>$src1, reg/lit/sfr$<br>$src2, reg/lit/sfr$<br>$dst, reg/sfr$<br>$dst \leftarrow src2$ and $src1$  | —                   | —  | —  | —    | —    | —    | ÷                | —   | —  | I  | —              | I     | U      | —  | — | — | M | 58:1 | REG    | R             | 0.5 - 1               | 1                 |                |
| <b>andnot</b>   | And Not<br>$src1, reg/lit/sfr$<br>$src2, reg/lit/sfr$<br>$dst, reg/sfr$<br>$dst \leftarrow src2$ and not( $src1$ )   | —                   | —  | —  | —    | —    | —    | ÷                | —   | —  | I  | —              | I     | U      | —  | — | — | M | 58:2 | REG    | R             | 0.5 - 1               | 1                 |                |
| <b>atadd</b>    | Atomic Add Ordinal<br>$src/dst, reg$<br>$src, reg/lit/sfr$<br>$dst, reg/sfr$<br>$dst \leftarrow$ memory( $src/dst$ and not(0x3))<br>memory( $src/dst$ and not(0x3)) $\leftarrow dst + src$<br>LOCK is asserted during the read and deasserted after the write is completed.  | —                   | —  | —  | —    | —    | —    | ÷                | —   | —  | I  | —              | I     | U      | —  | — | — | M | 61:2 | REG    | $\mu$         | 7 + wait              |                   |                |
| <b>atmod</b>    | Atomic Modify<br>$src, reg/lit/sfr$<br>$mask, reg/lit/sfr$<br>$src/dst, reg$<br>temp $\leftarrow$ memory( $src$ and not(0x3))<br>memory( $src$ and not(0x3)) $\leftarrow (src/dst$ and $mask)$ or (temp and not( $mask$ ))<br>$src/dst \leftarrow$ temp<br>LOCK is asserted during the read and deasserted after the write is completed. | —                   | —  | —  | —    | —    | —    | ÷                | —   | —  | I  | —              | I     | U      | —  | — | — | M | 61:0 | REG    | m             | 8 + wait              |                   |                |
| <b>b</b>        | Branch<br>$targ$<br>IP $\leftarrow targ$   | —                   | —  | —  | —    | —    | —    | ÷                | —   | —  | IB | —              | IB    | U      | —  | — | — | — | 08   | CTRL   | C             | 0 - 2                 | 2                 |                |

i960<sup>®</sup> Cx Microprocessor User's Guide — Instruction Set Quick Reference

| Mnemonic    | Description   | Arithmetic Controls |    |    |      |      |      | Process Controls |     |    |    | Trace Controls |       | Faults |               |   |   |   |   | Opcode | Opcode Format | Instruction Execution |                   |                |
|-------------|---|---------------------|----|----|------|------|------|------------------|-----|----|----|----------------|-------|--------|---------------|---|---|---|---|--------|---------------|-----------------------|-------------------|----------------|
|             |   | nif                 | om | of | cc 2 | cc 1 | cc 0 | p                | tfp | em | te | Events         | Modes | T      | O             | A | C | P | Y |        |               | Mach. Type            | Instruction Issue | Result Latency |
| <b>bal</b>  | Branch and Link<br><i>targ</i><br>g14 ← next IP<br>IP ← <i>targ</i>   | —                   | —  | —  | —    | —    | —    | —                | ÷   | —  | —  | IB             | —     | IB     | U             | — | — | — | — | 0B     | CTRL          | C                     | 1 - 2             | 2              |
| <b>balx</b> | Branch And Link Extended<br><i>targ</i> , <i>dst</i><br><i>mem</i> , <i>reg</i><br><i>dst</i> ← next IP<br>IP ← <i>targ</i>   | —                   | —  | —  | —    | —    | —    | —                | ÷   | —  | —  | IB             | —     | I      | OP<br>U<br>OC | — | — | — | — | 85     | MEM           | μ                     | 4 - 6             | 4 - 6          |
| <b>bbc</b>  | Check Bit and Branch If Clear<br><i>bitpos</i> , <i>src</i> , <i>targ</i><br><i>reg/lit/sfr</i> , <i>reg</i><br>AC.cc1 ← ( <i>src</i> and 2 <sup>(<i>bitpos</i> mod 32)</sup> )<br>if (AC.cc1 = 0) IP ← <i>targ</i> | —                   | —  | —  | 0    | ÷    | 0    | —                | ÷   | —  | —  | IB             | —     | IB     | U             | — | — | — | M | 30     | COBR          | C                     | 1 - 3             | 3              |
| <b>bbs</b>  | Check Bit and Branch If Set<br><i>bitpos</i> , <i>src</i> , <i>targ</i><br><i>reg/lit/sfr</i> , <i>reg</i><br>AC.cc1 ← ( <i>src</i> and 2 <sup>(<i>bitpos</i> mod 32)</sup> )<br>if (AC.cc1 = 1) IP ← <i>targ</i>   | —                   | —  | —  | 0    | ÷    | 0    | —                | ÷   | —  | —  | IB             | —     | IB     | U             | — | — | — | M | 37     | COBR          | C                     | 1 - 3             | 3              |
| <b>be</b>   | Branch If Equal<br><i>targ</i><br>if ((AC.cc and 010) ≠ 0) IP ← <i>targ</i>   | —                   | —  | —  | —    | —    | —    | —                | ÷   | —  | —  | IB             | —     | IB     | U             | — | — | — | — | 12     | CTRL          | C                     | 0 - 2             | 2              |
| <b>bg</b>   | Branch If Greater<br><i>targ</i><br>if ((AC.cc and 001) ≠ 0) IP ← <i>targ</i>   | —                   | —  | —  | —    | —    | —    | —                | ÷   | —  | —  | IB             | —     | IB     | U             | — | — | — | — | 11     | CTRL          | C                     | 0 - 2             | 2              |
| <b>bge</b>  | Branch If Greater Or Equal<br><i>targ</i><br>if ((AC.cc and 011) ≠ 0) IP ← <i>targ</i>  | —                   | —  | —  | —    | —    | —    | —                | ÷   | —  | —  | IB             | —     | IB     | U             | — | — | — | — | 13     | CTRL          | C                     | 0 - 2             | 2              |
| <b>bl</b>   | Branch If Less<br><i>targ</i><br>if ((AC.cc and 100) ≠ 0) IP ← <i>targ</i>  | —                   | —  | —  | —    | —    | —    | —                | ÷   | —  | —  | IB             | —     | IB     | U             | — | — | — | — | 14     | CTRL          | C                     | 0 - 2             | 2              |
| <b>ble</b>  | Branch If Less Or Equal<br><i>targ</i><br>if ((AC.cc and 110) ≠ 0) IP ← <i>targ</i>   | —                   | —  | —  | —    | —    | —    | —                | ÷   | —  | —  | IB             | —     | IB     | U             | — | — | — | — | 16     | CTRL          | C                     | 0 - 2             | 2              |
| <b>bne</b>  | Branch If Not Equal<br><i>targ</i><br>if ((AC.cc and 101) ≠ 0) IP ← <i>targ</i>   | —                   | —  | —  | —    | —    | —    | —                | ÷   | —  | —  | IB             | —     | IB     | U             | — | — | — | — | 15     | CTRL          | C                     | 0 - 2             | 2              |
| <b>bno</b>  | Branch If Not Ordered<br><i>targ</i><br>if (AC.cc = 000) IP ← <i>targ</i>   | —                   | —  | —  | —    | —    | —    | —                | ÷   | —  | —  | IB             | —     | IB     | U             | — | — | — | — | 10     | CTRL          | C                     | 0 - 2             | 2              |
| <b>bo</b>   | Branch If Ordered<br><i>targ</i><br>if (AC.cc ≠ 0) IP ← <i>targ</i>   | —                   | —  | —  | —    | —    | —    | —                | ÷   | —  | —  | IB             | —     | IB     | U             | — | — | — | — | 17     | CTRL          | C                     | 0 - 2             | 2              |
| <b>bx</b>   | Branch Extended<br><i>targ</i> , <i>mem</i><br>IP ← <i>targ</i>   | —                   | —  | —  | —    | —    | —    | —                | ÷   | —  | —  | IB             | —     | IB     | OP<br>U<br>OC | — | — | — | — | 84     | MEM           | μ                     | 4 - 6             | 4 - 6          |

i960<sup>®</sup> Cx Microprocessor User's Guide — Instruction Set Quick Reference

| Mnemonic       | Description   | Arithmetic Controls |    |    |      |      |      | Process Controls |     |    |     | Trace Controls |       | Faults        |   |   |   |   |      | Opcode | Opcode Format | Instruction Execution |                   |                |
|----------------|---|---------------------|----|----|------|------|------|------------------|-----|----|-----|----------------|-------|---------------|---|---|---|---|------|--------|---------------|-----------------------|-------------------|----------------|
|                |   | nif                 | om | of | cc 2 | cc 1 | cc 0 | p                | tfp | em | te  | Events         | Modes | T             | O | A | C | P | Y    |        |               | Mach. Type            | Instruction Issue | Result Latency |
| <b>call</b>    | Call<br><i>targ</i><br><i>disp</i><br>RIP ← next IP<br>temp ← (sp + 0x10) and not (0xf)<br>memory (fp) ← r0:15 /* accesses are cached in local register cache */<br>PPF ← FP<br>PPF.rt ← 000<br>FP ← temp<br>SP ← FP + 64<br>IP ← <i>targ</i>                                     | —                   | —  | —  | —    | —    | —    | ÷                | —   | —  | IC  | —              | IC    | —             | — | — | — | — | 09   | CTRL   | μ             | 4 + spill             | 4 + spill         |                |
| <b>calls</b>   | Call System<br><i>src</i><br>reg/lit/sfr<br>if ( <i>src</i> > 259) Protection-length fault<br>if (local call or PC.cm = 1)<br>{ Perform Local Call using SPT }<br>else { Perform Supervisor Call using SPT }  | —                   | —  | —  | —    | —    | —    | ÷                | ÷   | ÷  | ICS | —              | ICS   | U             | — | — | L | M | 66:0 | REG    | μ             | 38 - 56 + spill       | 38 - 56 + spill   |                |
| <b>callx</b>   | Call Extended<br><i>targ</i><br><i>mem</i><br>rip ← next IP<br>temp ← (sp + 0x10) and not (0xf)<br>memory (fp) ← r0:15 /* accesses are cached in local register cache */<br>PPF ← FP<br>PPF.rt ← 000<br>FP ← temp<br>SP ← fp + 64<br>IP ← <i>targ</i>                             | —                   | —  | —  | —    | —    | —    | ÷                | —   | —  | IC  | —              | IC    | OP<br>U<br>OC | — | — | — | — | 86   | MEM    | μ             | 7 - 9 + spill         | 7 - 9 + spill     |                |
| <b>chkbit</b>  | Check Bit<br><i>bitpos, src</i><br>reg/lit/sfr reg/lit/sfr<br>if ( <i>src</i> and 2 <sup>(<i>bitpos</i> mod 32)</sup> = 0)<br>AC.cc1 ← 0;<br>else AC.cc1 ← 1;   | —                   | —  | —  | 0    | ÷    | 0    | —                | ÷   | —  | I   | —              | I     | U             | — | — | — | M | 5A:E | REG    | R             | 0.5 - 1               | 1                 |                |
| <b>clrbit</b>  | Clear Bit<br><i>bitpos, src, dst</i><br>reg/lit/sfr reg/lit/sfr reg/sfr<br><i>dst</i> ← <i>src</i> and not(2 <sup>(<i>bitpos</i> mod 32)</sup> )  | —                   | —  | —  | —    | —    | —    | ÷                | —   | —  | I   | —              | I     | U             | — | — | — | M | 58:C | REG    | R             | 0.5 - 1               | 1                 |                |
| <b>cmpdeci</b> | Compare and Decrement Integer<br><i>src1, src2, dst</i><br>reg/lit/sfr reg/lit/sfr reg/sfr<br>if ( <i>src1</i> < <i>src2</i> ) AC.cc ← 100;<br>else if ( <i>src1</i> = <i>src2</i> ) AC.cc ← 010;<br>else AC.cc ← 001;<br><i>dst</i> ← <i>src2</i> - 1; /* overflow is ignored */ | —                   | —  | —  | ÷    | ÷    | ÷    | —                | ÷   | —  | I   | —              | I     | U             | — | — | — | M | 5A:7 | REG    | R             | 0.5 - 1               | 1                 |                |
| <b>cmpdeco</b> | Compare and Decrement Ordinal<br><i>src1, src2, dst</i><br>reg/lit/sfr reg/lit/sfr reg/sfr<br>if ( <i>src1</i> < <i>src2</i> ) AC.cc ← 100;<br>else if ( <i>src1</i> = <i>src2</i> ) AC.cc ← 010;<br>else AC.cc ← 001;<br><i>dst</i> ← <i>src2</i> - 1;                           | —                   | —  | —  | ÷    | ÷    | ÷    | —                | ÷   | —  | I   | —              | I     | U             | — | — | — | M | 5A:6 | REG    | R             | 0.5 - 1               | 1                 |                |



i960<sup>®</sup> Cx Microprocessor User's Guide — Instruction Set Quick Reference

| Mnemonic       | Description  | Arithmetic Controls |    |    |      |      |      | Process Controls |     |    |    | Trace Controls |       | Faults |   |   |   |   |   | Opcode | Opcode Format | Instruction Execution |                   |                |
|----------------|--|---------------------|----|----|------|------|------|------------------|-----|----|----|----------------|-------|--------|---|---|---|---|---|--------|---------------|-----------------------|-------------------|----------------|
|                |  | nif                 | om | of | cc 2 | cc 1 | cc 0 | p                | tfp | em | te | Events         | Modes | T      | O | A | C | P | Y |        |               | Mach. Type            | Instruction Issue | Result Latency |
| <b>cmpi</b>    | Compare Integer<br><i>src1</i> , <i>src2</i><br>reg/lit/sfr reg/lit/sfr  | —                   | —  | —  | ÷    | ÷    | ÷    | —                | ÷   | —  | —  | I              | —     | I      | U | — | — | — | M | 5A:1   | REG           | R                     | 0.5 - 1           | 1              |
|                | if ( <i>src1</i> < <i>src2</i> ) AC.cc ← 100;<br>else if ( <i>src2</i> = <i>src2</i> ) AC.cc ← 010;<br>else AC.cc ← 001;                                       |                     |    |    |      |      |      |                  |     |    |    |                |       |        |   |   |   |   |   |        |               |                       |                   |                |
| <b>cmpibe</b>  | Compare Integer and Branch If Equal<br><i>src1</i> , <i>src2</i> , <i>targ</i><br>reg/lit/sfr reg reg  | —                   | —  | —  | ÷    | ÷    | ÷    | —                | ÷   | —  | —  | IB             | —     | IB     | U | — | — | — | M | 3A     | COBR          | C                     | 1 - 3             | 1 - 3          |
|                | if ( <i>src1</i> < <i>src2</i> ) AC.cc ← 100;<br>else if ( <i>src1</i> = <i>src2</i> ) AC.cc ← 010, IP ← <i>targ</i> ;<br>else AC.cc ← 001;                    |                     |    |    |      |      |      |                  |     |    |    |                |       |        |   |   |   |   |   |        |               |                       |                   |                |
| <b>cmpibg</b>  | Compare Integer and Branch If Greater<br><i>src1</i> , <i>src2</i> , <i>targ</i><br>reg/lit/sfr reg reg  | —                   | —  | —  | ÷    | ÷    | ÷    | —                | ÷   | —  | —  | IB             | —     | IB     | U | — | — | — | M | 39     | COBR          | C                     | 1 - 3             | 1 - 3          |
|                | if ( <i>src1</i> < <i>src2</i> ) AC.cc ← 100;<br>else if ( <i>src1</i> = <i>src2</i> ) AC.cc ← 010;<br>else AC.cc ← 001, IP ← <i>targ</i> ;                    |                     |    |    |      |      |      |                  |     |    |    |                |       |        |   |   |   |   |   |        |               |                       |                   |                |
| <b>cmpibl</b>  | Compare Integer and Branch If Less<br><i>src1</i> , <i>src2</i> , <i>targ</i><br>reg/lit/sfr reg reg   | —                   | —  | —  | ÷    | ÷    | ÷    | —                | ÷   | —  | —  | IB             | —     | IB     | U | — | — | — | M | 3C     | COBR          | C                     | 1 - 3             | 1 - 3          |
|                | if ( <i>src1</i> < <i>src2</i> ) AC.cc ← 100, IP ← <i>targ</i> ;<br>else if ( <i>src1</i> = <i>src2</i> ) AC.cc ← 010;<br>else AC.cc ← 001;                    |                     |    |    |      |      |      |                  |     |    |    |                |       |        |   |   |   |   |   |        |               |                       |                   |                |
| <b>cmpible</b> | Compare Integer and Branch If Less Or Equal<br><i>src1</i> , <i>src2</i> , <i>targ</i><br>reg/lit/sfr reg reg  | —                   | —  | —  | ÷    | ÷    | ÷    | —                | ÷   | —  | —  | IB             | —     | IB     | U | — | — | — | M | 3E     | COBR          | C                     | 1 - 3             | 1 - 3          |
|                | if ( <i>src1</i> < <i>src2</i> ) AC.cc ← 100, IP ← <i>targ</i> ;<br>else if ( <i>src1</i> = <i>src2</i> ) AC.cc ← 010, IP ← <i>targ</i> ;<br>else AC.cc ← 001; |                     |    |    |      |      |      |                  |     |    |    |                |       |        |   |   |   |   |   |        |               |                       |                   |                |
| <b>cmpibne</b> | Compare Integer and Branch If Not Equal<br><i>src1</i> , <i>src2</i> , <i>targ</i><br>reg/lit/sfr reg reg  | —                   | —  | —  | ÷    | ÷    | ÷    | —                | ÷   | —  | —  | IB             | —     | IB     | U | — | — | — | M | 3D     | COBR          | C                     | 1 - 3             | 1 - 3          |
|                | if ( <i>src1</i> < <i>src2</i> ) AC.cc ← 100, IP ← <i>targ</i> ;<br>else if ( <i>src1</i> = <i>src2</i> ) AC.cc ← 010;<br>else AC.cc ← 001, IP ← <i>targ</i> ; |                     |    |    |      |      |      |                  |     |    |    |                |       |        |   |   |   |   |   |        |               |                       |                   |                |
| <b>cmpibno</b> | Compare Integer and Branch If Not Ordered<br><i>src1</i> , <i>src2</i> , <i>targ</i><br>reg/lit/sfr reg reg  | —                   | —  | —  | ÷    | ÷    | ÷    | —                | ÷   | —  | —  | IB             | —     | IB     | U | — | — | — | M | 38     | COBR          | C                     | 1 - 3             | 1 - 3          |
|                | if ( <i>src1</i> < <i>src2</i> ) AC.cc ← 100;<br>else if ( <i>src1</i> = <i>src2</i> ) AC.cc ← 010;<br>else AC.cc ← 001;                                       |                     |    |    |      |      |      |                  |     |    |    |                |       |        |   |   |   |   |   |        |               |                       |                   |                |
| <b>cmpibo</b>  | Compare Integer and Branch If Ordered<br><i>src1</i> , <i>src2</i> , <i>targ</i><br>reg/lit/sfr reg reg  | —                   | —  | —  | ÷    | ÷    | ÷    | —                | ÷   | —  | —  | IB             | —     | IB     | U | — | — | — | M | 3F     | COBR          | C                     | 1 - 3             | 1 - 3          |
|                | if ( <i>src1</i> < <i>src2</i> ) AC.cc ← 100;<br>else if ( <i>src1</i> = <i>src2</i> ) AC.cc ← 010;<br>else AC.cc ← 001;<br>IP ← <i>targ</i>                   |                     |    |    |      |      |      |                  |     |    |    |                |       |        |   |   |   |   |   |        |               |                       |                   |                |

i960<sup>®</sup> Cx Microprocessor User's Guide — Instruction Set Quick Reference

| Mnemonic       | Description  | Arithmetic Controls |    |    |      |      |      | Process Controls |     |    |    | Trace Controls |       | Faults |   |   |   |   |   | Opcode | Opcode Format | Instruction Execution |                   |                |
|----------------|--|---------------------|----|----|------|------|------|------------------|-----|----|----|----------------|-------|--------|---|---|---|---|---|--------|---------------|-----------------------|-------------------|----------------|
|                |  | nif                 | om | of | cc 2 | cc 1 | cc 0 | p                | tfp | em | te | Events         | Modes | T      | O | A | C | P | Y |        |               | Mach. Type            | Instruction Issue | Result Latency |
| <b>cmpinci</b> | Compare and Increment Integer<br><i>src1</i> , <i>src2</i> , <i>dst</i><br>reg/lit/sfr reg/lit/sfr reg/sfr<br>if ( <i>src1</i> < <i>src2</i> ) AC.cc ← 100;<br>else if ( <i>src1</i> = <i>src2</i> ) AC.cc ← 010;<br>else AC.cc ← 001;<br><i>dst</i> ← <i>src2</i> +1; /* overflow is ignored */ | —                   | —  | —  | ÷    | ÷    | ÷    | —                | ÷   | —  | —  | I              | —     | I      | U | — | — | — | M | 5A:5   | REG           | R                     | 0.5 - 1           | 1              |
| <b>cmpinco</b> | Compare and Increment Ordinal<br><i>src1</i> , <i>src2</i> , <i>dst</i><br>reg/lit/sfr reg/lit/sfr reg/sfr<br>if ( <i>src1</i> < <i>src2</i> ) AC.cc ← 100;<br>else if ( <i>src1</i> = <i>src2</i> ) AC.cc ← 010;<br>else AC.cc ← 001;<br><i>dst</i> ← <i>src2</i> + 1;                          | —                   | —  | —  | ÷    | ÷    | ÷    | —                | ÷   | —  | —  | I              | —     | I      | U | — | — | — | M | 5A:4   | REG           | R                     | 0.5 - 1           | 1              |
| <b>cmpo</b>    | Compare Ordinal<br><i>src1</i> , <i>src2</i> ,<br>reg/lit/sfr reg/lit/sfr<br>if ( <i>src1</i> < <i>src2</i> ) AC.cc ← 100;<br>else if ( <i>src1</i> = <i>src2</i> ) AC.cc ← 010;<br>else AC.cc ← 001;  | —                   | —  | —  | ÷    | ÷    | ÷    | —                | ÷   | —  | —  | I              | —     | I      | U | — | — | — | M | 5A:0   | REG           | R                     | 0.5 - 1           | 1              |
| <b>cmpobe</b>  | Compare Ordinal and Branch If Equal<br><i>src1</i> , <i>src2</i> , <i>targ</i><br>reg/lit/sfr reg reg<br>if ( <i>src1</i> < <i>src2</i> ) AC.cc ← 100;<br>else if ( <i>src1</i> = <i>src2</i> ) AC.cc ← 010, IP ← <i>targ</i> ;<br>else AC.cc ← 001;   | —                   | —  | —  | ÷    | ÷    | ÷    | —                | ÷   | —  | —  | IB             | —     | IB     | U | — | — | — | M | 32     | COBR          | C                     | 1 - 3             | 1 - 3          |
| <b>cmpobg</b>  | Compare Ordinal and Branch If Greater<br><i>src1</i> , <i>src2</i> , <i>targ</i><br>reg/lit/sfr reg reg<br>if ( <i>src1</i> < <i>src2</i> ) AC.cc ← 100;<br>else if ( <i>src1</i> = <i>src2</i> ) AC.cc ← 010;<br>else AC.cc ← 001, IP ← <i>targ</i> ;   | —                   | —  | —  | ÷    | ÷    | ÷    | —                | ÷   | —  | —  | IB             | —     | IB     | U | — | — | — | M | 31     | COBR          | C                     | 1 - 3             | 1 - 3          |
| <b>cmpobl</b>  | Compare Ordinal and Branch If Less<br><i>src1</i> , <i>src2</i> , <i>targ</i><br>reg/lit/sfr reg reg<br>if ( <i>src1</i> < <i>src2</i> ) AC.cc ← 100, IP ← <i>targ</i> ;<br>else if ( <i>src1</i> = <i>src2</i> ) AC.cc ← 010;<br>else AC.cc ← 001;  | —                   | —  | —  | ÷    | ÷    | ÷    | —                | ÷   | —  | —  | IB             | —     | IB     | U | — | — | — | M | 34     | COBR          | C                     | 1 - 3             | 1 - 3          |
| <b>cmpoble</b> | Compare Ordinal and Branch If Less Or Equal<br><i>src1</i> , <i>src2</i> , <i>targ</i><br>reg/lit/sfr reg reg<br>if ( <i>src1</i> < <i>src2</i> ) AC.cc ← 100, IP ← <i>targ</i> ;<br>else if ( <i>src1</i> = <i>src2</i> ) AC.cc ← 010, IP ← <i>targ</i> ;<br>else AC.cc ← 001;                  | —                   | —  | —  | ÷    | ÷    | ÷    | —                | ÷   | —  | —  | IB             | —     | IB     | U | — | — | — | M | 36     | COBR          | C                     | 1 - 3             | 1 - 3          |
| <b>cmpobne</b> | Compare Ordinal and Branch If Not Equal<br><i>src1</i> , <i>src2</i> , <i>targ</i><br>reg/lit/sfr reg reg<br>if ( <i>src1</i> < <i>src2</i> ) AC.cc ← 100, IP ← <i>targ</i> ;<br>else if ( <i>src1</i> = <i>src2</i> ) AC.cc ← 010;<br>else AC.cc ← 001, IP ← <i>targ</i> ;                      | —                   | —  | —  | ÷    | ÷    | ÷    | —                | ÷   | —  | —  | IB             | —     | IB     | U | — | — | — | M | 35     | COBR          | C                     | 1 - 3             | 1 - 3          |

i960<sup>®</sup> Cx Microprocessor User's Guide — Instruction Set Quick Reference

| Mnemonic       | Description  | Arithmetic Controls |    |    |      |      |      | Process Controls |     |    |    | Trace Controls |       | Faults |   |          |   |   |   | Opcode | Opcode Format | Instruction Execution |                   |                   |
|----------------|--|---------------------|----|----|------|------|------|------------------|-----|----|----|----------------|-------|--------|---|----------|---|---|---|--------|---------------|-----------------------|-------------------|-------------------|
|                |  | nif                 | om | of | cc 2 | cc 1 | cc 0 | p                | tfp | em | te | Events         | Modes | T      | O | A        | C | P | Y |        |               | Mach. Type            | Instruction Issue | Result Latency    |
| <b>concmpi</b> | Conditional Compare Integer<br><i>src1</i> , <i>src2</i> ,<br>reg/lit/sfr reg/lit/sfr<br>if (AC.cc2 = 0)<br>{<br>if ( <i>src1</i> ≤ <i>src2</i> ) AC.cc ← 010;<br>else AC.cc ← 001;<br>}   | —                   | —  | —  | ÷    | ÷    | ÷    | —                | ÷   | —  | —  | I              | —     | I      | U | —        | — | — | M | 5A:3   | REG           | R                     | 0.5 - 1           | 1                 |
| <b>concmpo</b> | Conditional Compare Ordinal<br><i>src1</i> , <i>src2</i> ,<br>reg/lit/sfr reg/lit/sfr<br>if (AC.cc2 = 0)<br>{<br>if ( <i>src1</i> ≤ <i>src2</i> ) AC.cc ← 010;<br>else AC.cc ← 001;<br>}   | —                   | —  | —  | ÷    | ÷    | ÷    | —                | ÷   | —  | —  | I              | —     | I      | U | —        | — | — | M | 5A:2   | REG           | R                     | 0.5 - 1           | 1                 |
| <b>divi</b>    | Divide Integer<br><i>src1</i> , <i>src2</i> , <i>dst</i><br>reg/lit/sfr reg/lit/sfr reg/sfr<br>if ( <i>src1</i> = 0) Arithmetic Zero Divide fault<br><i>dst</i> ← quotient ( <i>src2</i> / <i>src1</i> )<br>/* <i>src2</i> , <i>src1</i> and <i>dst</i> are 32 bits */   | —                   | —  | —  | !    | —    | —    | —                | ÷   | —  | —  | I              | —     | I      | U | IO<br>ZD | — | — | M | 74:B   | REG           | m                     | 3                 | 37                |
| <b>divo</b>    | Divide Ordinal<br><i>src1</i> , <i>src2</i> , <i>dst</i><br>reg/lit/sfr reg/lit/sfr reg/sfr<br>if ( <i>src1</i> = 0) Arithmetic Zero Divide fault<br><i>dst</i> ← quotient ( <i>src2</i> / <i>src1</i> )<br>/* <i>src2</i> , <i>src1</i> and <i>dst</i> are 32 bits */   | —                   | —  | —  | —    | —    | —    | —                | ÷   | —  | —  | I              | —     | I      | U | ZD       | — | — | M | 70:B   | REG           | m                     | 3                 | 35,36             |
| <b>ediv</b>    | Extended Divide<br><i>src1</i> , <i>src2</i> , <i>dst</i><br>reg/lit/sfr reg/lit/sfr reg/sfr<br>if ( <i>src1</i> = 0) Arithmetic Zero Divide fault<br><i>dst</i> ← remainder ( <i>src2</i> / <i>src1</i> )<br><i>dst</i> + 1 ← quotient ( <i>src2</i> / <i>src1</i> )<br>/* <i>src2</i> is 64 bits; <i>src1</i> , <i>dst</i> and <i>dst</i> + 1 are 32 bits */ | —                   | —  | —  | —    | —    | —    | —                | ÷   | —  | —  | I              | —     | I      | U | ZD       | — | — | M | 67:1   | REG           | R                     | 3                 | 35,36             |
| <b>emul</b>    | Extended Multiply<br><i>src1</i> , <i>src2</i> , <i>dst</i><br>reg/lit/sfr reg/lit/sfr reg/sfr<br><i>dst</i> ← <i>src2</i> * <i>src1</i><br>/* <i>src2</i> and <i>src1</i> are 32 bits; <i>dst</i> is 64 bits */   | —                   | —  | —  | —    | —    | —    | —                | ÷   | —  | —  | I              | —     | I      | U | —        | — | — | M | 67:0   | REG           | R                     | 0.5 - 1           | 4                 |
| <b>eshro</b>   | Extended Shift Right Ordinal<br><i>src1</i> , <i>src2</i> , <i>dst</i><br>reg/lit/sfr reg/lit/sfr reg/sfr<br><i>dst</i> ← <i>src2</i> >> ( <i>src1</i> mod 32) /* <i>src2</i> is 64 bits */  | —                   | —  | —  | —    | —    | —    | —                | ÷   | —  | —  | I              | —     | I      | U | —        | — | — | M | 5D:8   | REG           | R                     | 0.5 - 1           | 1                 |
| <b>extract</b> | Extract<br><i>bitpos</i> , <i>len</i> , <i>src/dst</i><br>reg/lit/sfr reg/lit/sfr reg<br><i>src/dst</i> ← ( <i>src/dst</i> >> ( <i>bitpos</i> mod 32))<br>and (2 <sup><i>len</i></sup> mod 32) - 1)  | —                   | —  | —  | —    | —    | —    | —                | ÷   | —  | —  | I              | —     | I      | U | —        | — | — | M | 65:1   | REG           | μ                     | 4                 | 4                 |
| <b>faulte</b>  | Fault If Equal<br>if ((AC.cc and 010) ≠ 0)<br>Constraint Range fault   | —                   | —  | —  | —    | —    | —    | —                | ÷   | —  | —  | I              | —     | I      | U | —        | R | — | — | 1A     | CTRL          | μ                     | 1 - 2             | 99 if fault taken |

i960<sup>®</sup> Cx Microprocessor User's Guide — Instruction Set Quick Reference

| Mnemonic        | Description   | Arithmetic Controls |    |    |      |      |      | Process Controls |     |    |    | Trace Controls |       | Faults |               |   |   |   |   | Opcode | Opcode Format | Instruction Execution |                   |                   |
|-----------------|---|---------------------|----|----|------|------|------|------------------|-----|----|----|----------------|-------|--------|---------------|---|---|---|---|--------|---------------|-----------------------|-------------------|-------------------|
|                 |   | nif                 | om | of | cc 2 | cc 1 | cc 0 | p                | tfp | em | te | Events         | Modes | T      | O             | A | C | P | Y |        |               | Mach. Type            | Instruction Issue | Result Latency    |
| <b>faultg</b>   | Fault If Greater  | —                   | —  | —  | —    | —    | —    | —                | ÷   | —  | —  | I              | —     | I      | U             | — | R | — | — | 19     | CTRL          | μ                     | 1 - 2             | 99 if fault taken |
|                 | if (( AC.cc and 001) ≠ 0)<br>Constraint Range fault   | —                   | —  | —  | —    | —    | —    | —                | ÷   | —  | —  | I              | —     | I      | U             | — | R | — | — | 1B     | CTRL          | μ                     | 1 - 2             | 99 if fault taken |
| <b>faultge</b>  | Fault If Greater Or Equal   | —                   | —  | —  | —    | —    | —    | —                | ÷   | —  | —  | I              | —     | I      | U             | — | R | — | — | 1C     | CTRL          | μ                     | 1 - 2             | 99 if fault taken |
|                 | if (( AC.cc and 011) ≠ 0)<br>Constraint Range fault   | —                   | —  | —  | —    | —    | —    | —                | ÷   | —  | —  | I              | —     | I      | U             | — | R | — | — | 1E     | CTRL          | μ                     | 1 - 2             | 99 if fault taken |
| <b>faultl</b>   | Fault If Less   | —                   | —  | —  | —    | —    | —    | —                | ÷   | —  | —  | I              | —     | I      | U             | — | R | — | — | 1D     | CTRL          | μ                     | 1 - 2             | 99 if fault taken |
|                 | if (( AC.cc and 100) ≠ 0)<br>Constraint Range fault   | —                   | —  | —  | —    | —    | —    | —                | ÷   | —  | —  | I              | —     | I      | U             | — | R | — | — | 1F     | CTRL          | μ                     | 1 - 2             | 99 if fault taken |
| <b>faultle</b>  | Fault If Less Or Equal  | —                   | —  | —  | —    | —    | —    | —                | ÷   | —  | —  | I              | —     | I      | U             | — | R | — | — | 18     | CTRL          | μ                     | 1 - 2             | 99 if fault taken |
|                 | if (( AC.cc and 110) ≠ 0)<br>Constraint Range fault   | —                   | —  | —  | —    | —    | —    | —                | ÷   | —  | —  | I              | —     | I      | U             | — | R | — | — | 66:D   | REG           | μ                     | 24 * # frames     | 24 * # frames     |
| <b>faultne</b>  | Fault If Not Equal  | —                   | —  | —  | —    | —    | —    | —                | ÷   | —  | —  | I              | —     | I      | U             | — | R | — | — | 66:C   | REG           | μ                     |                   |                   |
|                 | if (( AC.cc and 101) ≠ 0)<br>Constraint Range fault   | —                   | —  | —  | —    | —    | —    | —                | ÷   | —  | —  | I              | —     | I      | U             | — | R | — | — | 90     | MEM           | M or μ                | 1 + efa           | 1 + efa + bus     |
| <b>faultno</b>  | Fault If Not Ordered  | —                   | —  | —  | —    | —    | —    | —                | ÷   | —  | —  | I              | —     | I      | U             | — | R | — | — | 8C     | MEM           | M or μ                | 0.5 - 1 + efa     | 1 + efa           |
|                 | if ( AC.cc = 000)<br>Constraint Range fault   | —                   | —  | —  | —    | —    | —    | —                | ÷   | —  | —  | I              | —     | I      | U             | — | R | — | — | C0     | MEM           | M or μ                | 1 + efa           | 1 + efa + bus     |
| <b>faulto</b>   | Fault If Ordered  | —                   | —  | —  | —    | —    | —    | —                | ÷   | —  | —  | I              | —     | I      | U             | — | R | — | — | C8     | MEM           | M or μ                | 1 + efa           | 1 + efa + bus     |
|                 | if (( AC.cc and 111) ≠ 0)<br>Constraint Range fault   | —                   | —  | —  | —    | —    | —    | —                | ÷   | —  | —  | I              | —     | I      | U             | — | R | — | — |        |               |                       |                   |                   |
| <b>flushreg</b> | Flush Local Registers   | —                   | —  | —  | —    | —    | —    | —                | ÷   | —  | —  | I              | —     | I      | U             | — | — | — | M | 66:D   | REG           | μ                     | 24 * # frames     | 24 * # frames     |
|                 | Write all cached local register sets to memory<br>Invalidate all local register cache locations | —                   | —  | —  | —    | —    | —    | —                | ÷   | —  | —  | I              | —     | I      | U             | — | — | — | — | 66:C   | REG           | μ                     |                   |                   |
| <b>fmark</b>    | Force Mark  | —                   | —  | —  | —    | —    | —    | —                | ÷   | —  | —  | IBR            | —     | IBR    | —             | — | — | — | — | 66:C   | REG           | μ                     |                   |                   |
|                 | if (PC.te = 1)<br>{ PC.tfp ← 1; TC.bte ← 1;<br>Trace Breakpoint fault }                         | —                   | —  | —  | —    | —    | —    | —                | ÷   | —  | —  | IBR            | —     | IBR    | —             | — | — | — | — | 66:C   | REG           | μ                     |                   |                   |
| <b>ld</b>       | Load<br><i>src, mem dst reg</i>   | —                   | —  | —  | —    | —    | —    | —                | ÷   | —  | —  | I              | —     | I      | OP<br>U<br>OC | — | — | — | — | 90     | MEM           | M or μ                | 1 + efa           | 1 + efa + bus     |
|                 | <i>dst ← memory_word(src)</i>   | —                   | —  | —  | —    | —    | —    | —                | ÷   | —  | —  | I              | —     | I      | OP<br>OC      | — | — | — | — | 8C     | MEM           | M or μ                | 0.5 - 1 + efa     | 1 + efa           |
| <b>lda</b>      | Load Address<br><i>src, mem efa dst reg</i>   | —                   | —  | —  | —    | —    | —    | —                | ÷   | —  | —  | I              | —     | I      | OP<br>OC      | — | — | — | — | C0     | MEM           | M or μ                | 1 + efa           | 1 + efa + bus     |
|                 | <i>dst ← efa(src)</i>   | —                   | —  | —  | —    | —    | —    | —                | ÷   | —  | —  | I              | —     | I      | OP<br>OC      | — | — | — | — | C8     | MEM           | M or μ                | 1 + efa           | 1 + efa + bus     |
| <b>ldib</b>     | Load Integer Byte<br><i>src, mem dst reg</i>  | —                   | —  | —  | —    | —    | —    | —                | ÷   | —  | —  | I              | —     | I      | OP<br>U<br>OC | — | — | — | — | C0     | MEM           | M or μ                | 1 + efa           | 1 + efa + bus     |
|                 | <i>dst ← memory_byte(src) sign-extended</i>   | —                   | —  | —  | —    | —    | —    | —                | ÷   | —  | —  | I              | —     | I      | OP<br>U<br>OC | — | — | — | — | C8     | MEM           | M or μ                | 1 + efa           | 1 + efa + bus     |
| <b>ldis</b>     | Load Integer Short<br><i>src, mem dst reg</i>   | —                   | —  | —  | —    | —    | —    | —                | ÷   | —  | —  | I              | —     | I      | OP<br>U<br>OC | — | — | — | — | C8     | MEM           | M or μ                | 1 + efa           | 1 + efa + bus     |
|                 | <i>dst ← memory_short(src) sign-extended</i>  | —                   | —  | —  | —    | —    | —    | —                | ÷   | —  | —  | I              | —     | I      | OP<br>U<br>OC | — | — | — | — | C8     | MEM           | M or μ                | 1 + efa           | 1 + efa + bus     |

i960<sup>®</sup> Cx Microprocessor User's Guide — Instruction Set Quick Reference

| Mnemonic      | Description  | Arithmetic Controls |    |    |      |      |      | Process Controls |     |    |    | Trace Controls |       | Faults |               |          |   |   |   | Opcode | Opcode Format | Instruction Execution |                   |                |
|---------------|--|---------------------|----|----|------|------|------|------------------|-----|----|----|----------------|-------|--------|---------------|----------|---|---|---|--------|---------------|-----------------------|-------------------|----------------|
|               |  | nif                 | om | of | cc 2 | cc 1 | cc 0 | p                | tfp | em | te | Events         | Modes | T      | O             | A        | C | P | Y |        |               | Mach. Type            | Instruction Issue | Result Latency |
| <b>ldl</b>    | Load Long<br><i>src</i> , mem <i>dst</i> , reg<br><i>dst, dst+1 ← memory_long(src)</i>   | —                   | —  | —  | —    | —    | —    | —                | ÷   | —  | —  | I              | —     | I      | OP<br>U<br>OC | —        | — | — | — | 98     | MEM           | M or μ                | 1 + efa           | 1 + efa + bus  |
| <b>ldob</b>   | Load Ordinal Byte<br><i>src</i> , mem <i>dst</i> , reg<br><i>dst ← memory_byte(src)</i> zero-extended  | —                   | —  | —  | —    | —    | —    | —                | ÷   | —  | —  | I              | —     | I      | OP<br>U<br>OC | —        | — | — | — | 80     | MEM           | M or μ                | 1 + efa           | 1 + efa + bus  |
| <b>ldos</b>   | Load Ordinal Short<br><i>src</i> , mem <i>dst</i> , reg<br><i>dst ← memory_short(src)</i> zero-extended  | —                   | —  | —  | —    | —    | —    | —                | ÷   | —  | —  | I              | —     | I      | OP<br>U<br>OC | —        | — | — | — | 88     | MEM           | M or μ                | 1 + efa           | 1 + efa + bus  |
| <b>ldq</b>    | Load Quad<br><i>src</i> , mem <i>dst</i> , reg<br><i>dst, dst+1, dst+2, dst+3 ← memory_quad(src)</i>   | —                   | —  | —  | —    | —    | —    | —                | ÷   | —  | —  | I              | —     | I      | OP<br>U<br>OC | —        | — | — | — | B0     | MEM           | M or μ                | 1 + efa           | 1 + efa + bus  |
| <b>ldt</b>    | Load Triple<br><i>src</i> , mem <i>dst</i> , reg<br><i>dst, dst+1, dst+2 ← memory_triple(src)</i>  | —                   | —  | —  | —    | —    | —    | —                | ÷   | —  | —  | I              | —     | I      | OP<br>U<br>OC | —        | — | — | — | A0     | MEM           | M or μ                | 1 + efa           | 1 + efa + bus  |
| <b>mark</b>   | Mark<br>if ((PC.te = 1) and (TC.btm = 1))<br>{ PC.tfp ← 1;<br>TC.bte ← 1;<br>Trace Breakpoint fault }  | —                   | —  | —  | —    | —    | —    | —                | ÷   | —  | —  | IBR            | —     | IBR    | U             | —        | — | — | — | 66:B   | REG           | μ                     | 17                | 17             |
| <b>modac</b>  | Modify AC<br><i>mask</i> , reg/lit/sfr <i>src</i> , reg/lit/sfr <i>dst</i> , reg/sfr<br>temp ← AC<br>AC ← ( <i>src</i> and <i>mask</i> ) or (AC and not ( <i>mask</i> ))<br><i>dst ← temp</i>  | ÷                   | ÷  | ÷  | ÷    | ÷    | ÷    | —                | ÷   | —  | —  | I              | —     | I      | U             | —        | — | — | M | 64:5   | REG           | μ                     | 9                 | 9              |
| <b>modi</b>   | Modulo Integer<br><i>src1</i> , reg/lit/sfr <i>src2</i> , reg/lit/sfr <i>dst</i> , reg/sfr<br>if ( <i>src2</i> = 0) Arithmetic Zero Divide fault<br><i>dst ← src2 mod src1</i> /* <i>src2</i> , <i>src1</i> and <i>dst</i> are 32 bits*/   | —                   | —  |    | —    | —    | —    | —                | ÷   | —  | —  | I              | —     | I      | U             | IO<br>ZD | — | — | M | 74:9   | REG           | R                     | 3                 | 36             |
| <b>modify</b> | Modify<br><i>mask</i> , reg/lit/sfr <i>src</i> , reg/lit/sfr <i>src/dst</i> , reg<br><i>src/dst ← (src and mask)</i><br>or ( <i>src/dst</i> and not( <i>mask</i> ))  | —                   | —  | —  | —    | —    | —    | —                | ÷   | —  | —  | I              | —     | I      | U             | —        | — | — | M | 65:0   | REG           | μ                     | 3                 | 3              |
| <b>modpc</b>  | Modify PC<br><i>src</i> , reg/lit/sfr <i>mask</i> , reg/lit/sfr <i>src/dst</i> , reg<br>if (( <i>mask</i> ≠ 0) and (PC.em ≠ Supervisor))<br>Type Mismatch fault<br>temp ← PC<br>PC ← ( <i>mask</i> and <i>src/dst</i> )<br>or (PC and not( <i>mask</i> ))<br><i>src/dst ← temp</i> | —                   | —  | —  | —    | —    | —    | ÷                | ÷   | ÷  | ÷  | I              | —     | I      | U             | —        | — | — | M | 65:5   | REG           | μ                     | 12, 17            | 12, 17         |

i960<sup>®</sup> Cx Microprocessor User's Guide — Instruction Set Quick Reference

| Mnemonic      | Description  | Arithmetic Controls |    |    |      |      |      | Process Controls |     |    |      | Trace Controls |       | Faults |    |   |   |   |      | Opcode | Opcode Format | Instruction Execution |                   |                |
|---------------|--|---------------------|----|----|------|------|------|------------------|-----|----|------|----------------|-------|--------|----|---|---|---|------|--------|---------------|-----------------------|-------------------|----------------|
|               |  | nif                 | om | of | cc 2 | cc 1 | cc 0 | p                | tfp | em | te   | Events         | Modes | T      | O  | A | C | P | Y    |        |               | Mach. Type            | Instruction Issue | Result Latency |
| <b>modtc</b>  | Modify TC<br><i>mask</i> , <i>src</i> , <i>dst</i><br>reg/lit/sfr reg/lit/sfr reg/sfr<br><br>temp ← TC<br>TC ← ( <i>mask</i> and <i>src</i> ) or (TC and not( <i>mask</i> ))<br><i>dst</i> ← temp    | —                   | —  | —  | —    | —    | —    | ÷                | —   | —  | I, √ | ÷              | I     | U      | —  | — | — | M | 65:4 | REG    | μ             | 15                    | 15                |                |
| <b>mov</b>    | Move<br><i>src</i> , <i>dst</i><br>reg/lit/sfr reg/sfr<br><br><i>dst</i> ← <i>src</i> /* 32 bits */  | —                   | —  | —  | —    | —    | —    | ÷                | —   | —  | I    | —              | I     | U      | —  | — | — | M | 5C:C | REG    | R             | 0.5 - 1               | 1                 |                |
| <b>movl</b>   | Move Long<br><i>src</i> , <i>dst</i><br>reg/lit/sfr reg/sfr<br><br><i>dst</i> ← <i>src</i> /* 64 bits */   | —                   | —  | —  | —    | —    | —    | ÷                | —   | —  | I    | —              | I     | U      | —  | — | — | M | 5D:C | REG    | R             | 0.5 - 1               | 1                 |                |
| <b>movq</b>   | Move Quad<br><i>src</i> , <i>dst</i><br>reg/lit/sfr reg/sfr<br><br><i>dst</i> ← <i>src</i> /* 128 bits */  | —                   | —  | —  | —    | —    | —    | ÷                | —   | —  | I    | —              | I     | U      | —  | — | — | M | 5F:C | REG    | μ             | 2                     | 2                 |                |
| <b>movt</b>   | Move Triple<br><i>src</i> , <i>dst</i><br>reg/lit/sfr reg/sfr<br><br><i>dst</i> ← <i>src</i> /* 96 bits */   | —                   | —  | —  | —    | —    | —    | ÷                | —   | —  | I    | —              | I     | U      | —  | — | — | M | 5E:C | REG    | μ             | 2                     | 2                 |                |
| <b>muli</b>   | Multiply Integer<br><i>src1</i> , <i>src2</i> , <i>dst</i><br>reg/lit/sfr reg/lit/sfr reg/sfr<br><br><i>dst</i> ← <i>src2</i> * <i>src1</i> /* <i>dst</i> , <i>src2</i> , <i>src1</i> are 32 bits */ | —                   | —  | !  | —    | —    | —    | ÷                | —   | —  | I    | —              | I     | U      | IO | — | — | M | 74:1 | REG    | R             | 0.5 - 1               | 2, 3, 4, 5        |                |
| <b>mulo</b>   | Multiply Ordinal<br><i>src1</i> , <i>src2</i> , <i>dst</i><br>reg/lit/sfr reg/lit/sfr reg/sfr<br><br><i>dst</i> ← <i>src2</i> * <i>src1</i> /* <i>dst</i> , <i>src2</i> , <i>src1</i> are 32 bits */ | —                   | —  | —  | —    | —    | —    | ÷                | —   | —  | I    | —              | I     | U      | —  | — | — | M | 70:1 | REG    | R             | 0.5 - 1               | 2, 3, 4, 5        |                |
| <b>nand</b>   | Nand<br><i>src1</i> , <i>src2</i> , <i>dst</i><br>reg/lit/sfr reg/lit/sfr reg/sfr<br><br><i>dst</i> ← not( <i>src2</i> and <i>src1</i> )   | —                   | —  | —  | —    | —    | —    | ÷                | —   | —  | I    | —              | I     | U      | —  | — | — | M | 58:E | REG    | R             | 0.5 - 1               | 1                 |                |
| <b>nor</b>    | Nor<br><i>src1</i> , <i>src2</i> , <i>dst</i><br>reg/lit/sfr reg/lit/sfr reg/sfr<br><br><i>dst</i> ← not( <i>src2</i> or <i>src1</i> )   | —                   | —  | —  | —    | —    | —    | ÷                | —   | —  | I    | —              | I     | U      | —  | — | — | M | 58:8 | REG    | R             | 0.5 - 1               | 1                 |                |
| <b>not</b>    | Not<br><i>src</i> , <i>dst</i><br>reg/lit/sfr reg/sfr<br><br><i>dst</i> ← not( <i>src</i> )  | —                   | —  | —  | —    | —    | —    | ÷                | —   | —  | I    | —              | I     | U      | —  | — | — | M | 58:A | REG    | R             | 0.5 - 1               | 1                 |                |
| <b>notand</b> | Not And<br><i>src1</i> , <i>src2</i> , <i>dst</i><br>reg/lit/sfr reg/lit/sfr reg/sfr<br><br><i>dst</i> ← (not( <i>src2</i> )) and <i>src1</i>  | —                   | —  | —  | —    | —    | —    | ÷                | —   | —  | I    | —              | I     | U      | —  | — | — | M | 58:4 | REG    | R             | 0.5 - 1               | 1                 |                |

i960<sup>®</sup> Cx Microprocessor User's Guide — Instruction Set Quick Reference

| Mnemonic      | Description  | Arithmetic Controls |    |    |      |      |      | Process Controls |     |    |         | Trace Controls |         | Faults |       |   |   |    |      | Opcode | Opcode Format | Instruction Execution |                   |                |
|---------------|--|---------------------|----|----|------|------|------|------------------|-----|----|---------|----------------|---------|--------|-------|---|---|----|------|--------|---------------|-----------------------|-------------------|----------------|
|               |  | nif                 | om | of | cc 2 | cc 1 | cc 0 | p                | tfp | em | te      | Events         | Modes   | T      | O     | A | C | P  | Y    |        |               | Mach. Type            | Instruction Issue | Result Latency |
| <b>notbit</b> | Not Bit<br><i>bitpos, src, dst</i><br>reg/lit/sfr reg/lit/sfr reg/sfr<br><i>dst ← src xor 2<sup>n</sup>(bitpos mod 32)</i>   | —                   | —  | —  | —    | —    | —    | ÷                | —   | —  | I       | —              | I       | U      | —     | — | — | M  | 58:0 | REG    | R             | 0.5 - 1               | 1                 |                |
| <b>notor</b>  | Not Or<br><i>src1, src2, dst</i><br>reg/lit/sfr reg/lit/sfr reg/sfr<br><i>dst ← (not (src2)) or src1</i>   | —                   | —  | —  | —    | —    | —    | ÷                | —   | —  | I       | —              | I       | U      | —     | — | — | M  | 58:D | REG    | R             | 0.5 - 1               | 1                 |                |
| <b>or</b>     | Or<br><i>src1, src2, dst</i><br>reg/lit/sfr reg/lit/sfr reg/sfr<br><i>dst ← src2 or src1</i>   | —                   | —  | —  | —    | —    | —    | ÷                | —   | —  | I       | —              | I       | U      | —     | — | — | M  | 58:7 | REG    | R             | 0.5 - 1               | 1                 |                |
| <b>ornot</b>  | Or Not<br><i>src1, src2, dst</i><br>reg/lit/sfr reg/lit/sfr reg/sfr<br><i>dst ← src2 or (not(src1))</i>  | —                   | —  | —  | —    | —    | —    | ÷                | —   | —  | I       | —              | I       | U      | —     | — | — | M  | 58:B | REG    | R             | 0.5 - 1               | 1                 |                |
| <b>remi</b>   | Remainder Integer<br><i>src1, src2, dst</i><br>reg/lit/sfr reg/lit/sfr reg/sfr<br>if ( <i>src1</i> = 0) Arithmetic Zero Divide fault<br><i>dst ← remainder (src2/src1)</i><br>/* <i>src2, src1</i> and <i>dst</i> are 32 bits*/  | —                   | —  | !  | —    | —    | —    | ÷                | —   | —  | I       | —              | I       | U      | IO ZD | — | — | M  | 74:8 | REG    | m             | 3                     | 36                |                |
| <b>remo</b>   | Remainder Ordinal<br><i>src1, src2, dst</i><br>reg/lit/sfr reg/lit/sfr reg/sfr<br>if ( <i>src1</i> = 0) Arithmetic Zero Divide fault<br><i>dst ← remainder (src2 * src1)</i><br>/* <i>src2, src1</i> and <i>dst</i> are 32 bits*/  | —                   | —  | —  | —    | —    | —    | ÷                | —   | —  | I       | —              | I       | U      | ZD    | — | — | M  | 70:8 | REG    | m             | 3                     | 36                |                |
| <b>ret</b>    | Return<br>if ((PPF.rt = 001) or (PPF.rt = 111))<br>{ /* ret from fault or interrupt handler */<br>AC ← memory (FP -12)<br>if (PC.em = Supervisor)<br>PC ← memory(FP-16)<br>}<br>else if ((PPF.rt = 010) or (PPF.rt = 011))<br>{ /* ret to user procedure*/<br>PC.te ← PFP.r0<br>PC.em ← User<br>}<br>FP ← PFP<br>r0-15 ← memory (FP) /* accesses are cached in*/<br>IP ← RIP /*local register cache */ | ÷                   | ÷  | ÷  | ÷    | ÷    | ÷    | ÷                | ∅   | ÷  | I R P S | —              | I R P S | U      | —     | — | — | 0A | CTRL | μ      | 4 + fill      | 4 + fill              |                   |                |
| <b>rotate</b> | Rotate<br><i>len, src, dst</i><br>reg/lit/sfr reg/lit/sfr reg/sfr<br><i>dst ← src rotate_left (len mod 32)</i>   | —                   | —  | —  | —    | —    | —    | ÷                | —   | —  | I       | —              | I       | U      | —     | — | — | M  | 59:D | REG    | R             | 0.5 - 1               | 1                 |                |

i960<sup>®</sup> Cx Microprocessor User's Guide — Instruction Set Quick Reference

| Mnemonic        | Description   | Arithmetic Controls |    |    |      |      |      | Process Controls |     |    |    | Trace Controls |       | Faults |    |   |   |   |      | Opcode | Opcode Format | Instruction Execution                    |  |                |
|-----------------|---|---------------------|----|----|------|------|------|------------------|-----|----|----|----------------|-------|--------|----|---|---|---|------|--------|---------------|--|--|----------------|
|                 |   | nif                 | om | of | cc 2 | cc 1 | cc 0 | p                | tfp | em | te | Events         | Modes | T      | O  | A | C | P | Y    |        |               | Mach. Type                               | Instruction Issue                        | Result Latency |
| <b>scanbit</b>  | Scan for Bit<br><i>src</i> ,<br>reg/lit/sfr<br><i>dst</i><br>reg/sfr<br><br>if( <i>src</i> = 0)<br>{<br><i>dst</i> ← 0xffff ffff<br>AC.cc ← 000<br>}<br>else<br>{<br>for (i = 31; ( <i>src</i> and 2 <sup>i</sup> ) = 0; i ← i-1)<br><i>dst</i> ← i;<br>AC.cc ← 010<br>}<br>}   | —                   | —  | —  | 0    | ÷    | 0    | —                | ÷   | —  | —  | I              | —     | I      | U  | — | — | — | M    | 64:1   | REG           | μ  | 1  | 1              |
| <b>scanbyte</b> | Scan Byte Equal<br><i>src1</i> ,<br>reg/lit/sfr<br><i>src2</i> ,<br>reg/lit/sfr<br><br>if (<br>(( <i>src1</i> and 0x0000 00ff) =<br>( <i>src2</i> and 0x0000 00ff)) or<br>(( <i>src1</i> and 0x0000 f000) =<br>( <i>src2</i> and 0x0000 f000)) or<br>(( <i>src1</i> and 0x00ff 0000) =<br>( <i>src2</i> and 0x00ff 0000)) or<br>(( <i>src1</i> and 0xff00 0000) =<br>( <i>src2</i> and 0xff00 0000))<br>)<br>AC.cc ← 010<br>else<br>AC.cc ← 000 | —                   | —  | —  | 0    | ÷    | 0    | —                | ÷   | —  | —  | I              | —     | I      | U  | — | — | — | M    | 5A:C   | REG           | R  | 0.5 - 1                                  | 1              |
| <b>sdma</b>     | Setup DMA Channel<br><i>src1</i> ,<br>reg/lit/sfr<br><i>src2</i> ,<br>reg/lit/sfr<br><i>src3</i> ,<br>reg/lit<br><br>dma_channel_control ( <i>src1</i> ) ← <i>src2</i><br>if (not chaining mode)<br>DMA_RAM ( <i>src1</i> ) ← <i>src3</i> /* quad store */<br>else<br>DMA_RAM ( <i>src1</i> ) ← <i>src3</i> /* word store */  | —                   | —  | —  | —    | —    | —    | ÷                | —   | —  | I  | —              | I     | U      | —  | P | — | M | 63:0 | REG    | μ             | 22, 40 for<br>back-to-<br>back<br>SDMA's | 22, 40 for<br>back-to-<br>back<br>SDMA's |                |
| <b>setbit</b>   | Set Bit<br><i>bitpos</i> ,<br>reg/lit/sfr<br><i>src</i> ,<br>reg/lit/sfr<br><i>dst</i><br>reg/sfr<br><br><i>dst</i> ← <i>src</i> or 2 <sup>(<i>bitpos</i> mod 32)</sup>   | —                   | —  | —  | —    | —    | —    | ÷                | —   | —  | I  | —              | I     | U      | —  | — | — | M | 58:3 | REG    | R             | 0.5 - 1                                  | 1  |                |
| <b>shli</b>     | Shift Left Integer<br><i>len</i> ,<br>reg/lit/sfr<br><i>src</i> ,<br>reg/lit/sfr<br><i>dst</i><br>reg/sfr<br><br>if (len > 32) i ← 32<br>else i ← len<br>temp ← <i>src</i><br>s_sign ← temp.bit31<br>while ((temp.bit31 = s_sign) and (i ≠ 0))<br>{<br>temp ← temp << 1<br>i--<br>}<br><i>dst</i> ← temp  | —                   | —  | 1  | —    | —    | —    | ÷                | —   | —  | I  | —              | I     | U      | IO | — | — | M | 59:E | REG    | R             | 0.5 - 1                                  | 1  |                |



i960<sup>®</sup> Cx Microprocessor User's Guide — Instruction Set Quick Reference

| Mnemonic       | Description  | Arithmetic Controls |    |    |      |      |      | Process Controls |     |    |    | Trace Controls |       | Faults |   |   |   |   |      | Opcode | Opcode Format | Instruction Execution |                   |                |
|----------------|--|---------------------|----|----|------|------|------|------------------|-----|----|----|----------------|-------|--------|---|---|---|---|------|--------|---------------|-----------------------|-------------------|----------------|
|                |  | nif                 | om | of | cc 2 | cc 1 | cc 0 | p                | tfp | em | te | Events         | Modes | T      | O | A | C | P | Y    |        |               | Mach. Type            | Instruction Issue | Result Latency |
| <b>shlo</b>    | Shift Left Ordinal<br><i>len</i> , <i>src</i> , <i>dst</i><br>reg/lit/sfr reg/lit/sfr reg/sfr<br>if (len < 32) <i>dst</i> ← <i>src</i> << len<br>else <i>dst</i> ← 0   | —                   | —  | —  | —    | —    | —    | ÷                | —   | —  | I  | —              | I     | U      | — | — | — | M | 59:C | REG    | R             | 0.5 - 1               | 1                 |                |
| <b>shrdi</b>   | Shift Right Dividing Integer<br><i>len</i> , <i>src</i> , <i>dst</i><br>reg/lit/sfr reg/lit/sfr reg/sfr<br>if (len > 32) <i>i</i> ← 32;<br>else <i>i</i> ← len;<br>temp ← <i>src</i> ;<br>s_sign ← temp.bit31<br>lost_bit ← 0<br>while (i ≠ 0)<br>{<br>lost_bit ← lost_bit or temp.bit0;<br>temp ← temp >> 1;<br>temp.bit31 ← temp.bit30;<br>i ← i - 1;<br>}<br>if ((s_sign = 1) and (lost_bit = 1))<br>temp ← temp + 1;<br><i>dst</i> ← temp; | —                   | —  | —  | —    | —    | —    | ÷                | —   | —  | I  | —              | I     | U      | — | — | — | M | 59:A | REG    | m             | 3                     | 3                 |                |
| <b>shri</b>    | Shift Right Integer<br><i>len</i> , <i>src</i> , <i>dst</i><br>reg/lit/sfr reg/lit/sfr reg/sfr<br>if (len > 32) <i>i</i> ← 32;<br>else <i>i</i> ← len;<br>temp ← <i>src</i> ;<br>while ((temp.31 = temp.30) and (i ≠ 0))<br>{<br>temp ← temp >> 1;<br>temp.bit31 ← temp.bit30;<br>i ← i - 1;<br>}<br><i>dst</i> ← temp;  | —                   | —  | —  | —    | —    | —    | ÷                | —   | —  | I  | —              | I     | U      | — | — | — | M | 59:B | REG    | R             | 0.5 - 1               | 1                 |                |
| <b>shro</b>    | Shift Right Ordinal<br><i>len</i> , <i>src</i> , <i>dst</i><br>reg/lit/sfr reg/lit/sfr reg/sfr<br>if (len < 32) <i>dst</i> ← <i>src</i> >> len<br>else <i>dst</i> ← 0  | —                   | —  | —  | —    | —    | —    | ÷                | —   | —  | I  | —              | I     | U      | — | — | — | M | 59:8 | REG    | R             | 0.5 - 1               | 1                 |                |
| <b>spanbit</b> | Span Over Bit<br><i>src</i> , <i>dst</i><br>reg/lit/sfr reg/sfr<br>if( <i>src</i> = 0xffff ffff)<br>{<br><i>dst</i> ← 0xffff ffff<br>AC.cc ← 000<br>}<br>else<br>{<br>for (i =31; ( <i>src</i> and 2 <sup>i</sup> ) ≠ 0; i ← i - 1);<br><i>dst</i> ← i<br>AC.cc ← 010<br>}   | —                   | —  | —  | 0    | ÷    | 0    | —                | ÷   | —  | —  | I              | —     | I      | U | — | — | — | M    | 64:0   | REG           | μ                     | 2                 | 2              |

i960<sup>®</sup> Cx Microprocessor User's Guide — Instruction Set Quick Reference

| Mnemonic    | Description   | Arithmetic Controls |    |    |      |      |      | Process Controls |     |    |    | Trace Controls |       | Faults        |               |   |   |   |      | Opcode | Opcode Format | Instruction Execution |                   |                |
|-------------|---|---------------------|----|----|------|------|------|------------------|-----|----|----|----------------|-------|---------------|---------------|---|---|---|------|--------|---------------|-----------------------|-------------------|----------------|
|             |   | nif                 | om | of | cc 2 | cc 1 | cc 0 | p                | tfp | em | te | Events         | Modes | T             | O             | A | C | P | Y    |        |               | Mach. Type            | Instruction Issue | Result Latency |
| <b>st</b>   | Store<br><i>src</i> ,<br>reg/lit <i>dst</i><br>mem<br>memory_word( <i>dst</i> ) ← <i>src</i>  | —                   | —  | —  | —    | —    | —    | —                | ÷   | —  | —  | I              | —     | I             | OP<br>U<br>OC | — | — | — | M    | 92     | MEM           | M or μ                | 0.5 - 1 +<br>efa  |                |
| <b>stib</b> | Store Integer Byte<br><i>src</i> ,<br>reg/lit <i>dst</i><br>mem<br>memory_byte( <i>dst</i> ) ← <i>src</i> /* truncated to 8 bits */   | —                   | —  | !  | —    | —    | —    | ÷                | —   | —  | I  | —              | I     | OP<br>U<br>OC | IO            | — | — | M | C2   | MEM    | M or μ        | 0.5 - 1 +<br>efa      |                   |                |
| <b>stis</b> | Store Integer Short<br><i>src</i> ,<br>reg/lit <i>dst</i><br>mem<br>memory_short( <i>dst</i> ) ← <i>src</i> /* truncated to 16 bits */  | —                   | —  | !  | —    | —    | —    | ÷                | —   | —  | I  | —              | I     | OP<br>U<br>OC | IO            | — | — | M | CA   | MEM    | M or μ        | 0.5 - 1 +<br>efa      |                   |                |
| <b>stl</b>  | Store Long<br><i>src</i> ,<br>reg/lit <i>dst</i><br>mem<br>memory_long( <i>dst</i> ) ← <i>src</i> , <i>src</i> +1   | —                   | —  | —  | —    | —    | —    | ÷                | —   | —  | I  | —              | I     | OP<br>U<br>OC | —             | — | — | M | 9A   | MEM    | M or μ        | 0.5 - 1 +<br>efa      |                   |                |
| <b>stob</b> | Store Ordinal Byte<br><i>src</i> ,<br>reg/lit <i>dst</i><br>mem<br>memory_byte( <i>dst</i> ) ← <i>src</i> /*truncated to 8 bits */  | —                   | —  | —  | —    | —    | —    | ÷                | —   | —  | I  | —              | I     | OP<br>U<br>OC | —             | — | — | M | 82   | MEM    | M or μ        | 0.5 - 1 +<br>efa      |                   |                |
| <b>stos</b> | Store Ordinal Short<br><i>src</i> ,<br>reg/lit <i>dst</i><br>mem<br>memory_short( <i>dst</i> ) ← <i>src</i> /* truncated to 16 bits */  | —                   | —  | —  | —    | —    | —    | ÷                | —   | —  | I  | —              | I     | OP<br>U<br>OC | —             | — | — | M | 8A   | MEM    | M or μ        | 0.5 - 1 +<br>efa      |                   |                |
| <b>stq</b>  | Store Quad<br><i>src</i> ,<br>reg/lit <i>dst</i><br>mem<br>memory_quad( <i>dst</i> ) ← <i>src</i> , <i>src</i> +1, <i>src</i> +2, <i>src</i> +3   | —                   | —  | —  | —    | —    | —    | ÷                | —   | —  | I  | —              | I     | OP<br>U<br>OC | —             | — | — | M | B2   | MEM    | M or μ        | 0.5 - 1 +<br>efa      |                   |                |
| <b>stt</b>  | Store Triple<br><i>src</i> ,<br>reg/lit <i>dst</i><br>mem<br>memory_triple( <i>dst</i> ) ← <i>src</i> , <i>src</i> +1, <i>src</i> +2  | —                   | —  | —  | —    | —    | —    | ÷                | —   | —  | I  | —              | I     | OP<br>U<br>OC | —             | — | — | M | A2   | MEM    | M or μ        | 0.5 - 1 +<br>efa      |                   |                |
| <b>subc</b> | Subtract Ordinal With Carry<br><i>src1</i> ,<br>reg/lit/sfr <i>src2</i> ,<br>reg/lit/sfr <i>dst</i><br>reg/sfr<br><i>dst</i> ← <i>src2</i> - <i>src1</i> - not(AC.cc1)<br>AC.cc0 ← integer overflow<br>AC.cc1 ← carry out | —                   | —  | —  | 0    | ÷    | ÷    | —                | ÷   | —  | I  | —              | I     | U             | —             | — | — | M | 5B:2 | REG    | R             | 0.5 - 1               | 1                 |                |
| <b>subi</b> | Subtract Integer<br><i>src1</i> ,<br>reg/lit/sfr <i>src2</i> ,<br>reg/lit/sfr <i>dst</i><br>reg/sfr<br><i>dst</i> ← <i>src2</i> - <i>src1</i>   | —                   | —  | !  | —    | —    | —    | ÷                | —   | —  | I  | —              | I     | U             | IO            | — | — | M | 59:3 | REG    | R             | 0.5 - 1               | 1                 |                |
| <b>subo</b> | Subtract Ordinal<br><i>src1</i> ,<br>reg/lit/sfr <i>src2</i> ,<br>reg/lit/sfr <i>dst</i><br>reg/sfr<br><i>dst</i> ← <i>src2</i> - <i>src1</i>   | —                   | —  | —  | —    | —    | —    | ÷                | —   | —  | I  | —              | I     | U             | —             | — | — | M | 59:2 | REG    | R             | 0.5 - 1               | 1                 |                |

i960<sup>®</sup> Cx Microprocessor User's Guide — Instruction Set Quick Reference

| Mnemonic  | Description  | Arithmetic Controls |    |    |      |      |      | Process Controls |     |    |    | Trace Controls |       | Faults |   |   |   |   |   | Opcode | Opcode Format | Instruction Execution |                   |                |  |
|---|--|---------------------|----|----|------|------|------|------------------|-----|----|----|----------------|-------|--------|---|---|---|---|---|--------|---------------|-----------------------|-------------------|----------------|--|
|   |  | nif                 | om | of | cc 2 | cc 1 | cc 0 | p                | tfp | em | te | Events         | Modes | T      | O | A | C | P | Y |        |               | Mach. Type            | Instruction Issue | Result Latency |  |
| <b>syncf</b>                                    | Synchronize Faults<br>if (AC.nif ≠ 1)<br>{<br>Wait until no imprecise fault could occur associated with instructions which have begun, but are not completed.<br>} | —                   | —  | —  | —    | —    | —    | —                | ÷   | —  | —  | I              | —     | I      | U | — | — | — | — | 66:F   | REG           | μ                     | 4                 | 4              |  |
| <b>sysctl</b><br><b>80960CA</b>                 | System Control<br><i>src1</i> , <i>src2</i> , <i>src3</i><br>reg/lit/sfr reg/lit/sfr reg/lit<br><i>i</i> ← ( <i>src1</i> and 0xf) >> 8<br>switch ( <i>i</i> )      |                     |    |    |      |      |      |                  |     |    |    |                |       |        |   |   |   |   |   | 65:9   | REG           | μ                     |                   |                |  |
|   | case 0: Post an Interrupt<br>break;  | —                   | —  | —  | —    | —    | —    | —                | ÷   | —  | —  | I              | —     | I      | U | — | — | — | M |        |               |                       | 37 + bus          | 37 + bus       |  |
|   | case 1: Purge the Instruction Cache<br>break;  | —                   | —  | —  | —    | —    | —    | —                | ÷   | —  | —  | I              | —     | I      | U | — | — | — | M |        |               |                       | 38                | 38             |  |
|   | case 2: Configure the Instruction Cache  |                     |    |    |      |      |      |                  |     |    |    |                |       |        |   |   |   |   |   |        |               |                       |                   |                |  |
|   | 1 Kbyte cache enabled  | —                   | —  | —  | —    | —    | —    | —                | ÷   | —  | —  | I              | —     | I      | U | — | — | — | M |        |               |                       | 52                | 52             |  |
|   | 1 Kbyte cache disabled   |                     |    |    |      |      |      |                  |     |    |    |                |       |        |   |   |   |   |   |        |               |                       | 48                | 48             |  |
|   | load and lock 1 Kbyte  |                     |    |    |      |      |      |                  |     |    |    |                |       |        |   |   |   |   |   |        |               |                       | 2078 + bus        | 2078 + bus     |  |
|   | load and lock 512 bytes  |                     |    |    |      |      |      |                  |     |    |    |                |       |        |   |   |   |   |   |        |               |                       | 1103 + bus        | 1103 + bus     |  |
|   | break;   |                     |    |    |      |      |      |                  |     |    |    |                |       |        |   |   |   |   |   |        |               |                       |                   |                |  |
|   | case 3: Software Reset<br>break;   | 0                   | 0  | 0  | 0    | 0    | 0    | 31               | ÷   | 1  | 0  | I              | 0     | I      | U | — | — | — | M |        |               |                       | 243 + bus         | 243 + bus      |  |
| case 4: Load Control Register Group<br>break;   | —  | —                   | —  | —  | —    | —    | —    | ÷                | —   | —  | I  | —              | I     | U      | — | — | — | M |   |        |               | 42 + bus              | 42 + bus          |                |  |
| default: Operation Invalid Operand fault return | ?  | ?                   | ?  | ?  | ?    | ?    | ?    | ?                | ?   | ?  | ?  | ?              | ?     | ?      | ? | ? | ? | ? |   |        |               | ?                     | ?                 |                |  |
| <b>sysctl</b><br><b>80960CF</b>                 | System Control<br><i>src1</i> , <i>src2</i> , <i>src3</i><br>reg/lit/sfr reg/lit/sfr reg/lit<br><i>i</i> ← ( <i>src1</i> and 0xf) >> 8<br>switch ( <i>i</i> )      |                     |    |    |      |      |      |                  |     |    |    |                |       |        |   |   |   |   |   | 65:9   | REG           | μ                     |                   |                |  |
|   | case 0: Post an Interrupt<br>break;  | —                   | —  | —  | —    | —    | —    | —                | ÷   | —  | —  | I              | —     | I      | U | — | — | — | M |        |               |                       | 37 + bus          | 37 + bus       |  |
|   | case 1: Purge the Instruction Cache<br>break;  | —                   | —  | —  | —    | —    | —    | —                | ÷   | —  | —  | I              | —     | I      | U | — | — | — | M |        |               |                       | 38                | 38             |  |
|   | case 2: Configure the Instruction Cache  |                     |    |    |      |      |      |                  |     |    |    |                |       |        |   |   |   |   |   |        |               |                       |                   |                |  |
|   | 4 Kbyte cache enabled  | —                   | —  | —  | —    | —    | —    | —                | ÷   | —  | —  | I              | —     | I      | U | — | — | — | M |        |               |                       | 52                | 52             |  |
|   | 4 Kbyte cache disabled   |                     |    |    |      |      |      |                  |     |    |    |                |       |        |   |   |   |   |   |        |               |                       | 48                | 48             |  |
|   | load and lock 2 Kbytes   |                     |    |    |      |      |      |                  |     |    |    |                |       |        |   |   |   |   |   |        |               |                       |                   |                |  |
|   | break;   |                     |    |    |      |      |      |                  |     |    |    |                |       |        |   |   |   |   |   |        |               |                       | 3653 + bus        | 3653 + bus     |  |
|   | case 3: Software Reset<br>break;   | 0                   | 0  | 0  | 0    | 0    | 0    | 31               | ÷   | 1  | 0  | I              | 0     | I      | U | — | — | — | M |        |               |                       | 265 + bus         | 265 + bus      |  |
|   | case 4: Load Control Register Group<br>break;  | —                   | —  | —  | —    | —    | —    | —                | ÷   | —  | —  | I              | —     | I      | U | — | — | — | M |        |               |                       | 42 + bus          | 42 + bus       |  |
| default: Operation Invalid Operand fault return | ?  | ?                   | ?  | ?  | ?    | ?    | ?    | ?                | ?   | ?  | ?  | ?              | ?     | ?      | ? | ? | ? | ? |   |        |               | ?                     | ?                 |                |  |

i960<sup>®</sup> Cx Microprocessor User's Guide — Instruction Set Quick Reference

| Mnemonic      | Description  | Arithmetic Controls |    |    |      |      |      | Process Controls |     |    |    | Trace Controls |       | Faults |   |   |   |   |   | Opcode | Opcode Format | Instruction Execution |                   |                |
|---------------|--|---------------------|----|----|------|------|------|------------------|-----|----|----|----------------|-------|--------|---|---|---|---|---|--------|---------------|-----------------------|-------------------|----------------|
|               |  | nif                 | om | of | cc 2 | cc 1 | cc 0 | p                | tfp | em | te | Events         | Modes | T      | O | A | C | P | Y |        |               | Mach. Type            | Instruction Issue | Result Latency |
| <b>teste</b>  | Test For Equal<br><i>dst</i><br>reg/sfr<br>if (( AC.cc and 010) ≠ 0) <i>dst</i> ← 1<br>else <i>dst</i> ← 0   | —                   | —  | —  | —    | —    | —    | —                | ÷   | —  | —  | I              | —     | I      | U | — | — | — | M | 22     | COBR          | μ                     | 1 - 2             | 1 - 2          |
| <b>testg</b>  | Test For Greater<br><i>dst</i><br>reg/sfr<br>if (( AC.cc and 001) ≠ 0) <i>dst</i> ← 1<br>else <i>dst</i> ← 0   | —                   | —  | —  | —    | —    | —    | —                | ÷   | —  | —  | I              | —     | I      | U | — | — | — | M | 21     | COBR          | μ                     | 1 - 2             | 1 - 2          |
| <b>testge</b> | Test For Greater Or Equal<br><i>dst</i><br>reg/sfr<br>if (( AC.cc and 011) ≠ 0) <i>dst</i> ← 1<br>else <i>dst</i> ← 0  | —                   | —  | —  | —    | —    | —    | —                | ÷   | —  | —  | I              | —     | I      | U | — | — | — | M | 23     | COBR          | μ                     | 1 - 2             | 1 - 2          |
| <b>testl</b>  | Test For Less<br><i>dst</i><br>reg/sfr<br>if (( AC.cc and 100) ≠ 0) <i>dst</i> ← 1<br>else <i>dst</i> ← 0  | —                   | —  | —  | —    | —    | —    | —                | ÷   | —  | —  | I              | —     | I      | U | — | — | — | M | 24     | COBR          | μ                     | 1 - 2             | 1 - 2          |
| <b>testle</b> | Test For Less Or Equal<br><i>dst</i><br>reg/sfr<br>if (( AC.cc and 110) ≠ 0) <i>dst</i> ← 1<br>else <i>dst</i> ← 0   | —                   | —  | —  | —    | —    | —    | —                | ÷   | —  | —  | I              | —     | I      | U | — | — | — | M | 26     | COBR          | μ                     | 1 - 2             | 1 - 2          |
| <b>testne</b> | Test For Not Equal<br><i>dst</i><br>reg/sfr<br>if (( AC.cc and 101) ≠ 0) <i>dst</i> ← 1<br>else <i>dst</i> ← 0   | —                   | —  | —  | —    | —    | —    | —                | ÷   | —  | —  | I              | —     | I      | U | — | — | — | M | 25     | COBR          | μ                     | 1 - 2             | 1 - 2          |
| <b>testno</b> | Test For Not Ordered<br><i>dst</i><br>reg/sfr<br>if (AC.cc = 000) <i>dst</i> ← 1<br>else <i>dst</i> ← 0  | —                   | —  | —  | —    | —    | —    | —                | ÷   | —  | —  | I              | —     | I      | U | — | — | — | M | 20     | COBR          | μ                     | 1 - 2             | 1 - 2          |
| <b>testo</b>  | Test For Ordered<br><i>dst</i><br>reg/sfr<br>if (( AC.cc and 111) ≠ 0) <i>dst</i> ← 1<br>else <i>dst</i> ← 0   | —                   | —  | —  | —    | —    | —    | —                | ÷   | —  | —  | I              | —     | I      | U | — | — | — | M | 27     | COBR          | μ                     | 1 - 2             | 1 - 2          |
| <b>udma</b>   | Update DMA Channel<br>Copy DMA working registers to on-chip DMA RAM  | —                   | —  | —  | —    | —    | —    | —                | ÷   | —  | —  | I              | —     | I      | U | — | P | — | — | 63:1   | REG           | μ                     | 4                 | 4              |
| <b>xnor</b>   | Exclusive Nor<br><i>src1</i> , <i>src2</i> , <i>dst</i><br>reg/lit/sfr reg/lit/sfr reg/sfr<br><i>dst</i> ← not( <i>src2</i> or <i>src1</i> ) or ( <i>src2</i> and <i>src1</i> )  | —                   | —  | —  | —    | —    | —    | —                | ÷   | —  | —  | I              | —     | I      | U | — | — | — | M | 58:9   | REG           | R                     | 0.5 - 1           | 1              |
| <b>xor</b>    | Exclusive Or<br><i>src1</i> , <i>src2</i> , <i>dst</i><br>reg/lit/sfr reg/lit/sfr reg/sfr<br><i>dst</i> ← ( <i>src2</i> or <i>src1</i> ) and not ( <i>src2</i> and <i>src1</i> ) | —                   | —  | —  | —    | —    | —    | —                | ÷   | —  | —  | I              | —     | I      | U | — | — | — | M | 58:6   | REG           | R                     | 0.5 - 1           | 1              |